

# Huntington Square III

3350 SW 148<sup>th</sup> Ave  
Miramar, FL 33027

Suite 123 | 3,492 SF

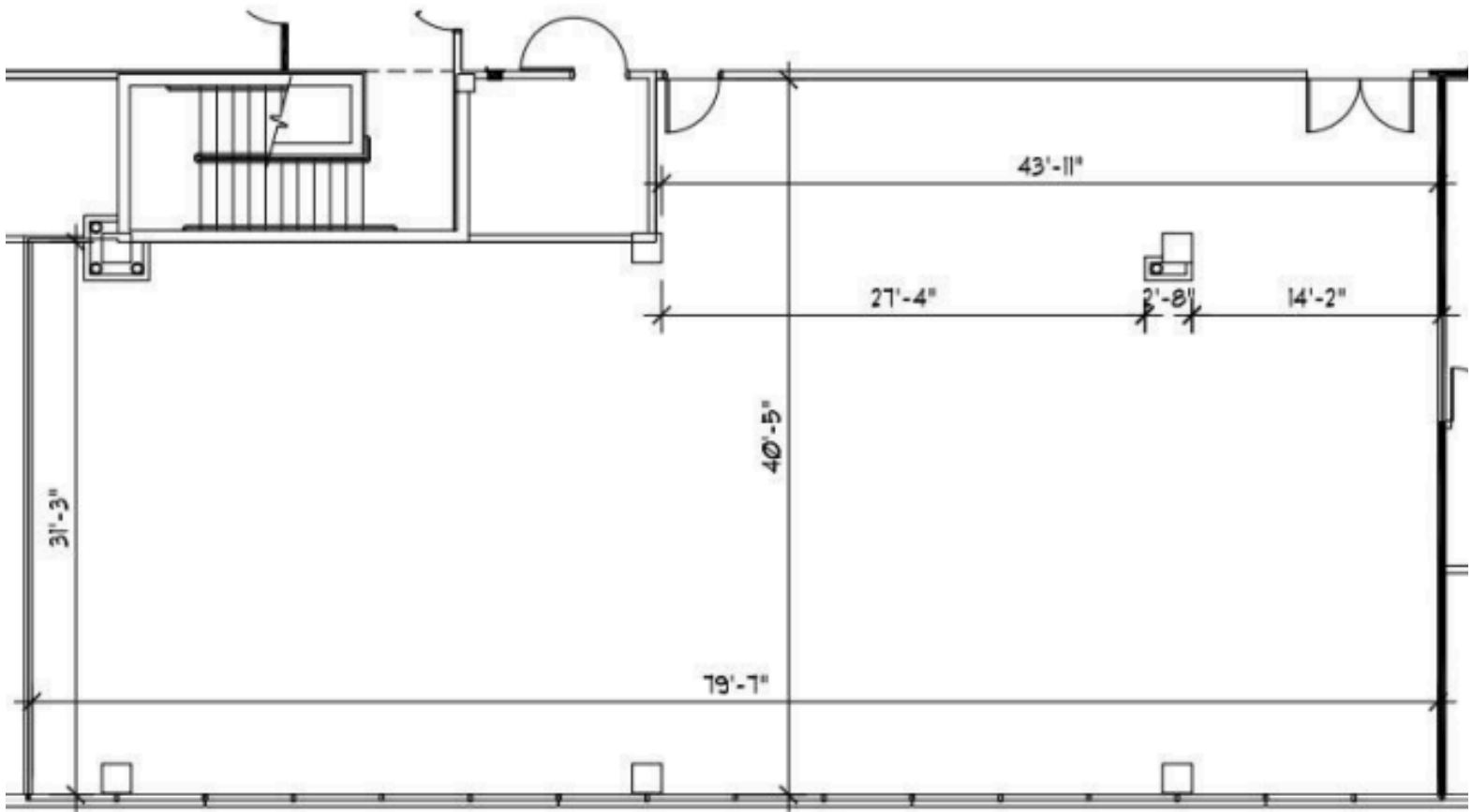

For more information please contact:

**Brady Titcomb**  
Executive Vice President  
brady.titcomb@jll.com  
+1 954 653 3222

**Kevin McCarthy**  
Senior Managing Director  
kevin.mccarthy@jll.com  
+1 561 292 2668

**Kevin Probel**  
Senior Managing Director  
kevin.probel@jll.com  
+1 561 676 2131

