

# PROPOSED MEDICAL BUILDING RENOVATION AND ADDITION 111 E82ND STREET, NEW YORK, NEW YORK

## DRAWING INDEX:

### ARCHITECTURAL

- A-001.01 COVER SHEET
- A-002.01 DRAWING DATA
- A-100.01 FLOOR PLANS
- A-101.01 FLOOR PLANS
- A-102.01 FLOOR PLANS
- A-200.01 REFLECTED CEILING PLANS
- A-201.01 REFLECTED CEILING PLANS
- A-202.01 REFLECTED CEILING PLANS
- A-300.01 EXISTING ELEVATION
- A-301.01 EXISTING ELEVATION
- A-302.01 PROPOSED ELEVATION
- A-303.01 PROPOSED ELEVATION
- A-304.01 LOBBY ELEVATION
- A-305.01 TYPICAL FLOOR ELEVATIONS
- A-400.01 SECTIONS
- A-401.01 SECTIONS
- A-402.01 SECTIONS

### STRUCTURAL

- S-001.00 STRUCTURAL NOTES
- S-100.00 CELLAR AND 1ST FLOOR FRAMING PLANS
- S-101.00 2ND AND 3RD FLOOR FRAMING PLANS
- S-102.00 4TH AND 5TH FLOOR FRAMING PLANS
- S-103.00 6TH AND ROOF FLOOR FRAMING PLANS
- S-400.00 BRACING WALL ELEVATION AND DETAILS
- S-500.00 FOUNDATION SECTIONS AND DETAILS

NUMBER	DATE	ISSUED FOR:
1	1/20/12	50 % DESIGN DEVELOPMENT SET

**111 E82ND STREET**  
**NEW YORK, NEW YORK**

**GARAGE MANAGEMENT COMPANY**  
 770 LEXINGTON AVENUE, 11TH FLOOR  
 NEW YORK, NEW YORK 10065

**DANIEL GOLDNER ARCHITECTS**  
 143 WEST 29TH STREET  
 NEW YORK, NY 10001  
 TEL: 212.268.8511  
 FAX: 212.268.1129

**WEXLER ASSOCIATES**  
 12 W32ND STREET, 8TH FLOOR  
 TEL: 212.643.1500  
 FAX: 212.643.2277  
 INFO@NWEXLER.COM

**LEGEND**

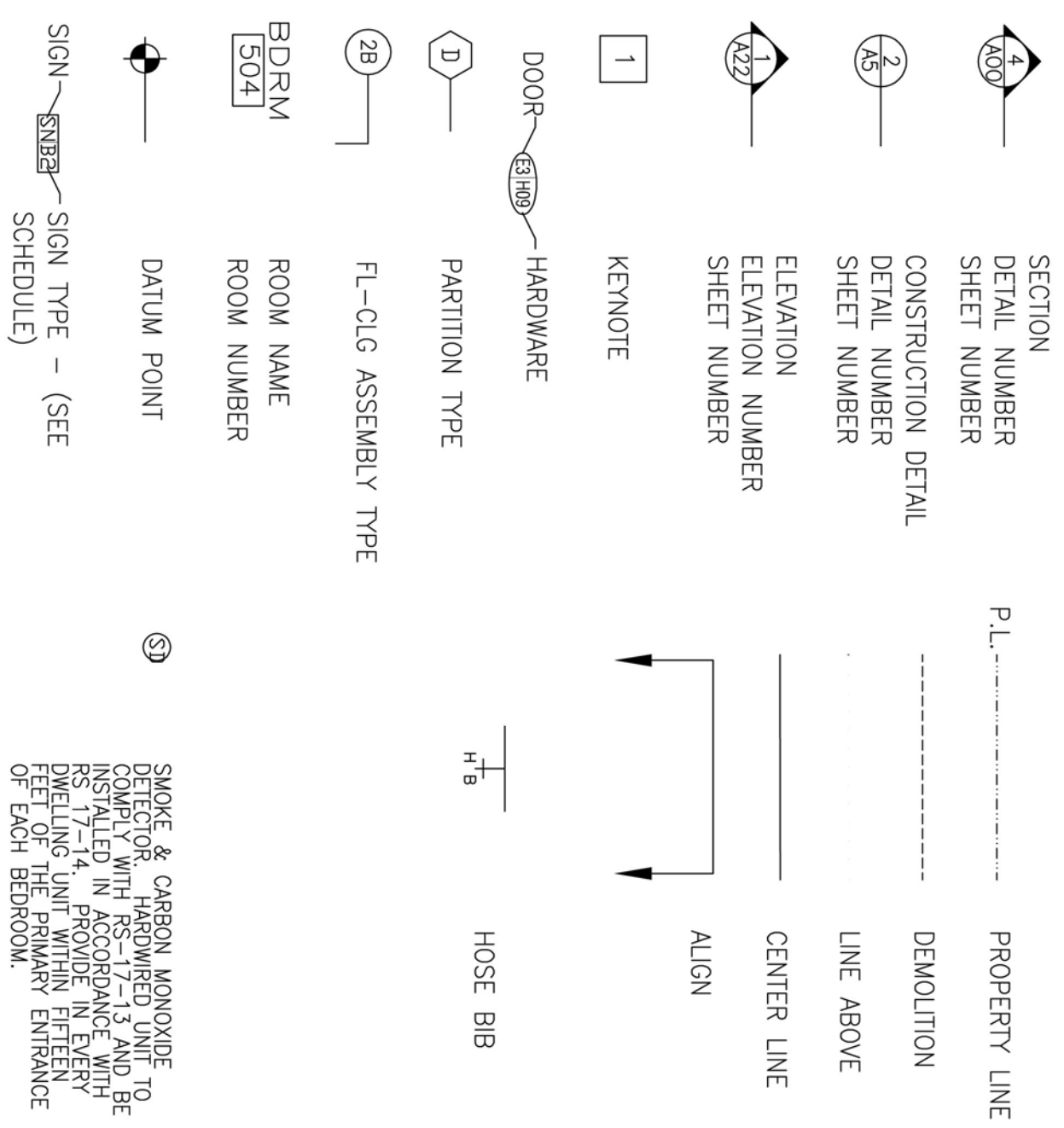

**ABBREVIATIONS**

A.F.F.	ABOVE FINISHED FLOOR	O.C.	ON CENTER
ALUM.	ALUMINUM	ORNG.	OPENING
APPROX.	APPROXIMATELY	PAN.	PANTRY
BLDG.	BUILDING	PLYWD.	PLYWOOD
B.O.I.C.	BY OWNER, CONTRACTOR INSTALLED	P.F.L.	PROPERTY LINE
BOT.	BOTTOM	R.C.P.	REFLECTED CEILING PLAN
CAB.	CABINET	R.O.	ROUGH OPENING
C.I.P.	CAST IN PLACE	SCHED.	SCHEDULE
CLG.	CEILING	SECT.	SECTION
C.M.U.	CONCRETE MASONRY UNIT	SIM.	SIMILAR
CONG.	CONCRETE	S.O.G.	SLAB ON GRADE
DTL.	DETAIL	S.J.	STEEL JOIST
DWG.	DRAWING	S.S.	STAINLESS STEEL
EA.	EACH	STC.	SOUND TRANSMISSION CLASS
EQ.	EQUAL	STD.	STANDARD
EXIST.	EXISTING	STL.	STEEL
EXT.	EXTERIOR	T	THERMOSTAT
FIN.	FINISH	T&B	TOP AND BOTTOM
F.D.	FLOOR DRAIN	T.B.D.	TO BE DETERMINED
F.L.	FLOOR	TRP.	TYPICAL
F.P.S.C.	FIRE PROOF SELF-CLOSING	U.O.N.	UNLESS OTHERWISE NOTED
GA.	GAUGE	V.F.	VERIFY
G.C.	GENERAL CONTRACTOR	V.I.F.	VERIFY IN FIELD
G.W.B.	GYPSUM WALL BOARD	WD.	WOOD
HD.	HEAD	WDW.	WINDOW
INT.	INTERIOR	W.P.	WATERPROOF
JST.	JOIST	W/W	WITH
J-BOX	JUNCTION BOX	W/O	WITHOUT
MECH.	MECHANICAL		
MIN.	MINIMUM		
M.O.	MASONRY OPENING		
N.I.C.	NOT IN CONTRACT		
N.T.S.	NOT TO SCALE		

**SITE PLAN**

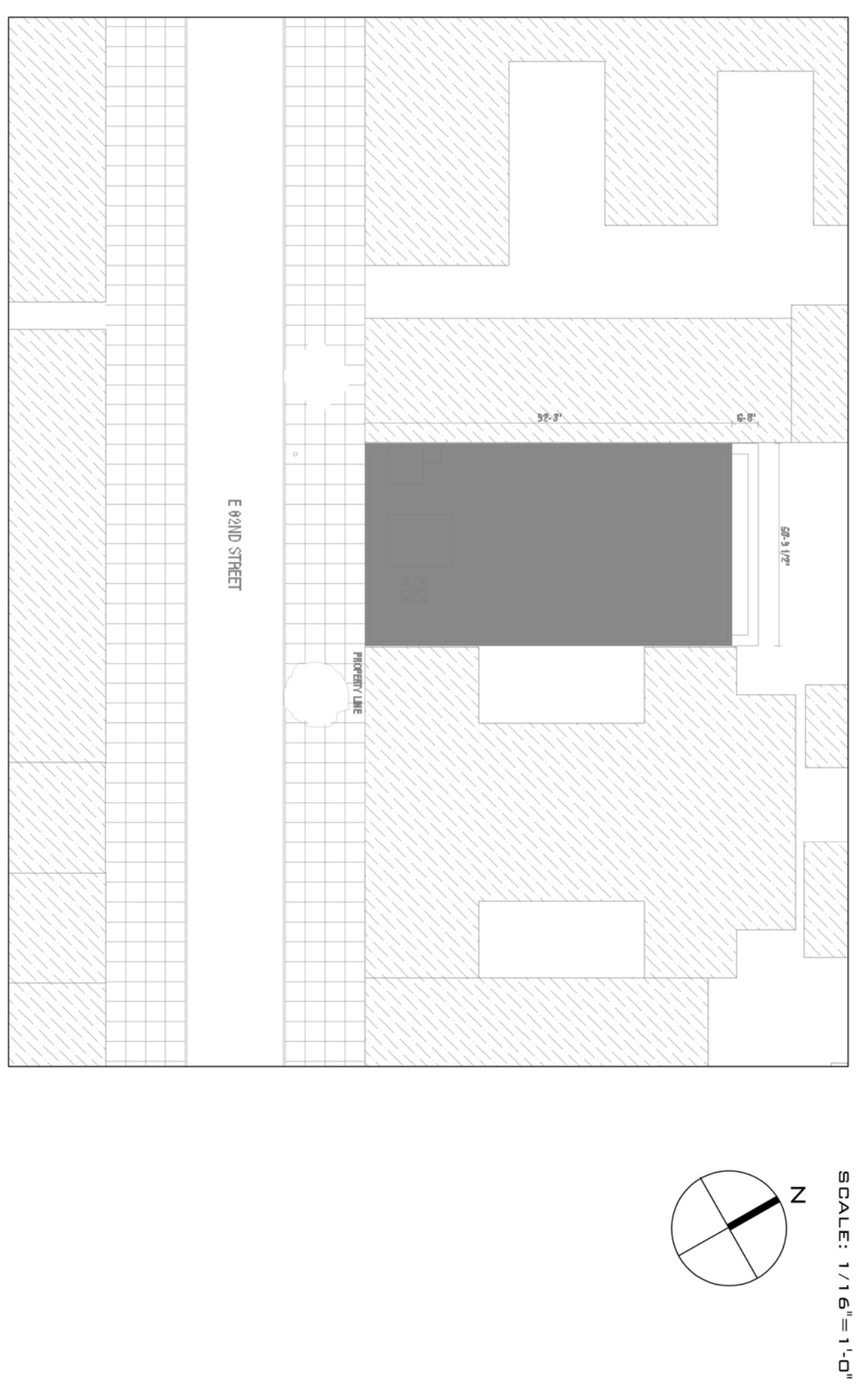

**ZONING CALCULATIONS**

111 East 82nd Street  
New York, NY 10011  
Block : 6  
Lot : 8  
Map : R88  
Zone :

Lot area = 5,108  
MAX. ZONING FLOOR AREA (ZFA)  
Lot AREA : 5,108  
Lot FAR : 5.1  
MAX ZFA : 26,051  
Com Floor = 5,108 X 5.1 = 26,051  
TOTAL = 26,051

FLOOR	EXISTING		NEW		TOTAL F.A.	TOTAL ZFA	HEIGHT	CUMULATIVE
	FA	ZFA	FA	ZFA				
**Cellar	4,685	4,357	4,685	4,357	4,685	4,357	14.20	16.58
Floor 1	4,685	4,357	4,685	4,357	4,685	4,357	12.75	29.33
Floor 2	4,685	4,357	4,685	4,357	4,685	4,357	12.17	41.50
Floor 3	4,685	4,357	4,685	4,357	4,685	4,357	14.50	56.00
Floor 4	4,685	4,357	4,685	4,357	4,685	4,357	9.50	65.50
Floor 5	4,685	4,357	4,685	4,357	4,685	4,357	9.50	75.00
TOTAL F.A.	23,425	21,282	23,425	21,282	23,425	21,282		
TOTAL ZFA		17,282		4,754		22,182		

\*\* NOT INCLUDED IN ZONING FLOOR AREA TOTAL AMENDED CO RECORD TO CHANGE TO CEILING FROM BASEMENT  
MAXIMUM COM. FAC. LOT COVERAGE : 70% = 3,576  
COM. FAC. FLOOR AREA : 3,576  
NOTE: TOTAL GROSS BLDG. SIZE = 28855 SF

**ZONING DIAGRAM**

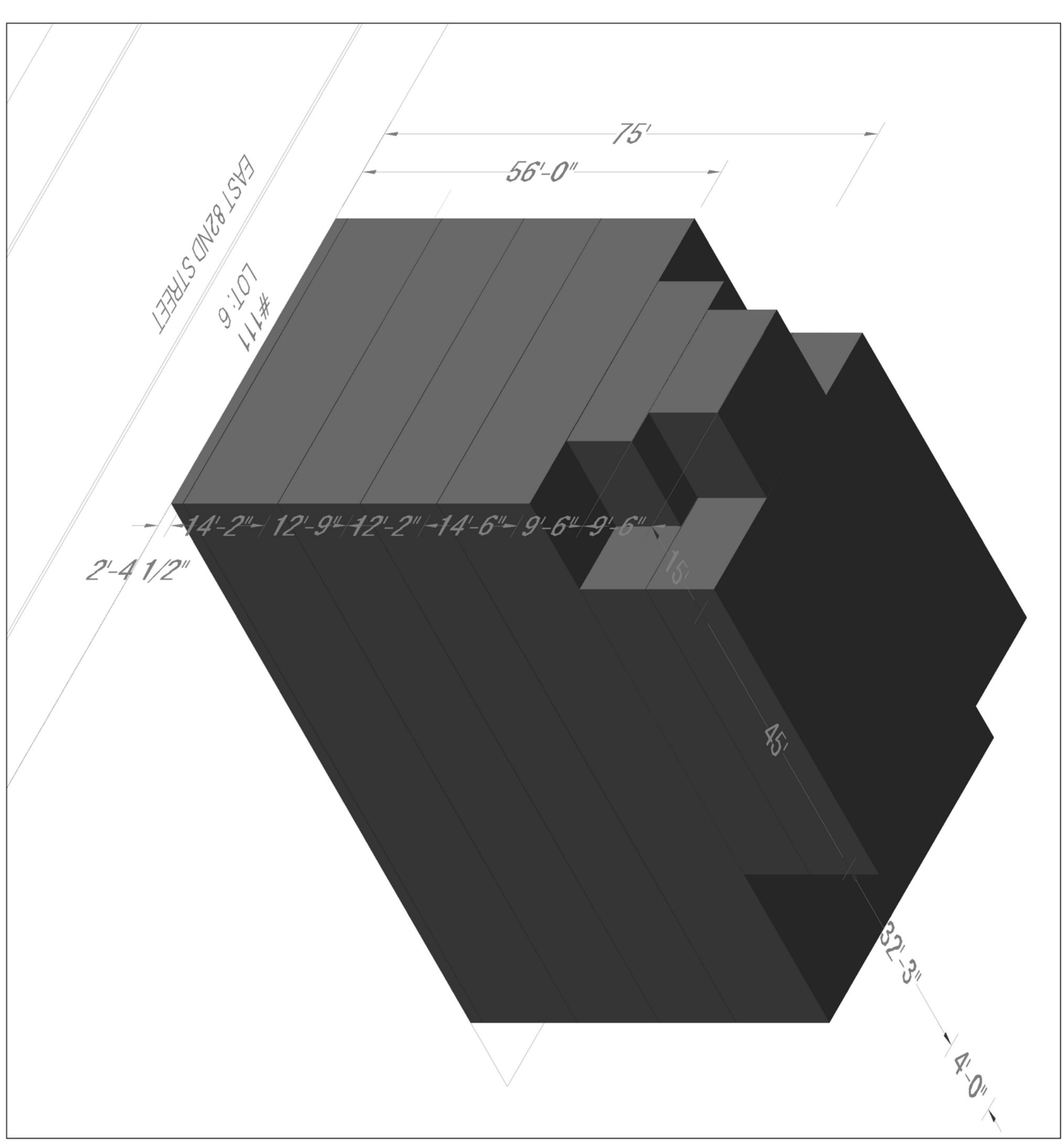

**DEMOLITION NOTES:**

1. REMOVE ANY EXISTING CONDITIONS TO MEET NEW CONSTRUCTION
2. CORRELATE DEMOLITION WITH NEW FRONT FACADE

NUMBER	DATE	ISSUED FOR
1	1/20/12	50 % DESIGN DEVELOPMENT SET

111 E82ND STREET  
NEW YORK, NEW YORK  
GARAGE MANAGEMENT COMPANY  
770 LEXINGTON AVENUE, 11TH FLOOR  
NEW YORK, NEW YORK 10065

DANIEL GOLDNER ARCHITECTS  
143 WEST 29TH STREET  
NEW YORK, NY 10001  
TEL: 212.268.8511  
FAX: 212.268.1129

WEXLER ASSOCIATES  
112 W32ND STREET, 8TH FLOOR  
TEL: 212.643.1500  
FAX: 212.643.2277  
INFO@NWEXLER.COM

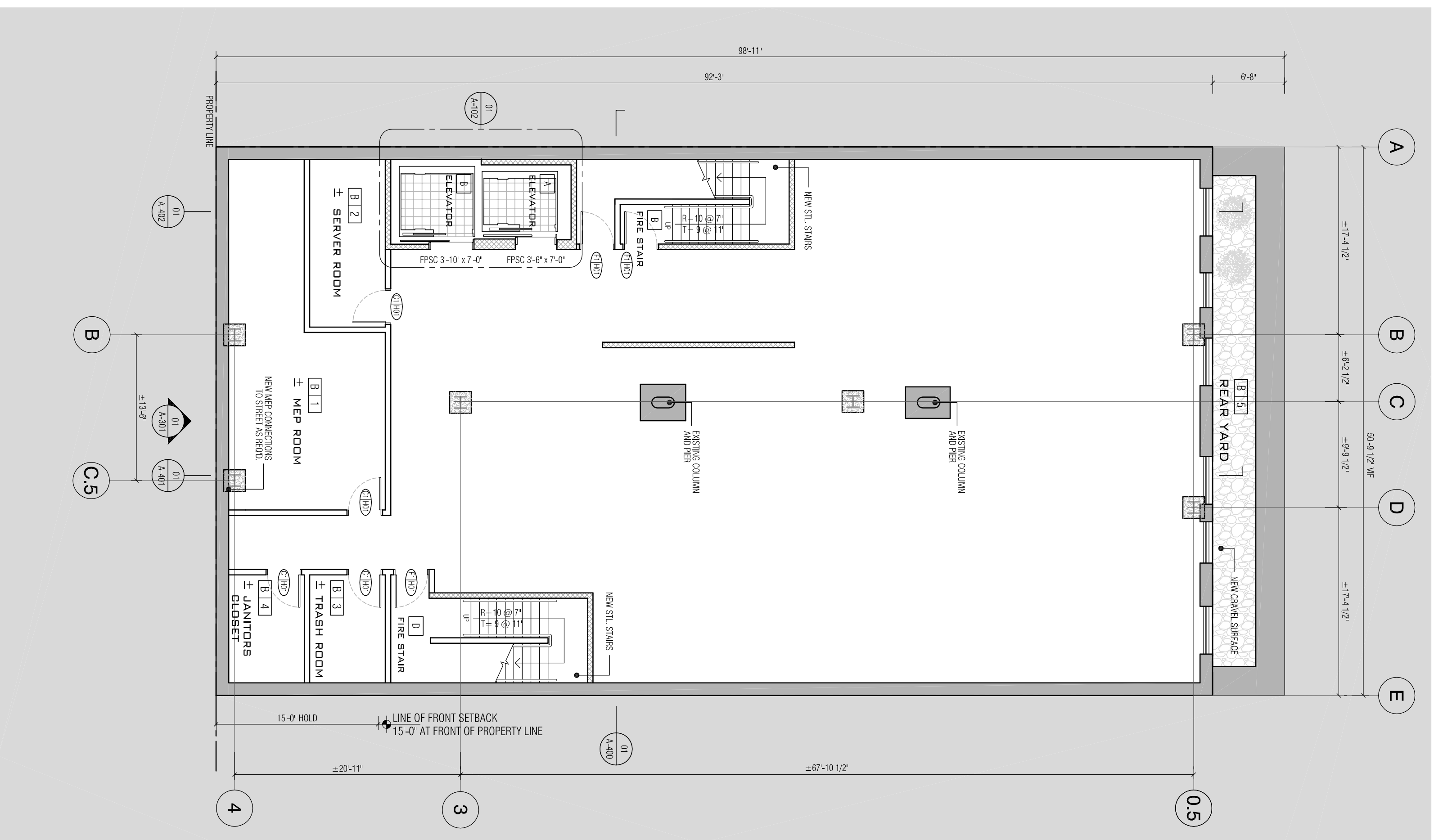

01 CELLAR PLAN

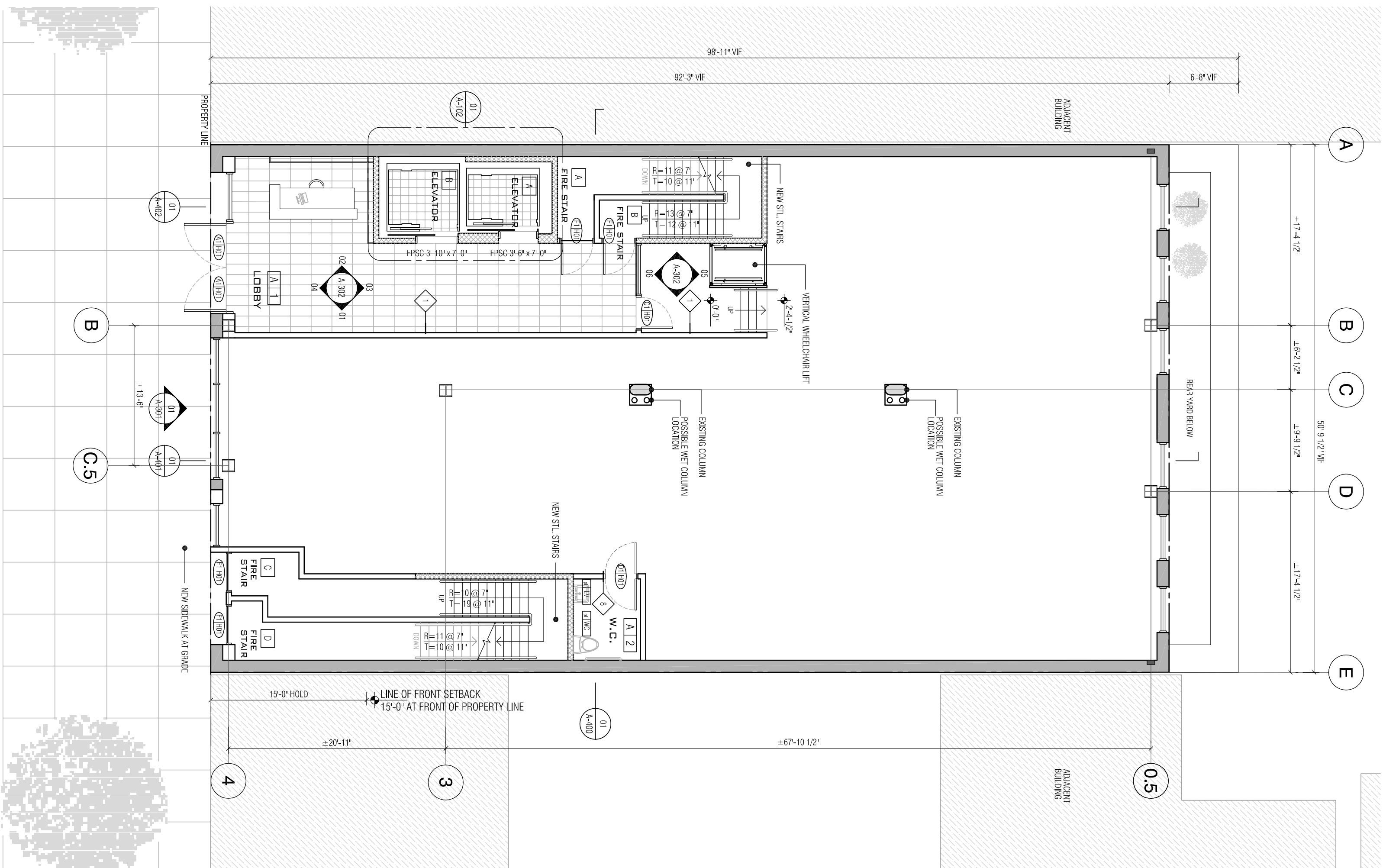

02 1ST FLOOR PLAN

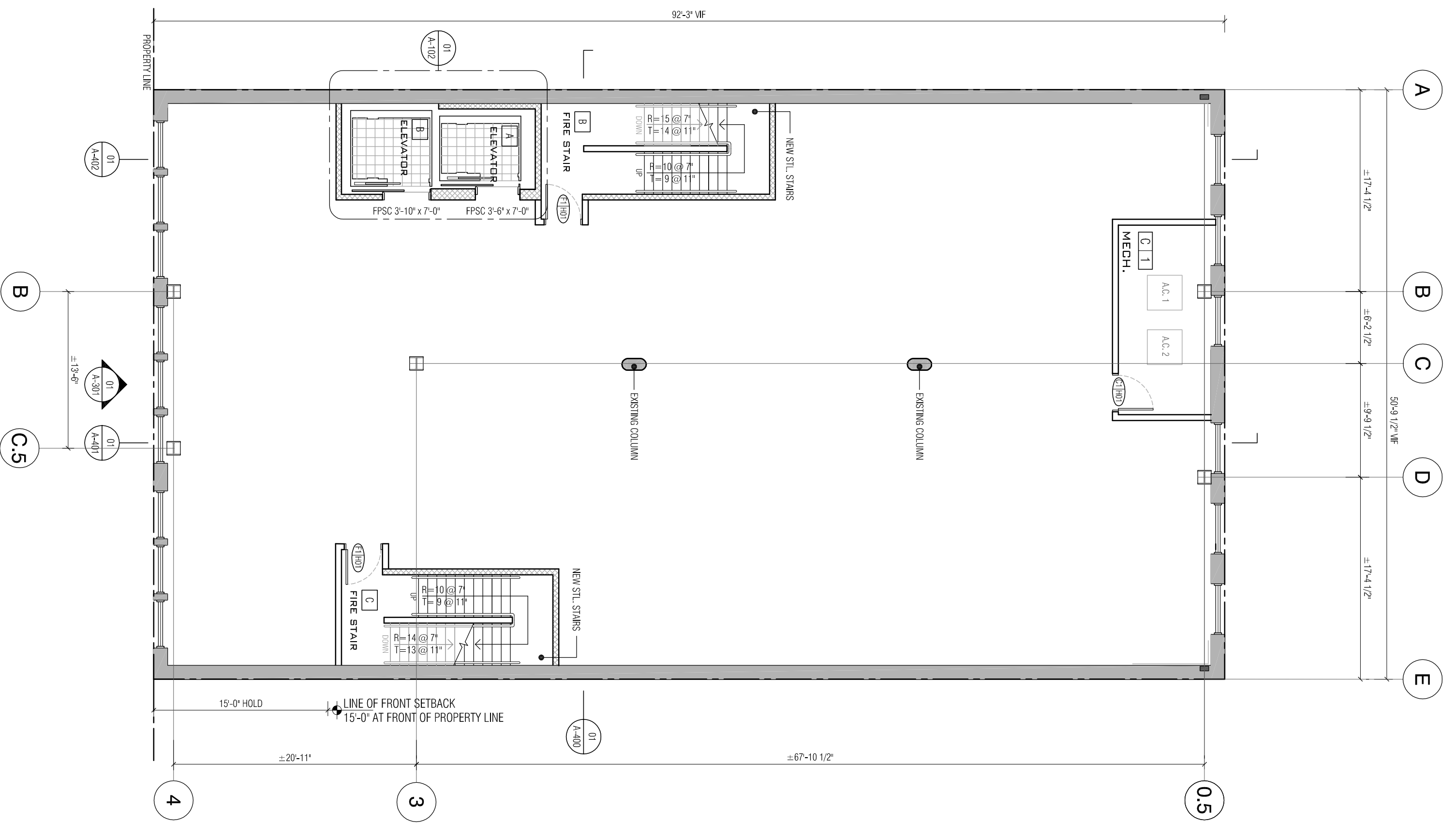

03 2ND FLOOR PLAN

**LEGEND**

	EXISTING WALL
	NEW CMU WALL
	NEW WALL

- DEMOLITION NOTES:**
- REMOVE ANY EXISTING CONDITIONS TO MEET NEW CONSTRUCTION
  - CORRELATE DEMOLITION WITH NEW FRONT FACADE

NUMBER	DATE	ISSUED FOR:
1	1/20/13	50 % DESIGN DEVELOPMENT SET

**111 EB2ND STREET**  
 NEW YORK, NEW YORK  
**GARAGE MANAGEMENT COMPANY**  
 770 LEVINGTON AVENUE, 11TH FLOOR  
 NEW YORK, NEW YORK 10065

**DANIEL GOLDNER ARCHITECTS**  
 143 WEST 29TH STREET  
 NEW YORK, NY 10001  
 TEL: 212.268.8511  
 FAX: 212.268.1129

**WEXLER ASSOCIATES**  
 SENIOR ENGINEER  
 12 W 2ND STREET, 8TH FLOOR  
 TEL: 212.643.1500  
 FAX: 212.643.2277  
 INFO@NWEXLER.COM

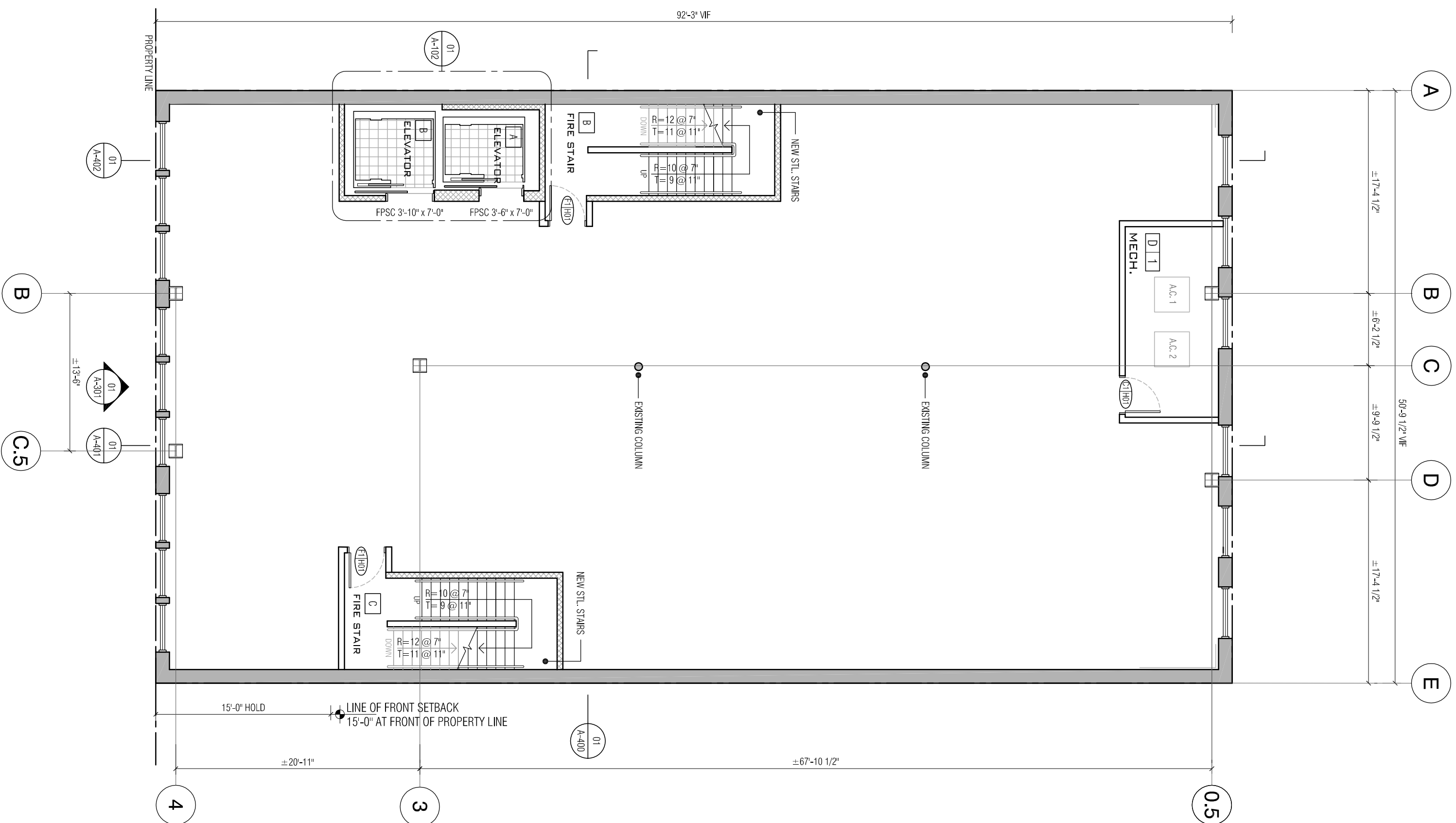

01 3RD FLOOR PLAN

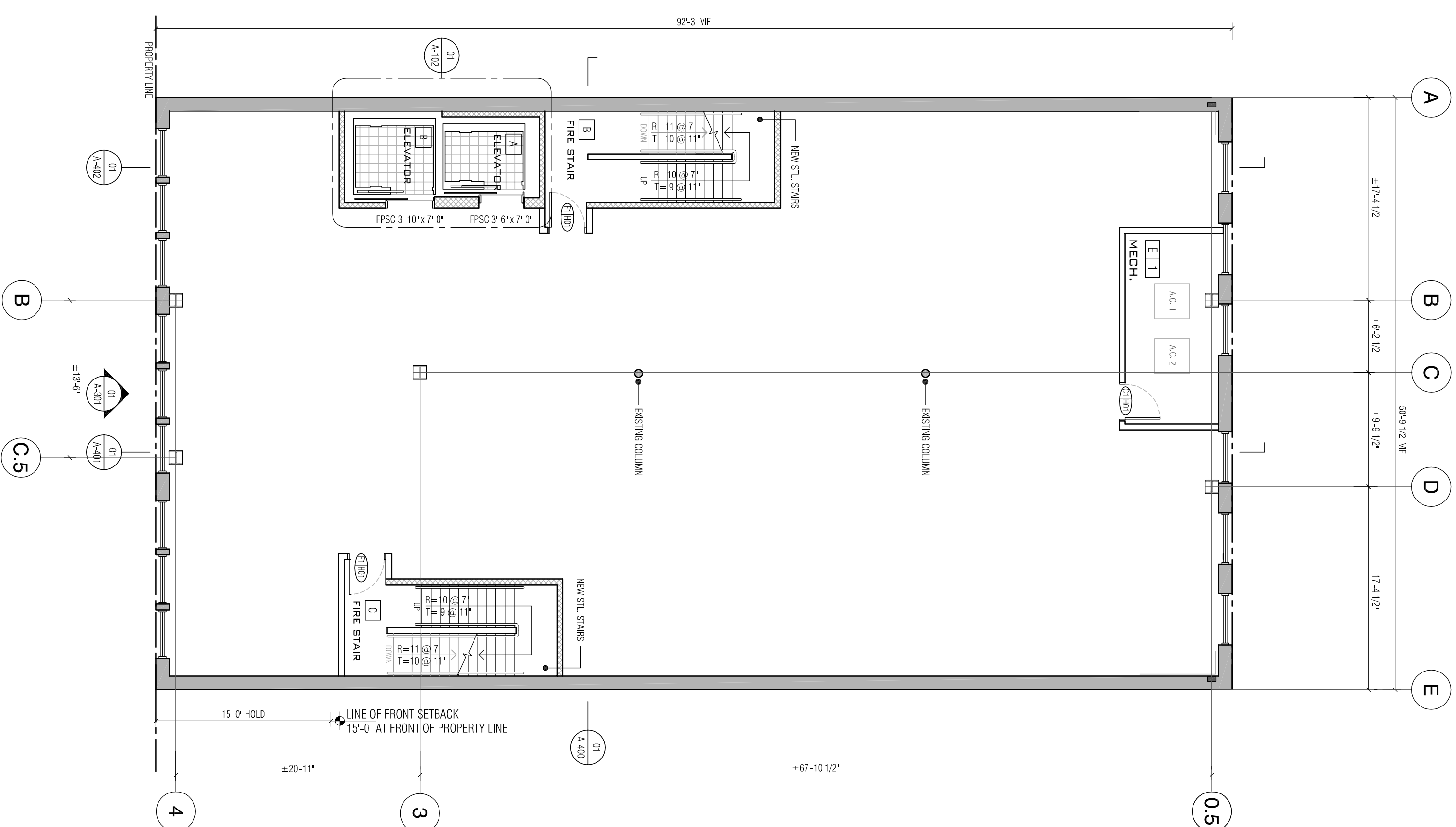

02 4TH FLOOR PLAN

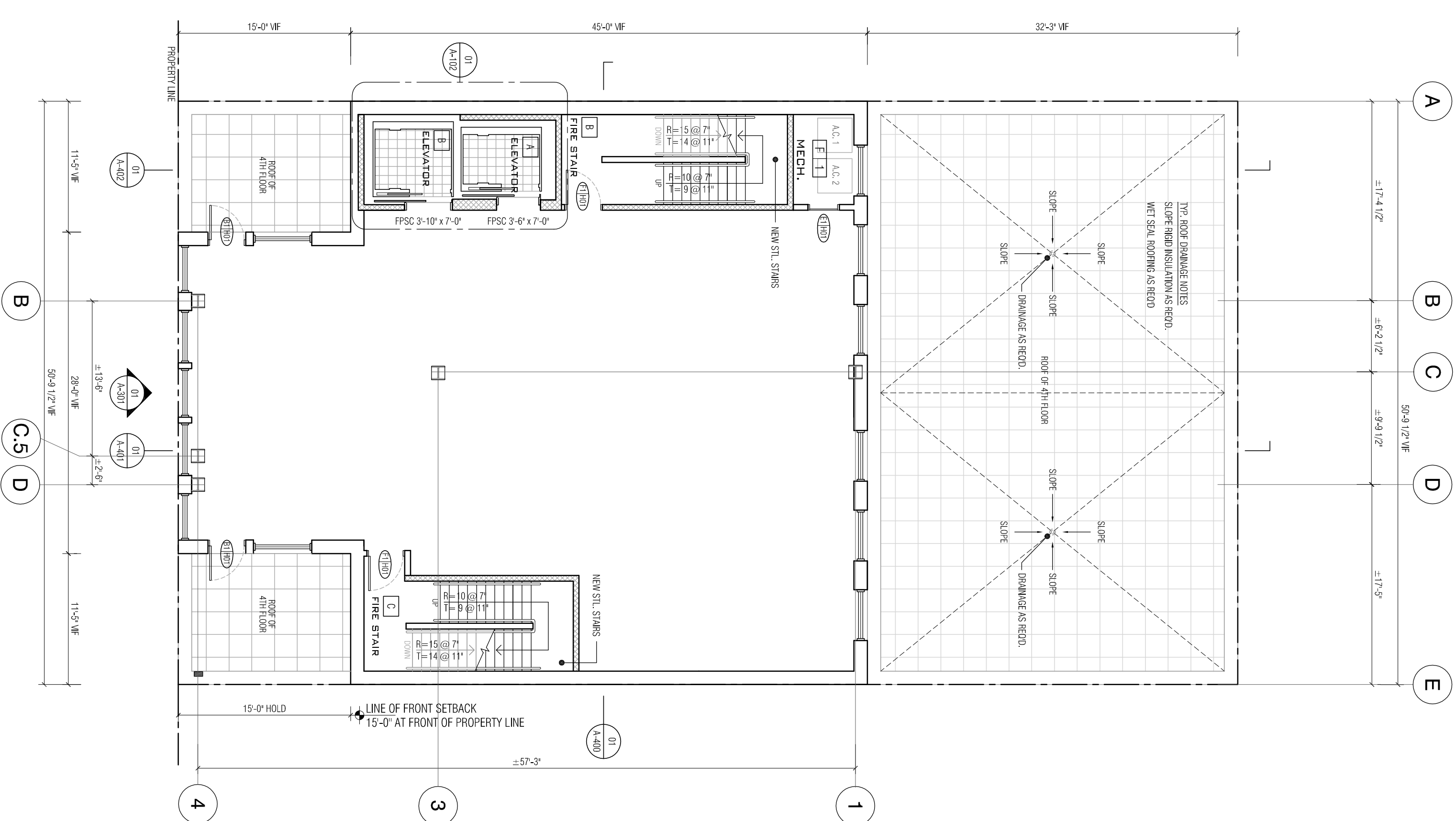

03 5TH FLOOR PLAN

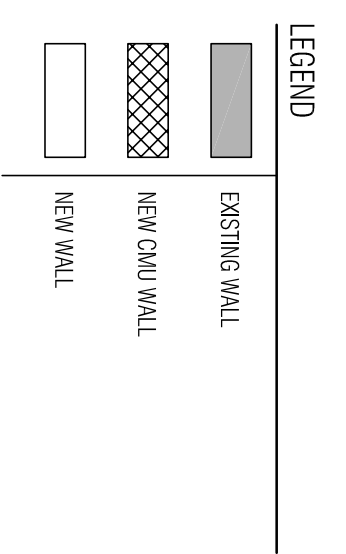

- DEMOLITION NOTES:**
- REMOVE ANY EXISTING CONDITIONS TO MEET NEW CONSTRUCTION
  - CORRELATE DEMOLITION WITH NEW FRONT FACADE

NUMBER	DATE	ISSUED FOR:
1	1/20/13	50 % DESIGN DEVELOPMENT SET

**111 EB2ND STEET**  
 NEW YORK, NEW YORK  
**GARAGE MANAGEMENT COMPANY**  
 770 LEXINGTON AVENUE, 11TH FLOOR  
 NEW YORK, NEW YORK 10065

**DANIEL GOLDNER ARCHITECTS**  
 143 WEST 29TH STREET  
 NEW YORK, NY 10001  
 TEL: 212.268.8511  
 FAX: 212.268.1129

**WEXLER ASSOCIATES**  
 12 W2ND STREET, 8TH FLOOR  
 TEL: 212.643.1500  
 FAX: 212.643.2277  
 INFO@NWEXLER.COM



01

CELLAR REFLECTED CEILING PLAN

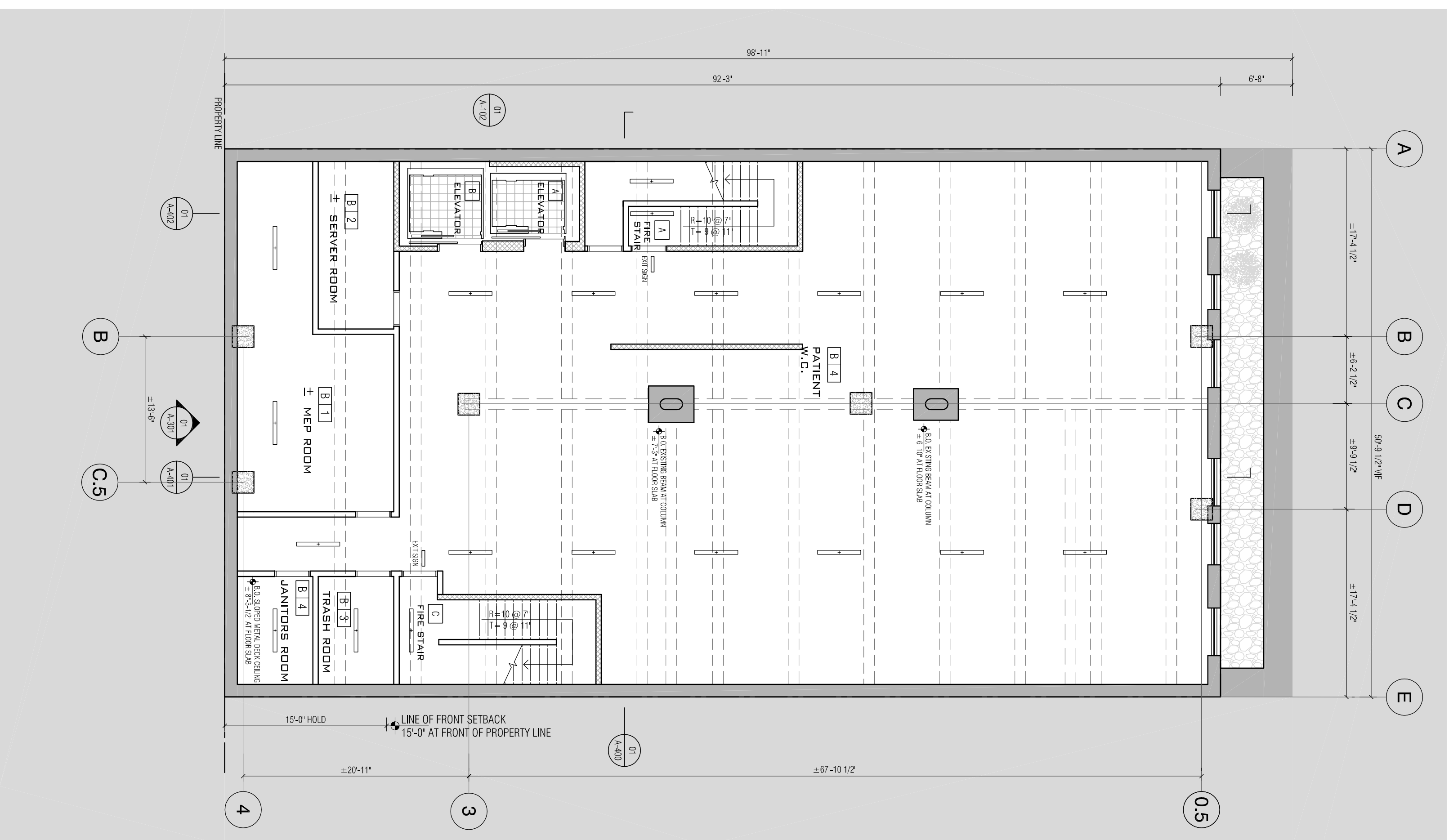

02

1ST FLOOR REFLECTED CEILING PLAN

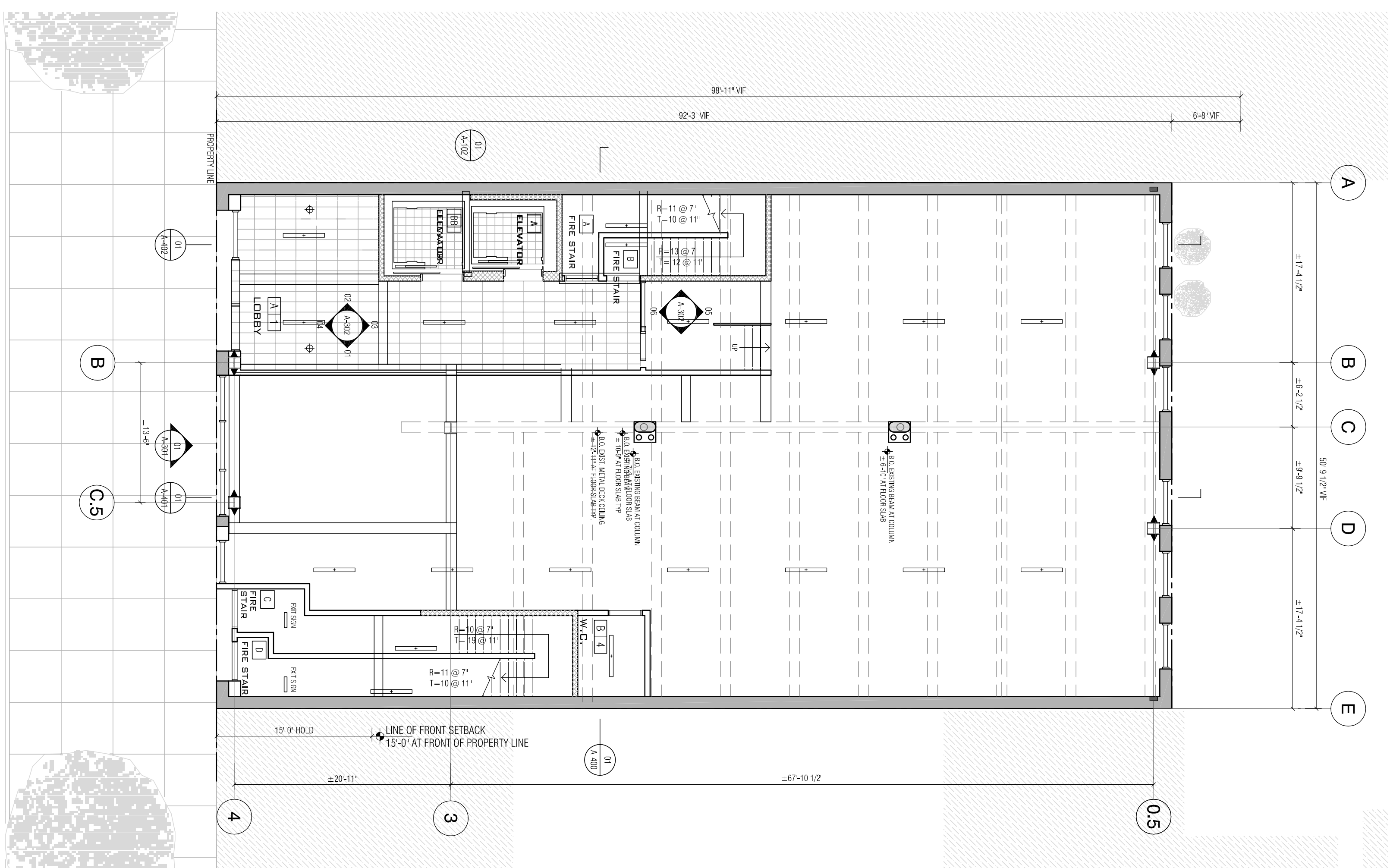

03

2ND FLOOR REFLECTED CEILING PLAN

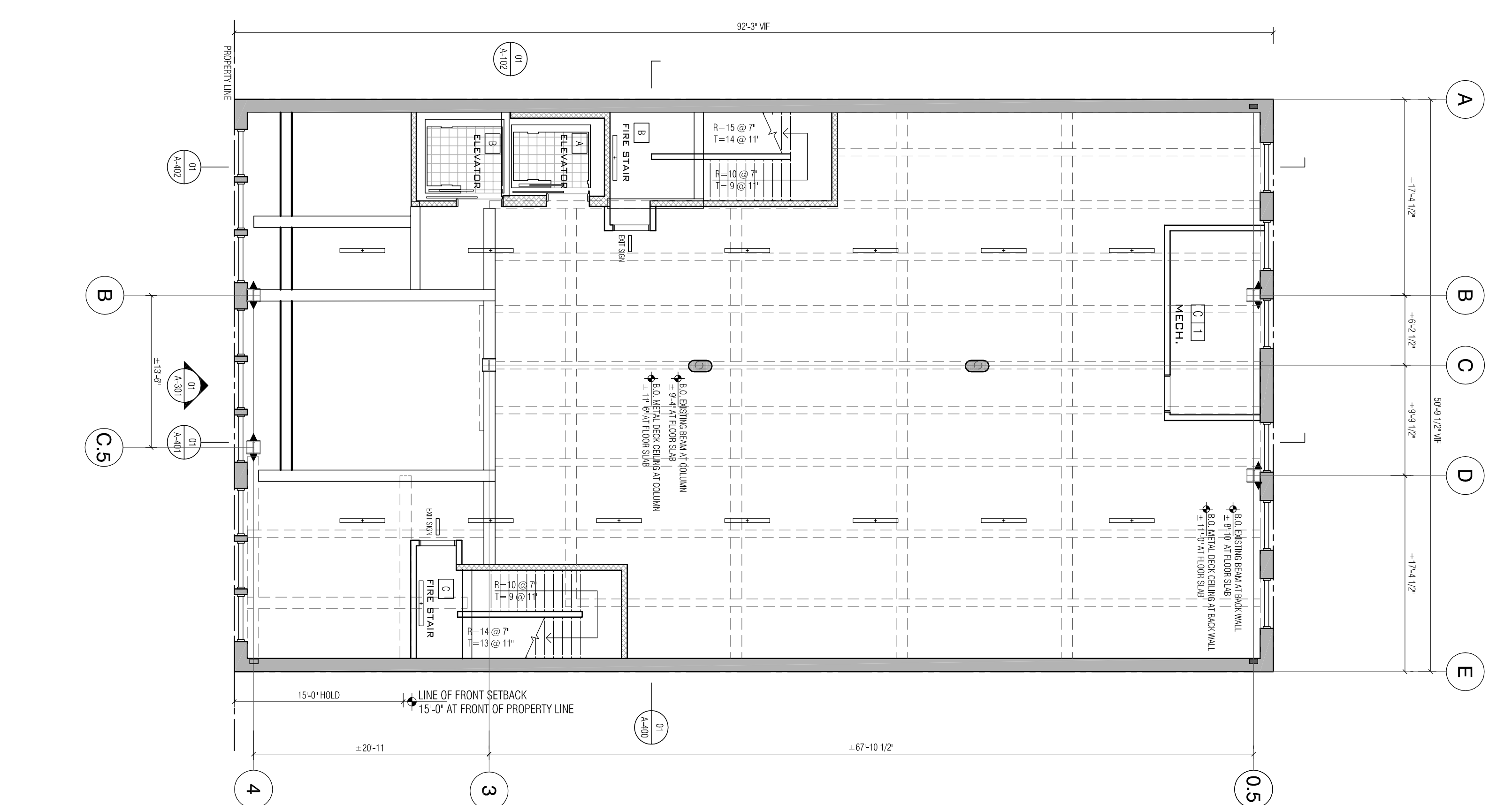

**LEGEND**

	EXISTING WALL
	NEW CMU WALL
	NEW WALL
	EXISTING BEAM
	NEW STEEL BEAM
	NEW C JOIST
	NEW MOVEMENT CONNECTION

- DEMOLITION NOTES:**
1. REMOVE ANY EXISTING CONDITIONS TO MEET NEW CONSTRUCTION
  2. CORRELATE DEMOLITION WITH NEW FRONT FACADE

NUMBER DATE:	ISSUED FOR:
1 1/2004/12	50 % DESIGN DEVELOPMENT SET

**111 EB2ND STREET**  
 NEW YORK, NEW YORK  
**GARAGE MANAGEMENT COMPANY**  
 770 LEXINGTON AVENUE, 11TH FLOOR  
 NEW YORK, NEW YORK 10065

**DANIEL GOLDNER ARCHITECTS**  
 143 WEST 29TH STREET  
 NEW YORK, NY 10001  
 TEL: 212.268.8511  
 FAX: 212.268.1129

**WEXLER ASSOCIATES**  
 12 W2ND STREET, 8TH FLOOR  
 TEL: 212.643.1500  
 FAX: 212.643.2277  
 INFO@NWEXLER.COM

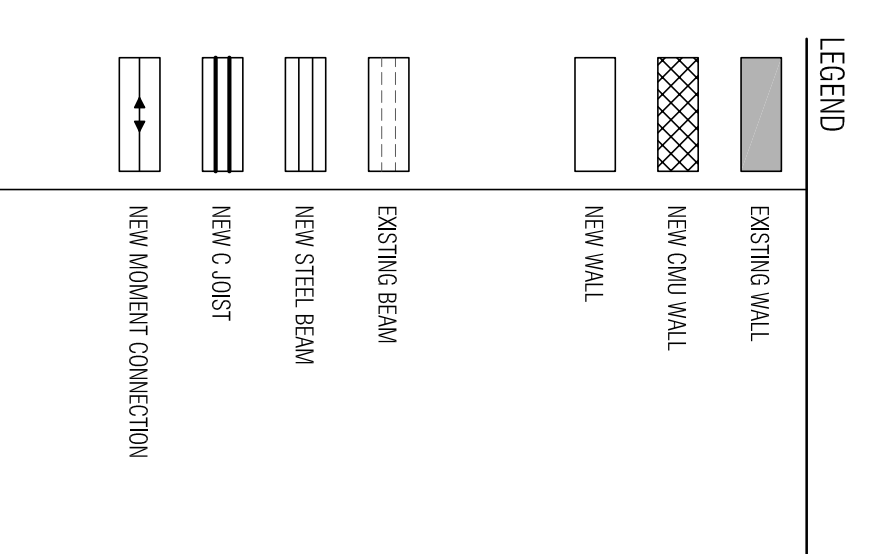
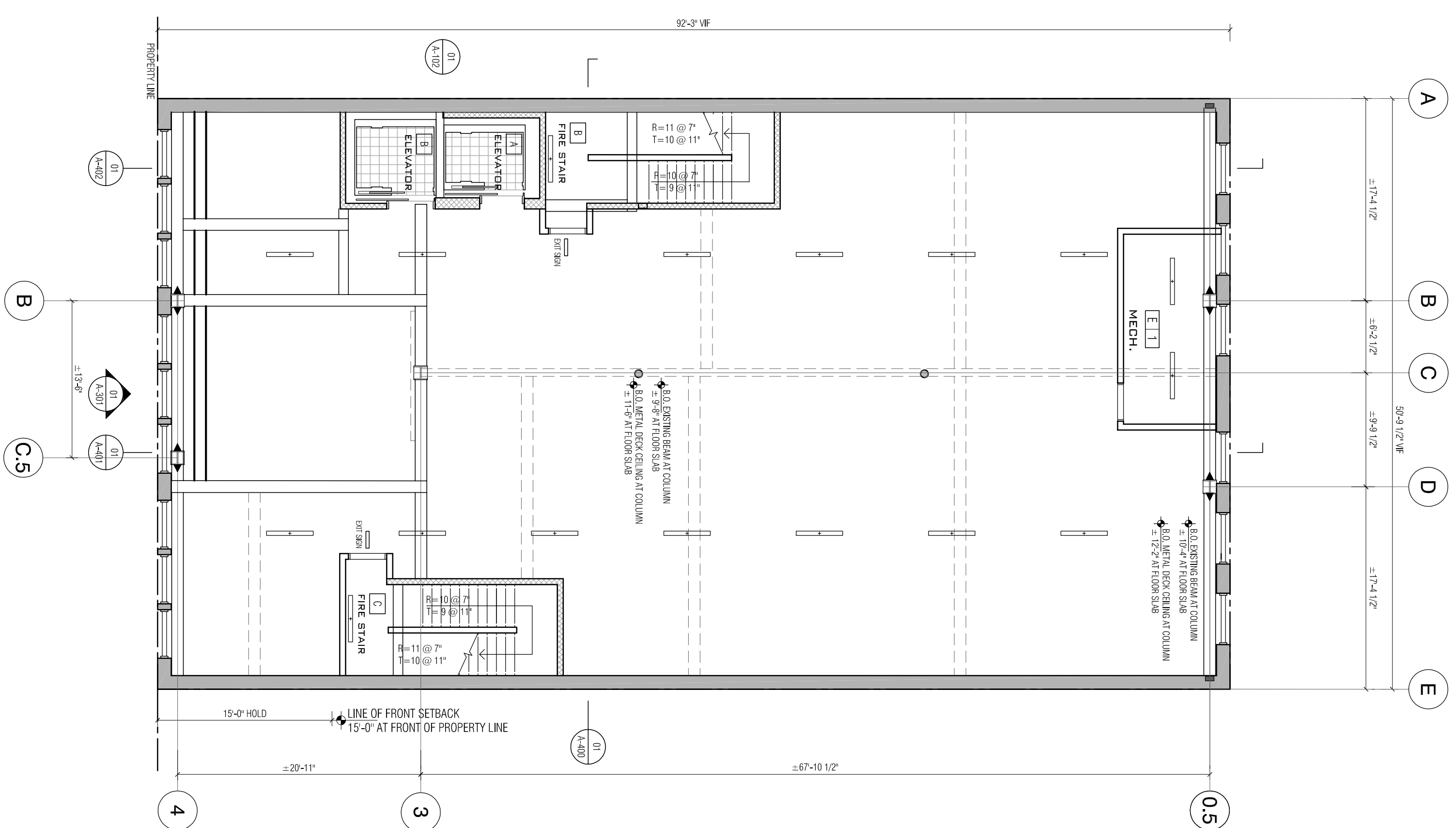
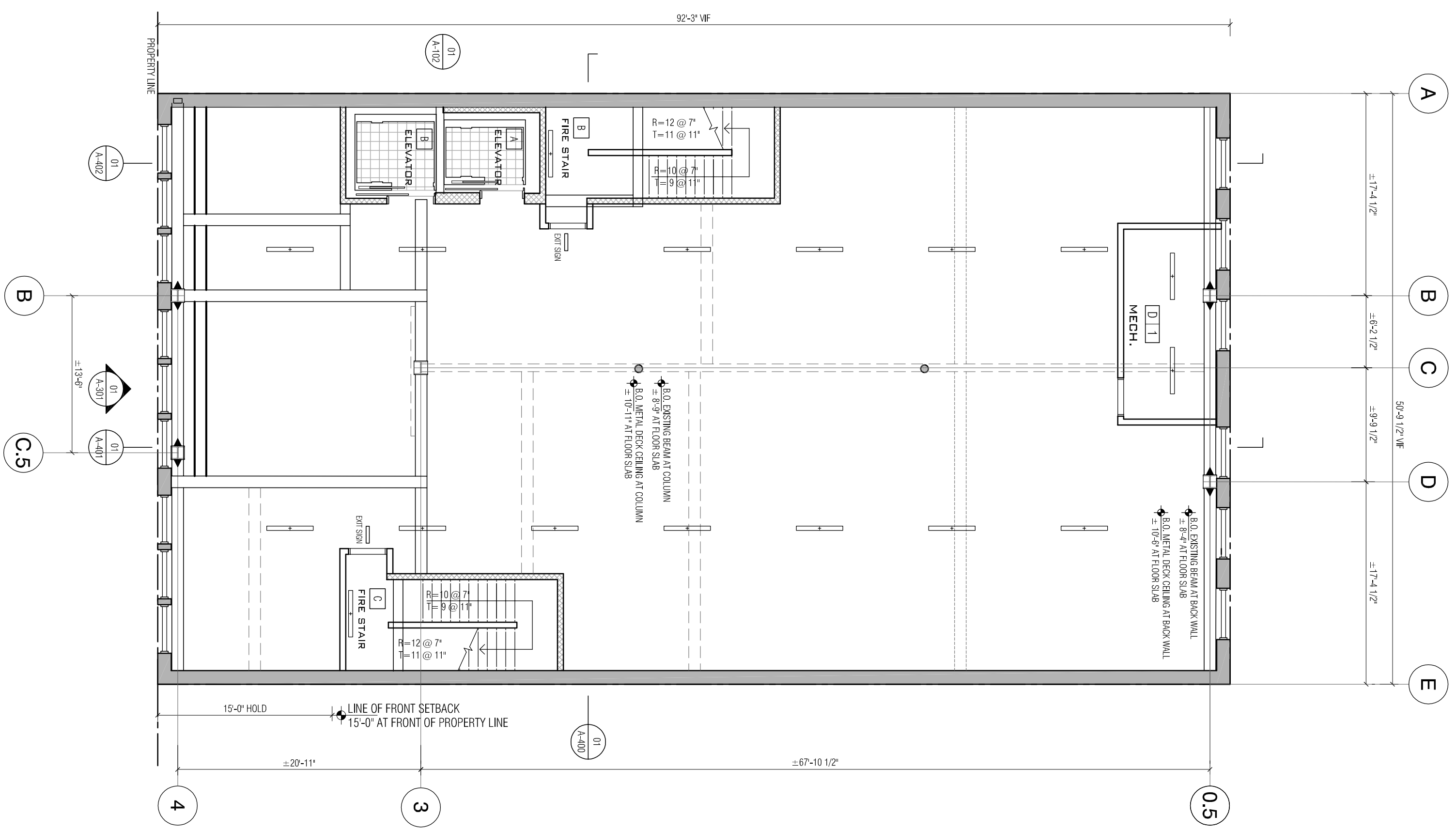

- DEMOLITION NOTES:**
- REMOVE ANY EXISTING CONDITIONS TO MEET NEW CONSTRUCTION
  - CORRELATE DEMOLITION WITH NEW FRONT FACADE

NUMBER	DATE	ISSUED FOR:
1	1/20/12	50 % DESIGN DEVELOPMENT SET

**111 EB2ND STEET**  
 NEW YORK, NEW YORK  
**GARAGE MANAGEMENT COMPANY**  
 770 LEXINGTON AVENUE, 11TH FLOOR  
 NEW YORK, NEW YORK 10065

**DANIEL GOLDNER ARCHITECTS**  
 143 WEST 29TH STREET  
 NEW YORK, NY 10001  
 TEL: 212.268.8511  
 FAX: 212.268.1129

**WEXLER ASSOCIATES**  
 12 W2ND STREET, 8TH FLOOR  
 TEL: 212.643.1500  
 FAX: 212.643.2277  
 INFO@NWEXLER.COM

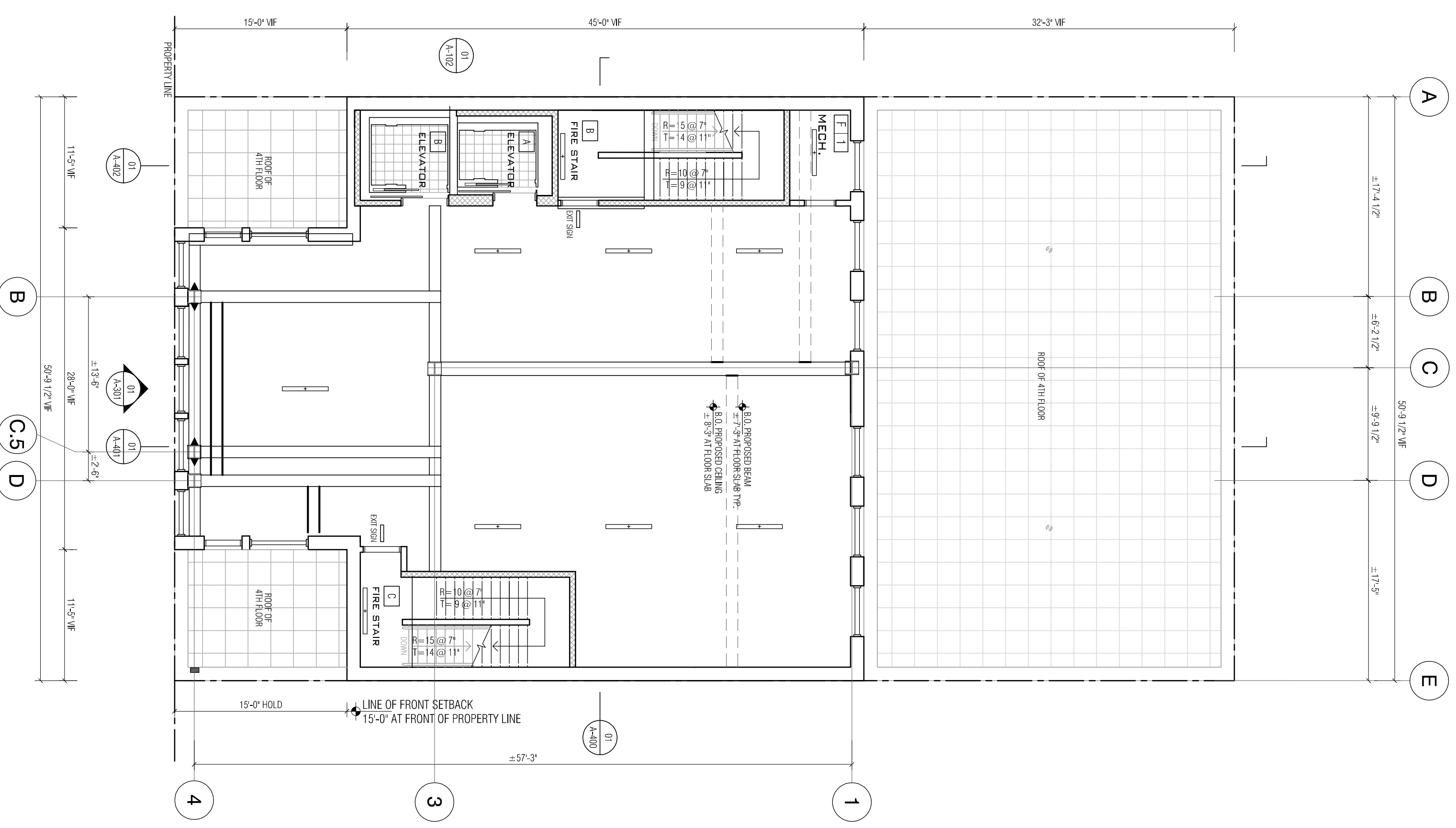

01 5TH FLOOR REFLECTED CEILING PLAN

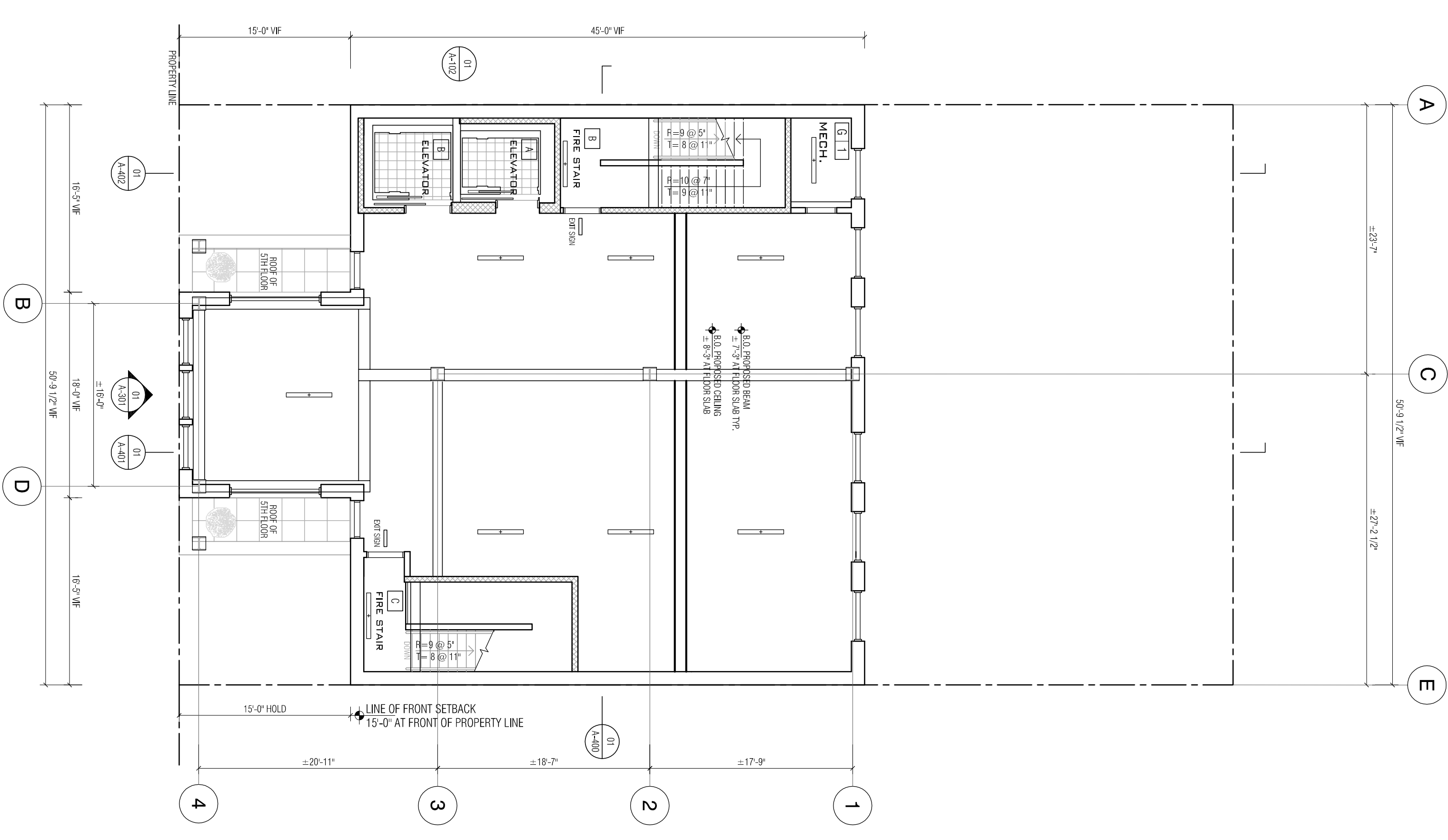

02 6TH FLOOR REFLECTED CEILING PLAN

**LEGEND**

	EXISTING WALL
	NEW CMU WALL
	NEW WALL
	EXISTING BEAM
	NEW STEEL BEAM
	NEW C JOIST
	NEW MOMENT CONNECTION

- DEMOLITION NOTES:**
1. REMOVE ANY EXISTING CONDITIONS TO MEET NEW CONSTRUCTION
  2. CORRELATE DEMOLITION WITH NEW FRONT FACADE

NUMBER	DATE	ISSUED FOR:
1	1/20/12	50 % DESIGN DEVELOPMENT SET

**111 EB2ND STEET**  
 NEW YORK, NEW YORK  
**GARAGE MANAGEMENT COMPANY**  
 770 LEXINGTON AVENUE, 11TH FLOOR  
 NEW YORK, NEW YORK 10065

**DANIEL GOLDNER ARCHITECTS**  
 143 WEST 29TH STREET  
 NEW YORK, NY 10001  
 TEL: 212.268.8511  
 FAX: 212.268.1129

**WEXLER ASSOCIATES**  
 12 W2ND STREET, 8TH FLOOR  
 TEL: 212.643.1500  
 FAX: 212.643.2277  
 INFO@NWEXLER.COM

- DEMOLITION NOTES:
1. REMOVE ANY EXISTING CONDITIONS TO MEET NEW CONSTRUCTION
  2. CORRELATE DEMOLITION WITH NEW FRONT FACADE

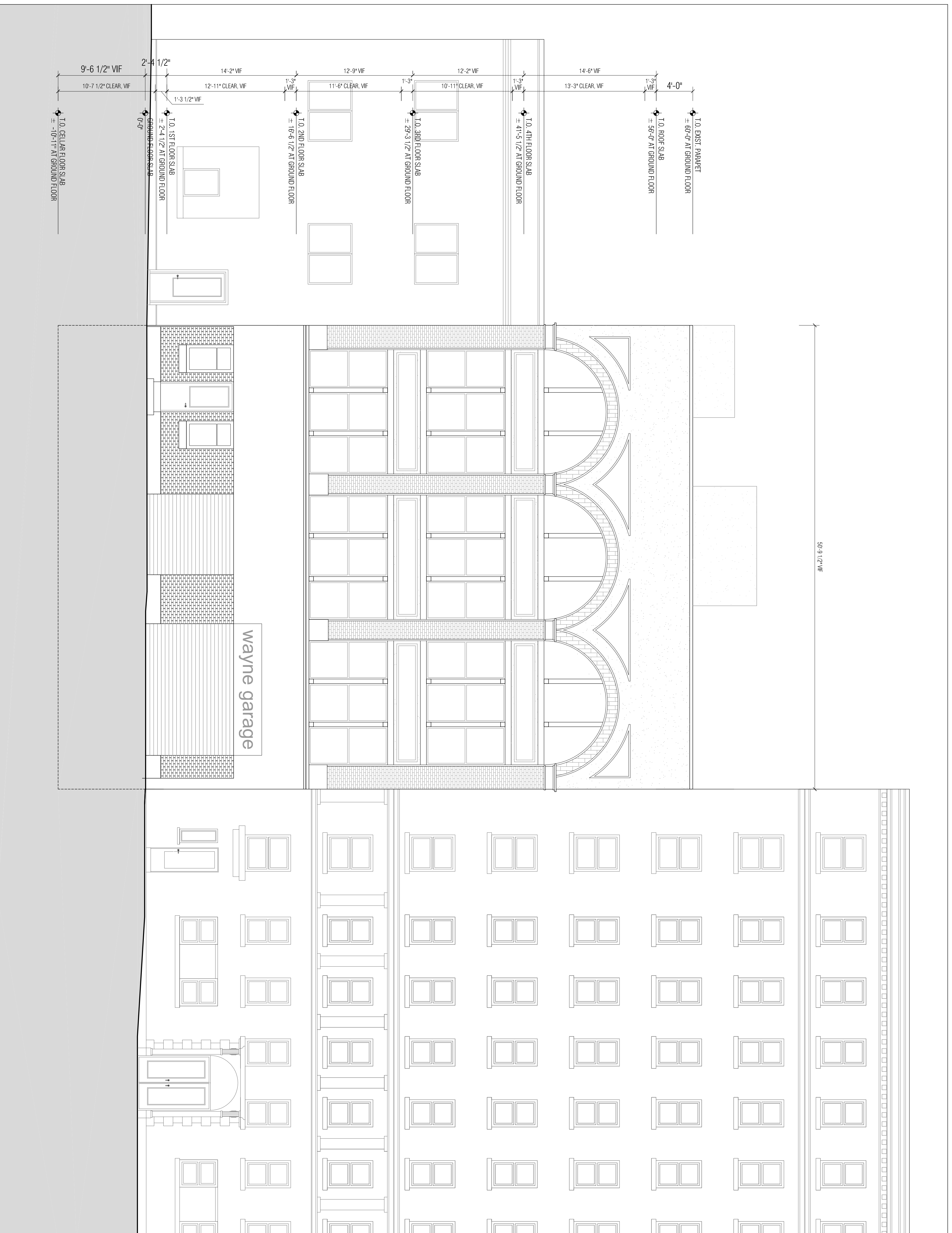

01

EXISTING FRONT ELEVATION

NUMBER	DATE	ISSUED FOR:
1	1/20/13	50 % DESIGN DEVELOPMENT SET

**111 EB2ND STREET**  
 NEW YORK, NEW YORK  
**GARAGE MANAGEMENT COMPANY**  
OWNER  
 770 LEXINGTON AVENUE, 11TH FLOOR  
 NEW YORK, NEW YORK 10065

ARCHITECT  
**DANIEL GOLDNER ARCHITECTS**  
 143 WEST 29TH STREET  
 NEW YORK, NY 10001  
 TEL: 212.268.8511  
 FAX: 212.268.1129

STRUCTURAL ENGINEER  
**WEXLER ASSOCIATES**  
 12 W32ND STREET, 8TH FLOOR  
 TEL: 212.643.1500  
 FAX: 212.643.2277  
 INFO@NWEXLER.COM

- DEMOLITION NOTES:
1. REMOVE ANY EXISTING CONDITIONS TO MEET NEW CONSTRUCTION
  2. CORRELATE DEMOLITION WITH NEW FRONT FACADE

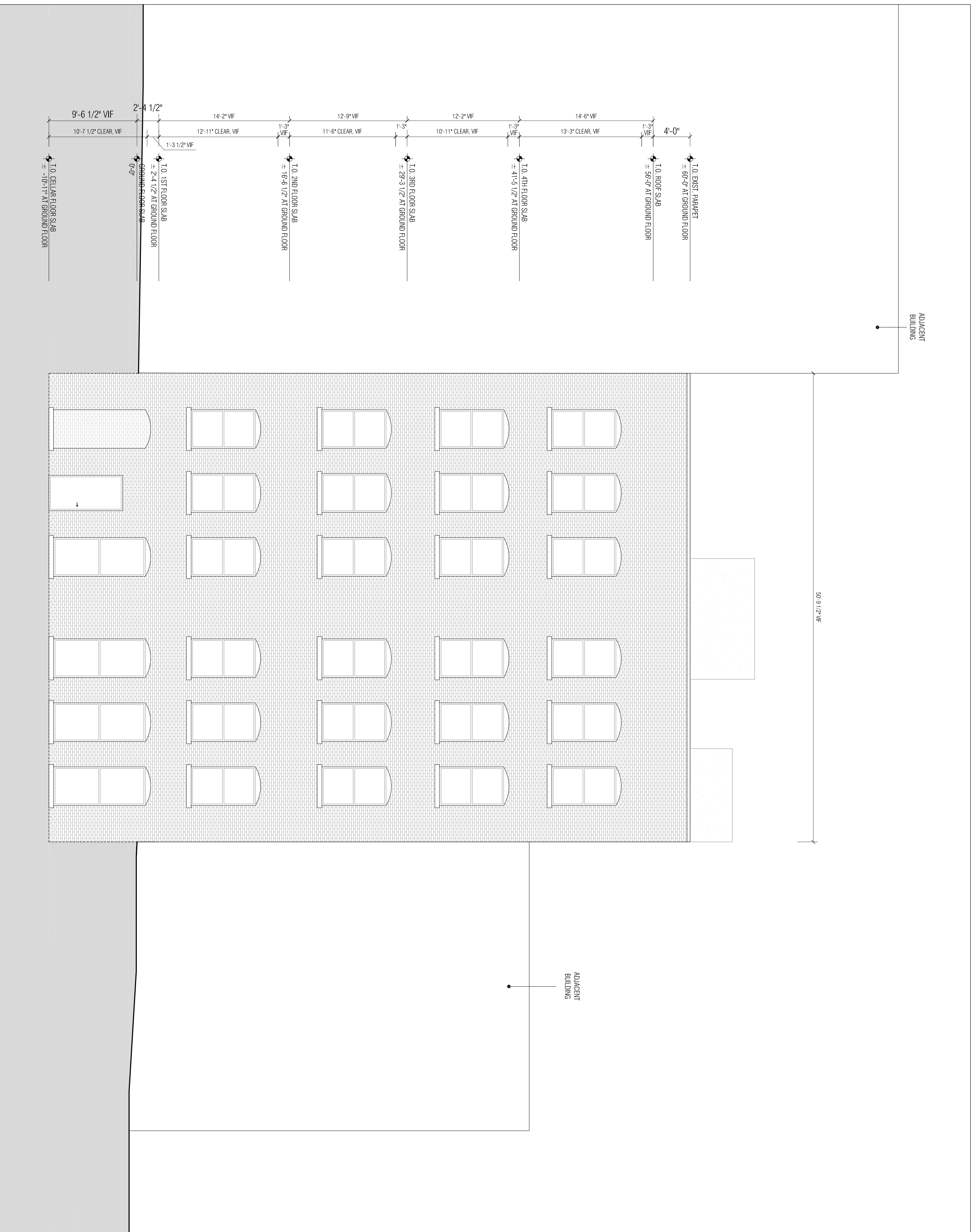

01 EXISTING REAR ELEVATION

NUMBER	DATE	ISSUED FOR:
1	12/04/12	50 % DESIGN DEVELOPMENT SET

**111 EB2ND STREET**  
 NEW YORK, NEW YORK  
**GARAGE MANAGEMENT COMPANY**  
OWNER  
 770 LEXINGTON AVENUE, 11TH FLOOR  
 NEW YORK, NEW YORK 10065

ARCHITECT  
**DANIEL GOLDNER ARCHITECTS**  
 143 WEST 29TH STREET  
 NEW YORK, NY 10001  
 TEL: 212.268.8511  
 FAX: 212.268.1129

STRUCTURAL ENGINEER  
**WEXLER ASSOCIATES**  
 12 W32ND STREET, 8TH FLOOR  
 TEL: 212.643.1500  
 FAX: 212.643.2277  
 INFO@NWEXLER.COM

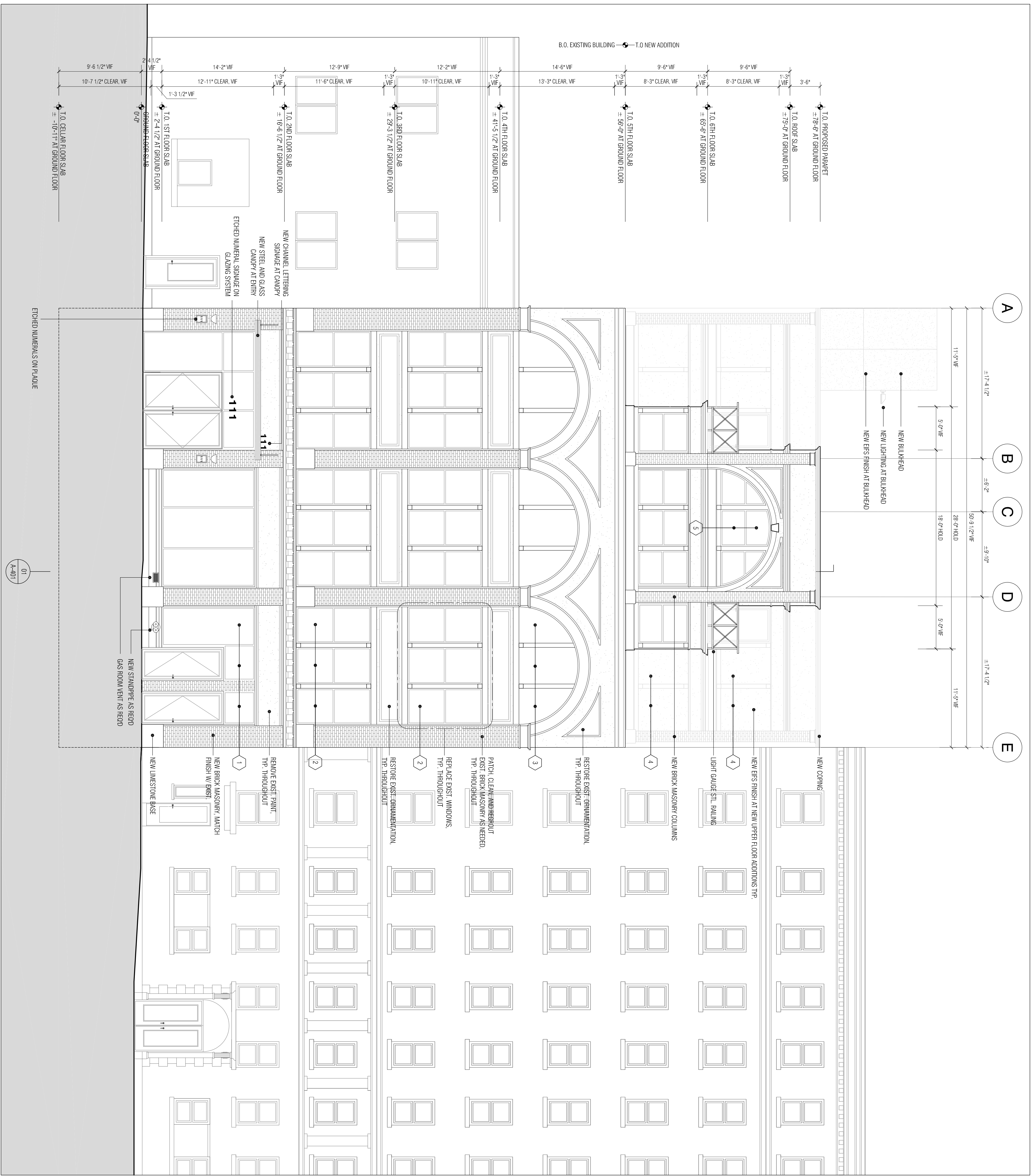

- DEMOLITION NOTES:
1. REMOVE ANY EXISTING CONDITIONS TO MEET NEW CONSTRUCTION
  2. CORRELATE DEMOLITION WITH NEW FRONT FACADE

NUMBER	DATE	ISSUED FOR:
1	1/20/13	50 % DESIGN DEVELOPMENT SET

111 EB2ND STEET  
NEW YORK, NEW YORK

GARAGE MANAGEMENT COMPANY  
770 LEXINGTON AVENUE, 11TH FLOOR  
NEW YORK, NEW YORK 10065

DANIEL GOLDNER ARCHITECTS  
143 WEST 29TH STREET  
NEW YORK, NY 10001  
TEL: 212.268.8511  
FAX: 212.268.1129

WEXLER ASSOCIATES  
12 W32ND STREET, 8TH FLOOR  
TEL: 212.643.1500  
FAX: 212.643.2277  
INFO@NWEXLER.COM

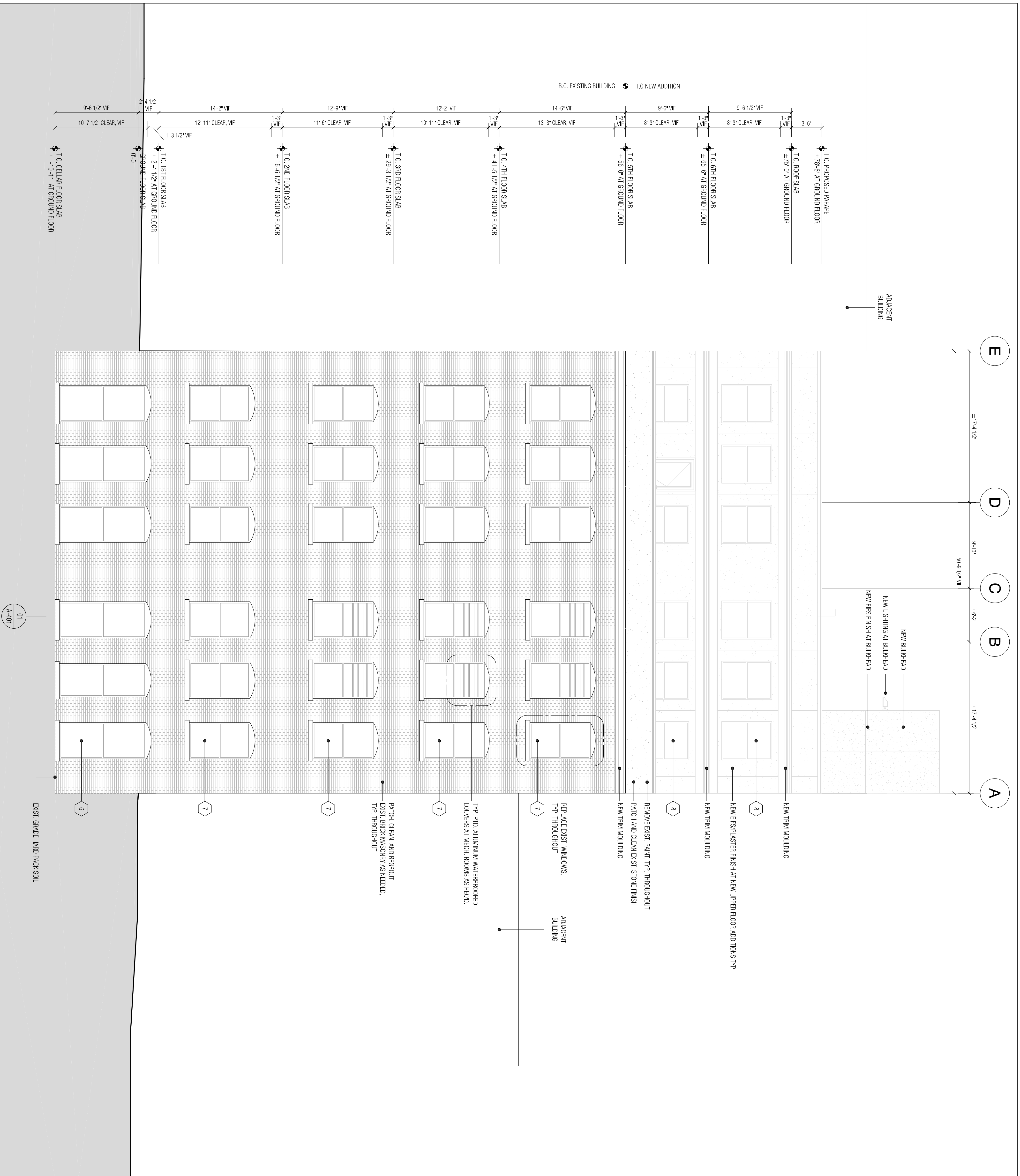

01 REAR ELEVATION

- DEMOLITION NOTES:
1. REMOVE ANY EXISTING CONDITIONS TO MEET NEW CONSTRUCTION
  2. CORRELATE DEMOLITION WITH NEW FRONT FAÇADE

NUMBER	DATE	ISSUED FOR:
1	12/04/12	50 % DESIGN DEVELOPMENT SET

111 E 22ND STREET  
 NEW YORK, NEW YORK  
 GARAGE MANAGEMENT COMPANY  
 770 LEXINGTON AVENUE, 11TH FLOOR  
 NEW YORK, NEW YORK 10065

DANIEL GOLDNER ARCHITECTS  
 143 WEST 29TH STREET  
 NEW YORK, NY 10001  
 TEL: 212.268.8511  
 FAX: 212-268-1129

WEXLER ASSOCIATES  
 12 W 32ND STREET, 8TH FLOOR  
 TEL: 212.643.1500  
 FAX: 212.643.2277  
 INFO@NWEXLER.COM

DRAWN BY: RL/G  
 SCALE: 3/16" = 1'-0"  
 TITLE: PROPOSED EXTERIOR ELEVATION  
 SHEET 12 OF 17

DRAWING NO.: A-303.01

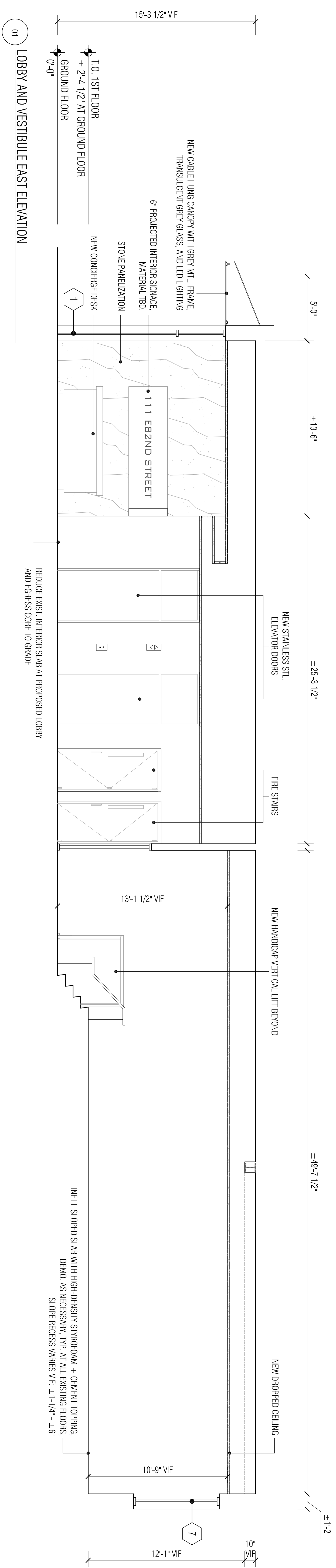

- DEMOLITION NOTES:
1. REMOVE ANY EXISTING CONDITIONS TO MEET NEW CONSTRUCTION
  2. CORRELATE DEMOLITION WITH NEW FRONT FACADE

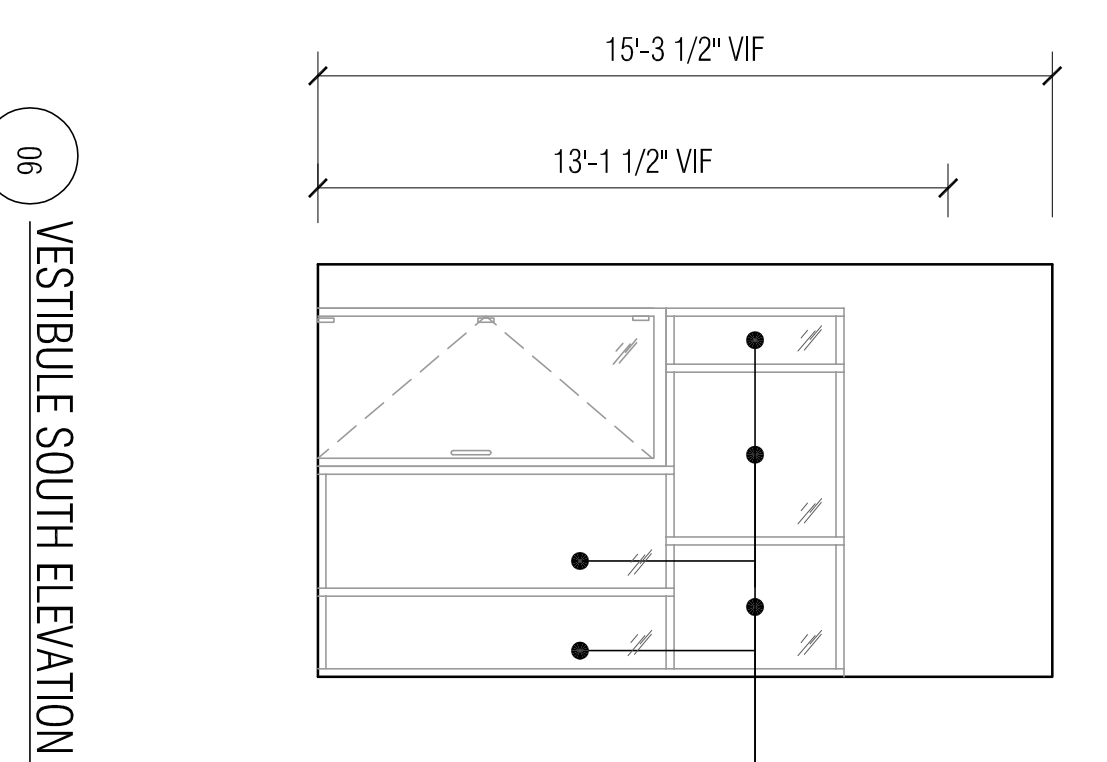
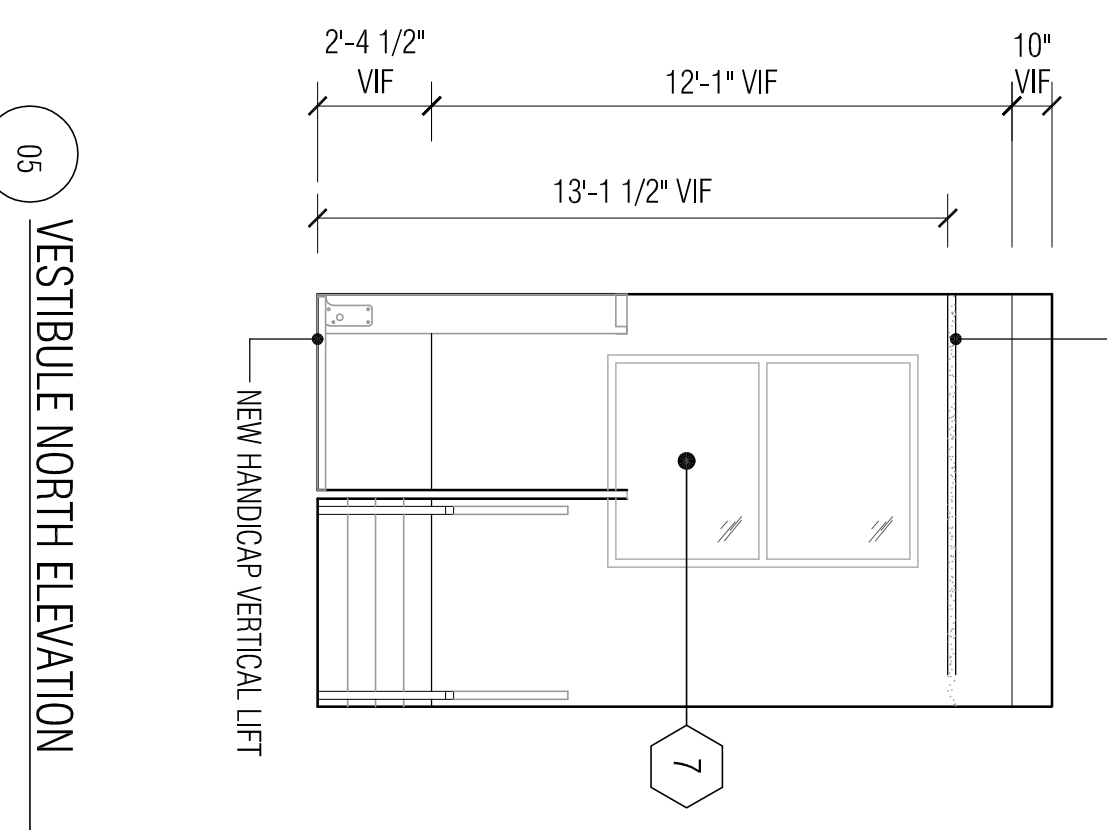
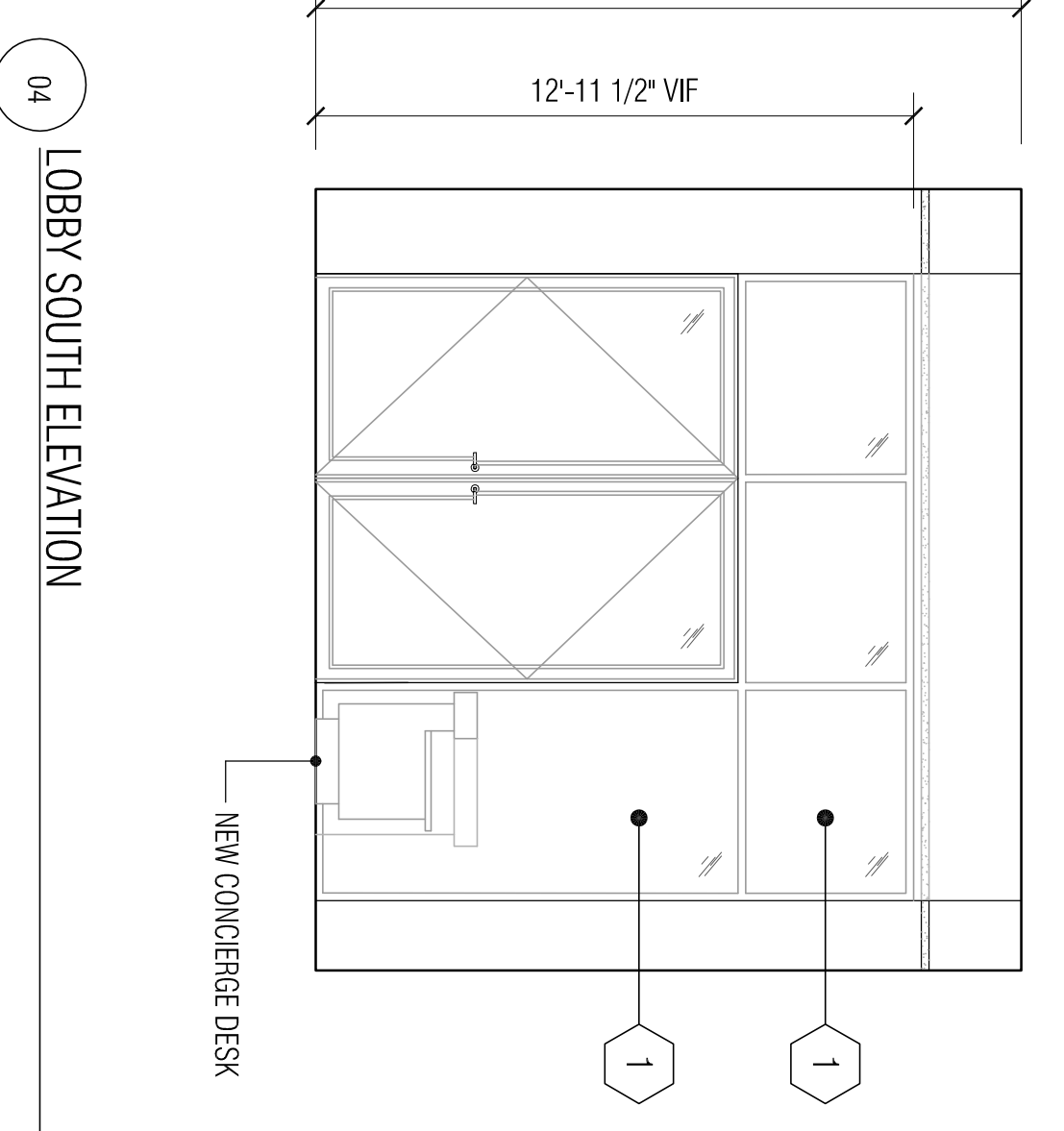
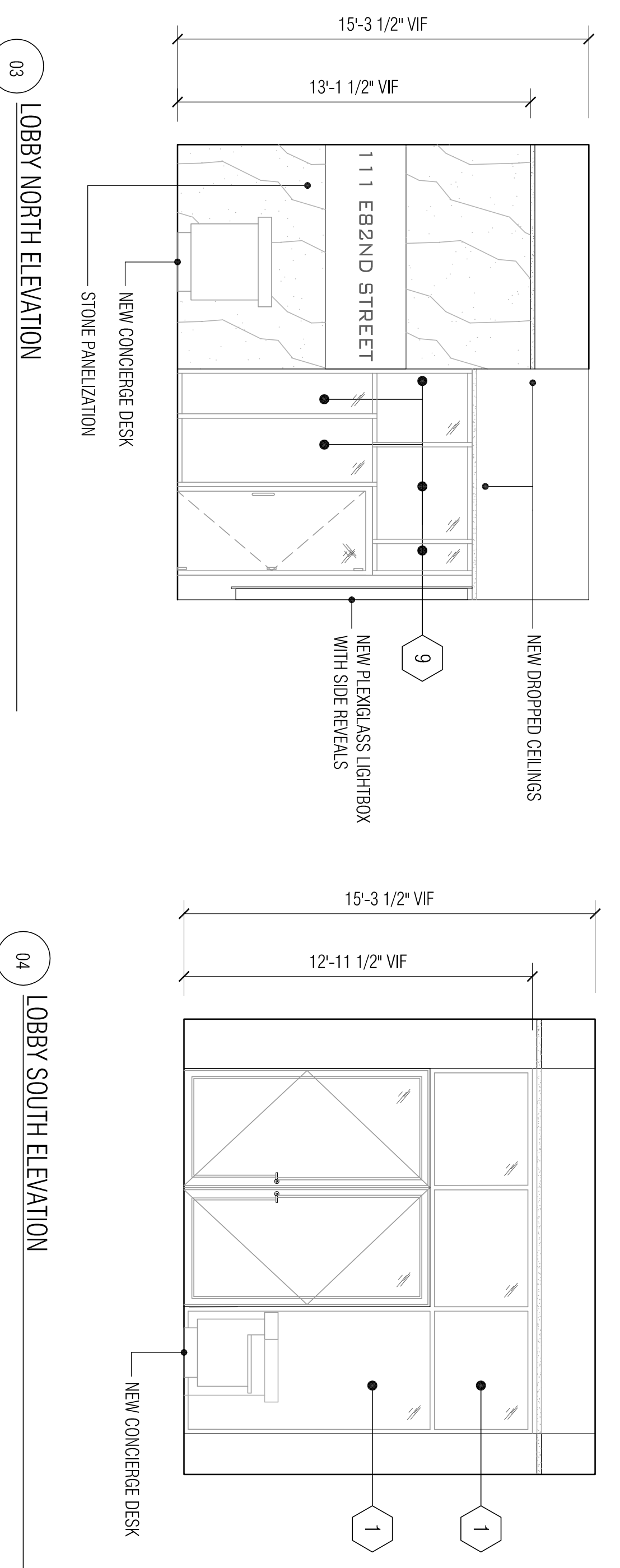
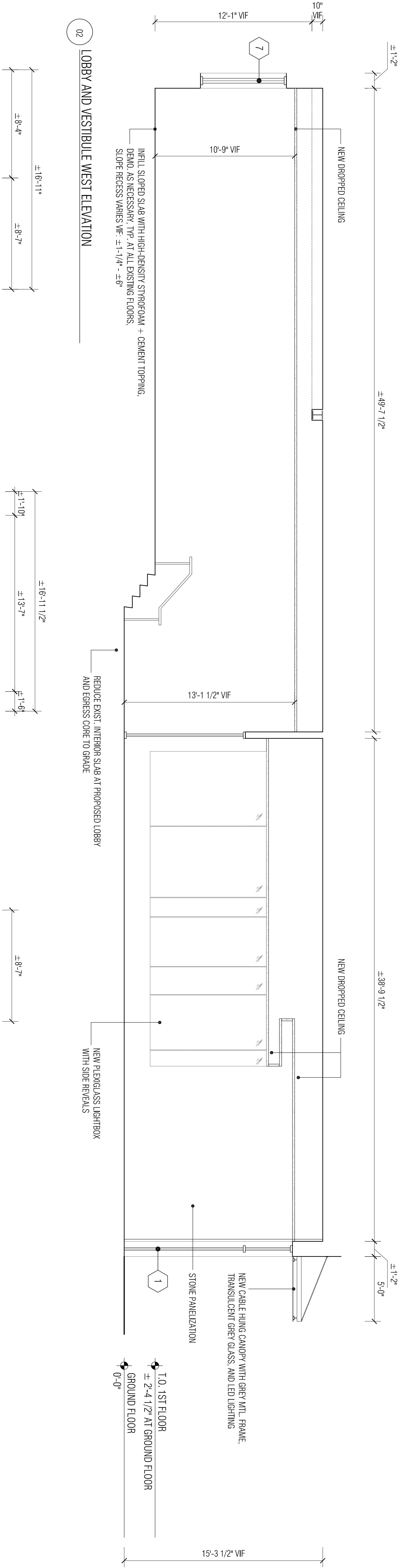

NUMBER	DATE	ISSUED FOR:
1	1/20/13	50 % DESIGN DEVELOPMENT SET

**111 EB2ND STEET**  
 NEW YORK, NEW YORK  
**GARAGE MANAGEMENT COMPANY**  
 770 LEXINGTON AVENUE, 11TH FLOOR  
 NEW YORK, NEW YORK 10065

**DANIEL GOLDNER ARCHITECTS**  
 143 WEST 29TH STREET  
 NEW YORK, NY 10001  
 TEL: 212.268.8511  
 FAX: 212.268.1129

**WEXLER ASSOCIATES**  
 12 W32ND STREET, 8TH FLOOR  
 TEL: 212.643.1500  
 FAX: 212.643.2277  
 INFO@NWEXLER.COM

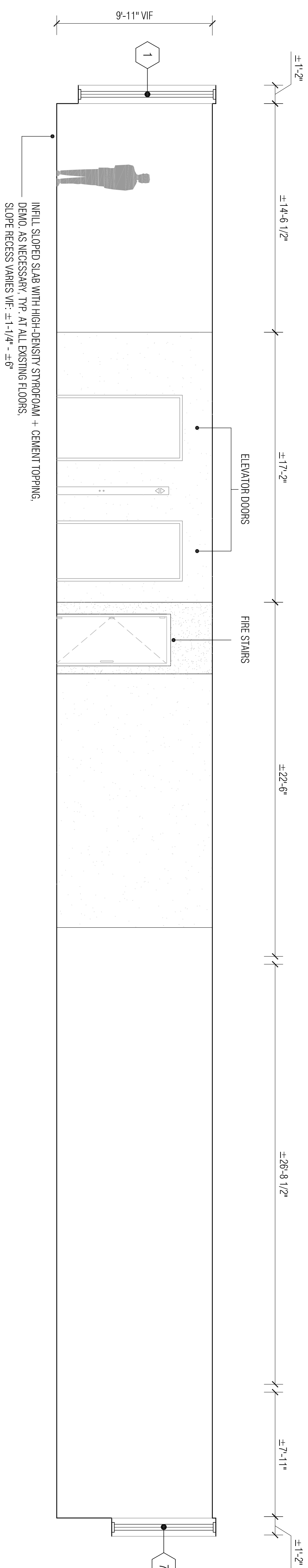

01 TYPICAL FLOOR SOUTHEAST ELEVATION

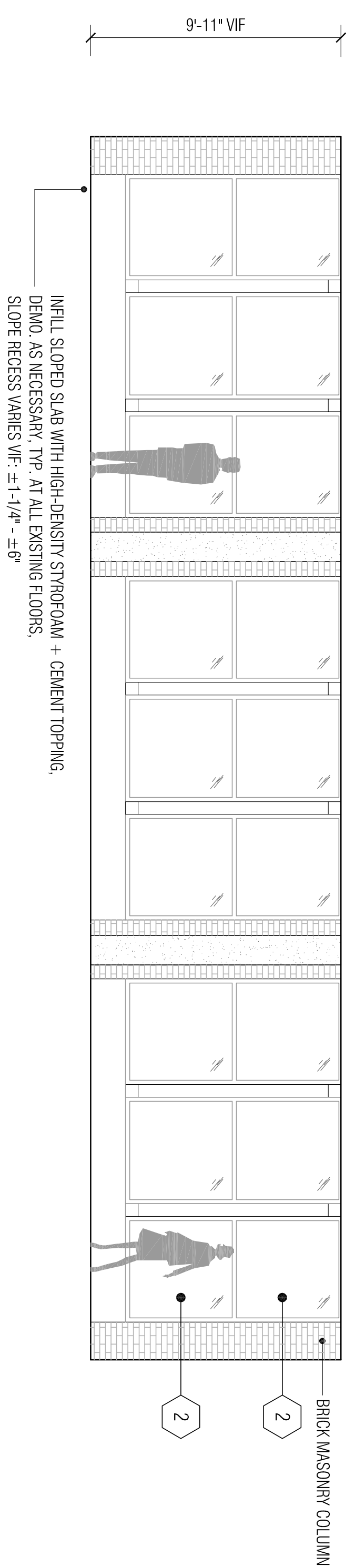
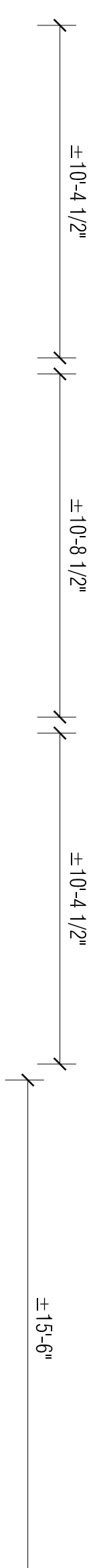

01 TYPICAL FLOOR NORTHEAST ELEVATION

- DEMOLITION NOTES:
1. REMOVE ANY EXISTING CONDITIONS TO MEET NEW CONSTRUCTION
  2. CORRELATE DEMOLITION WITH NEW FRONT FACADE

NUMBER	DATE	ISSUED FOR:
1	1/20/12	50 % DESIGN DEVELOPMENT SET

**111 EB2ND STREET**  
 NEW YORK, NEW YORK  
**GARAGE MANAGEMENT COMPANY**  
 770 LEXINGTON AVENUE, 11TH FLOOR  
 NEW YORK, NEW YORK 10065

**DANIEL GOLDNER ARCHITECTS**  
 143 WEST 29TH STREET  
 NEW YORK, NY 10001  
 TEL: 212.268.8511  
 FAX: 212-268-1129

**WEXLER ASSOCIATES**  
 12 W32ND STREET, 8TH FLOOR  
 TEL: 212.643.1500  
 FAX: 212.643.2277  
 INFO@NWEXLER.COM

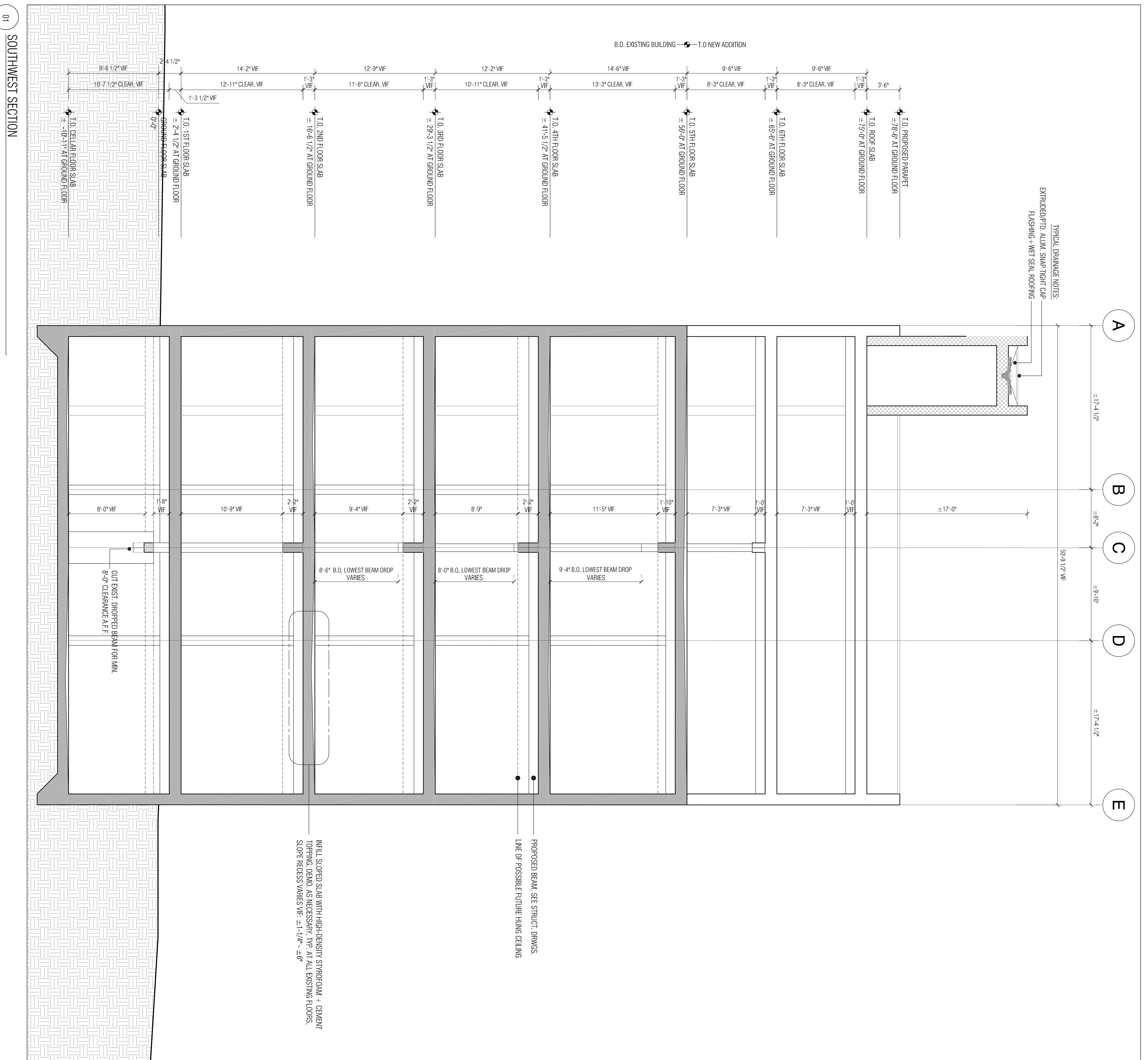

01 SOUTHWEST SECTION

**LEGEND**

	EXISTING WALL
	NEW CMU WALL
	NEW WALL

**DEMOLITION NOTES:**

- REMOVE ANY EXISTING CONDITIONS TO MEET NEW CONSTRUCTION
- CORRELATE DEMOLITION WITH NEW FRONT FACADE

NUMBER	DATE	ISSUED FOR:
1	1/20/12	50 % DESIGN DEVELOPMENT SET

**111 EBZOND STREET**  
 NEW YORK, NEW YORK  
**GARAGE MANAGEMENT COMPANY**  
 770 LEXINGTON AVENUE, 11TH FLOOR  
 NEW YORK, NEW YORK 10065

**DANIEL GOLDNER ARCHITECTS**  
 143 WEST 29TH STREET  
 NEW YORK, NY 10001  
 TEL: 212.268.8511  
 FAX: 212.268.1129

**WEXLER ASSOCIATES**  
 12 W32ND STREET, 8TH FLOOR  
 TEL: 212.643.1500  
 FAX: 212.643.2277  
 INFO@NWEXLER.COM

DRAWN BY: RLG  
 SCALE: 3/16" = 1'-0"  
 TITLE: SOUTHWEST SECTION  
 DRAWING NO.: A-400.01  
 SHEET 15 OF 17

01 SOUTHEAST SECTION

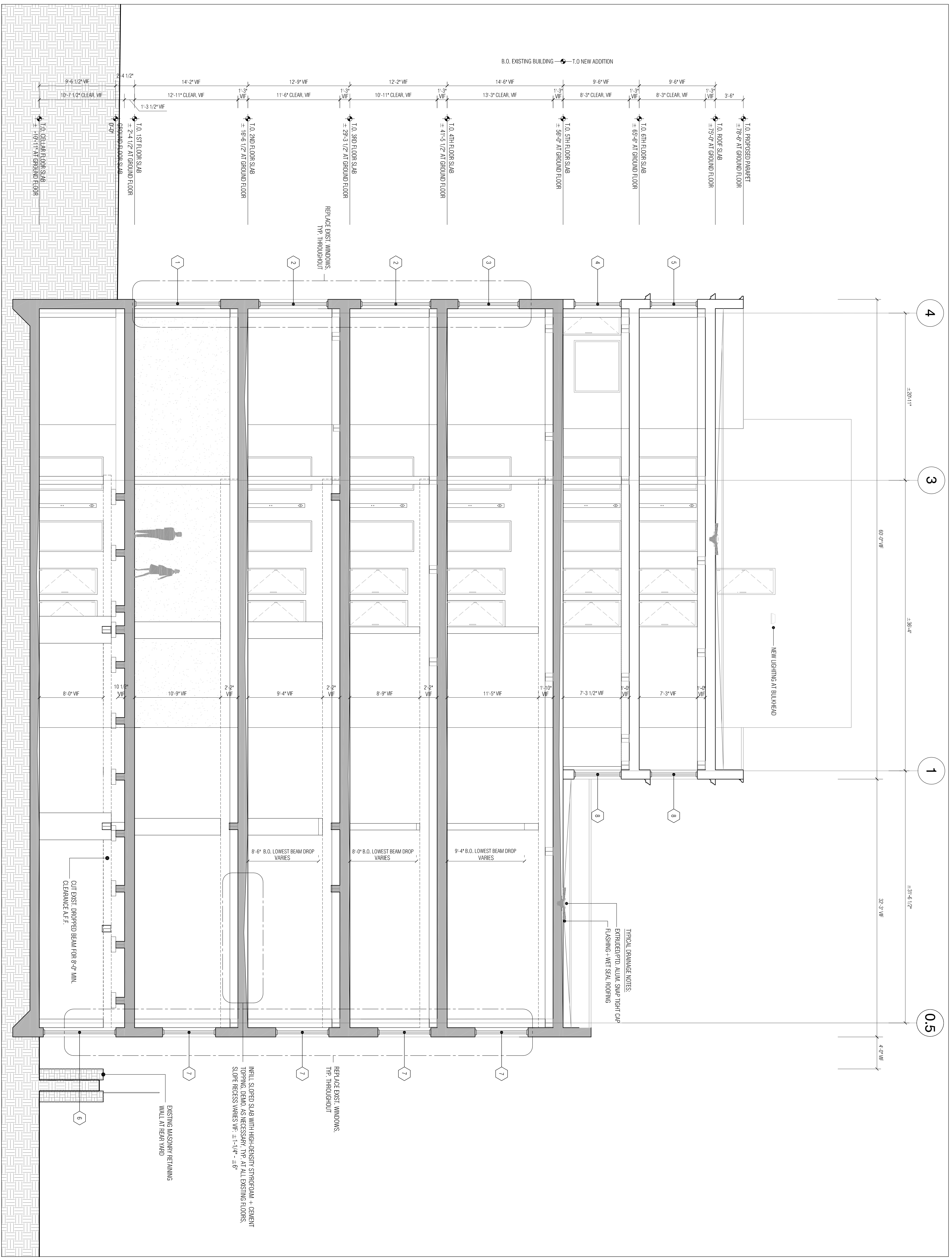

**LEGEND**

	EXISTING WALL
	NEW CMU WALL
	NEW WALL

- DEMOLITION NOTES:**
1. REMOVE ANY EXISTING CONDITIONS TO MEET NEW CONSTRUCTION
  2. CORRELATE DEMOLITION WITH NEW FRONT FACADE

NUMBER	DATE	ISSUED FOR:
1	1/20/13	50% DESIGN DEVELOPMENT SET

**111 EBZOND STREET**  
 NEW YORK, NEW YORK  
**GARAGE MANAGEMENT COMPANY**  
 770 LEXINGTON AVENUE, 11TH FLOOR  
 NEW YORK, NEW YORK 10065

**DANIEL GOLDNER ARCHITECTS**  
 143 WEST 29TH STREET  
 NEW YORK, NY 10001  
 TEL: 212.268.8511  
 FAX: 212.268.1129

**WEXLER ASSOCIATES**  
 12 W32ND STREET, 8TH FLOOR  
 TEL: 212.643.1500  
 FAX: 212.643.2277  
 INFO@NWEXLER.COM





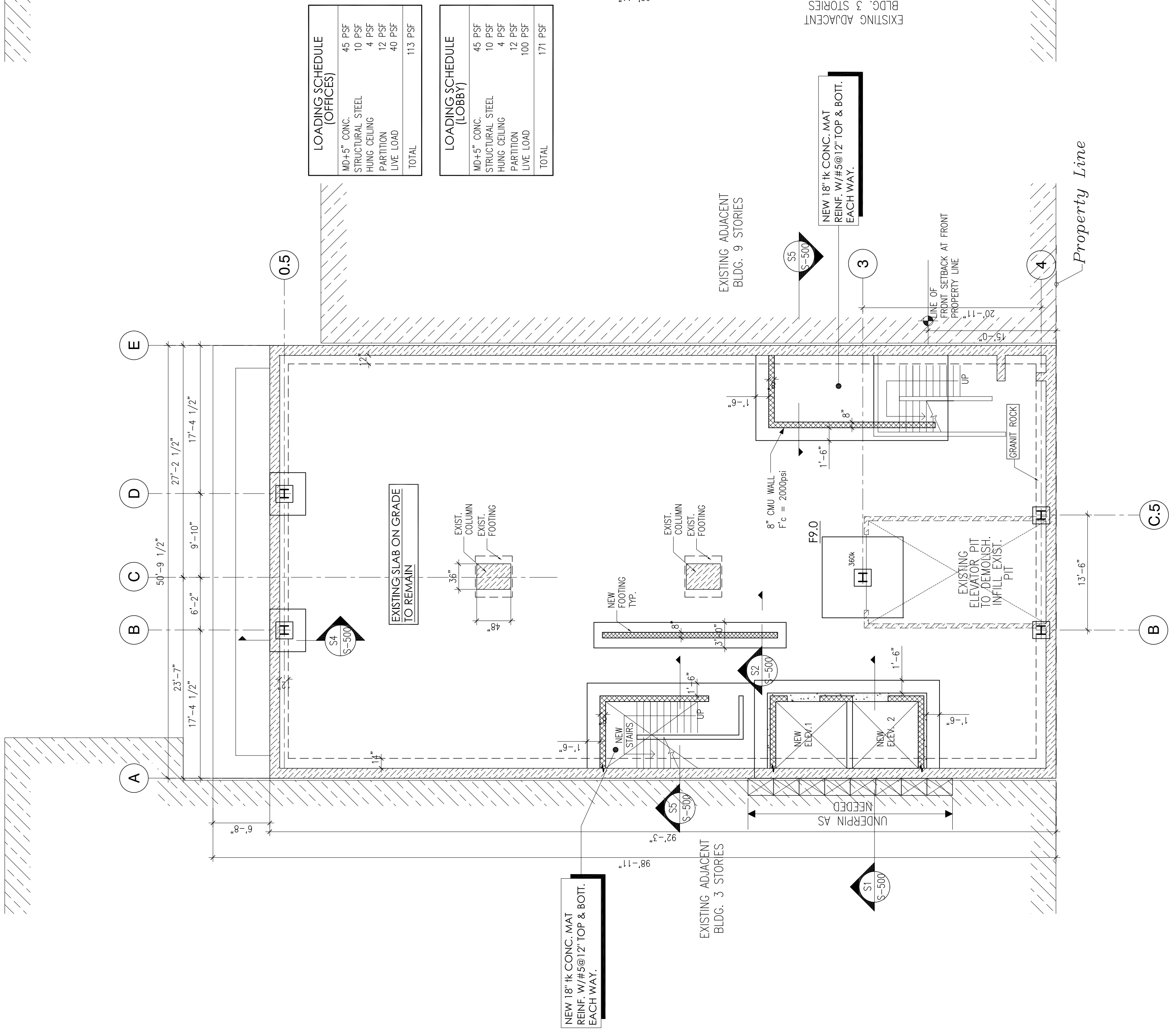

### CELLAR & FOUNDATION PLAN

SCALE: 1/8"=1'-0"

### 82ND STREET

SCALE: 1/8"=1'-0"

### FIRST FLOOR FRAMING PLAN

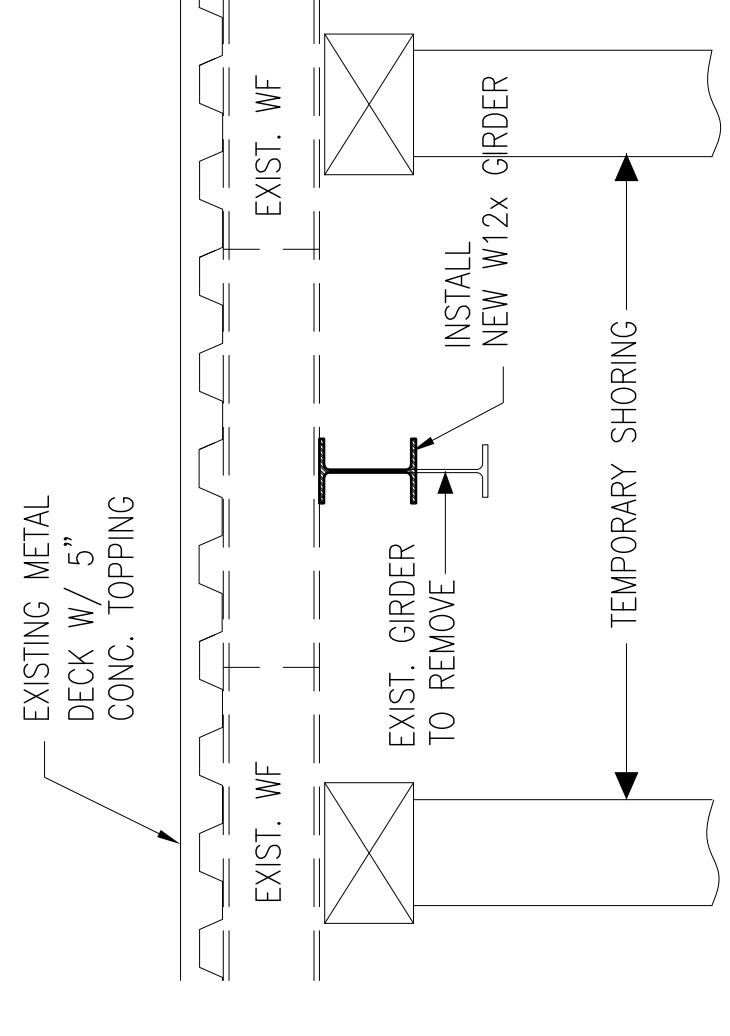
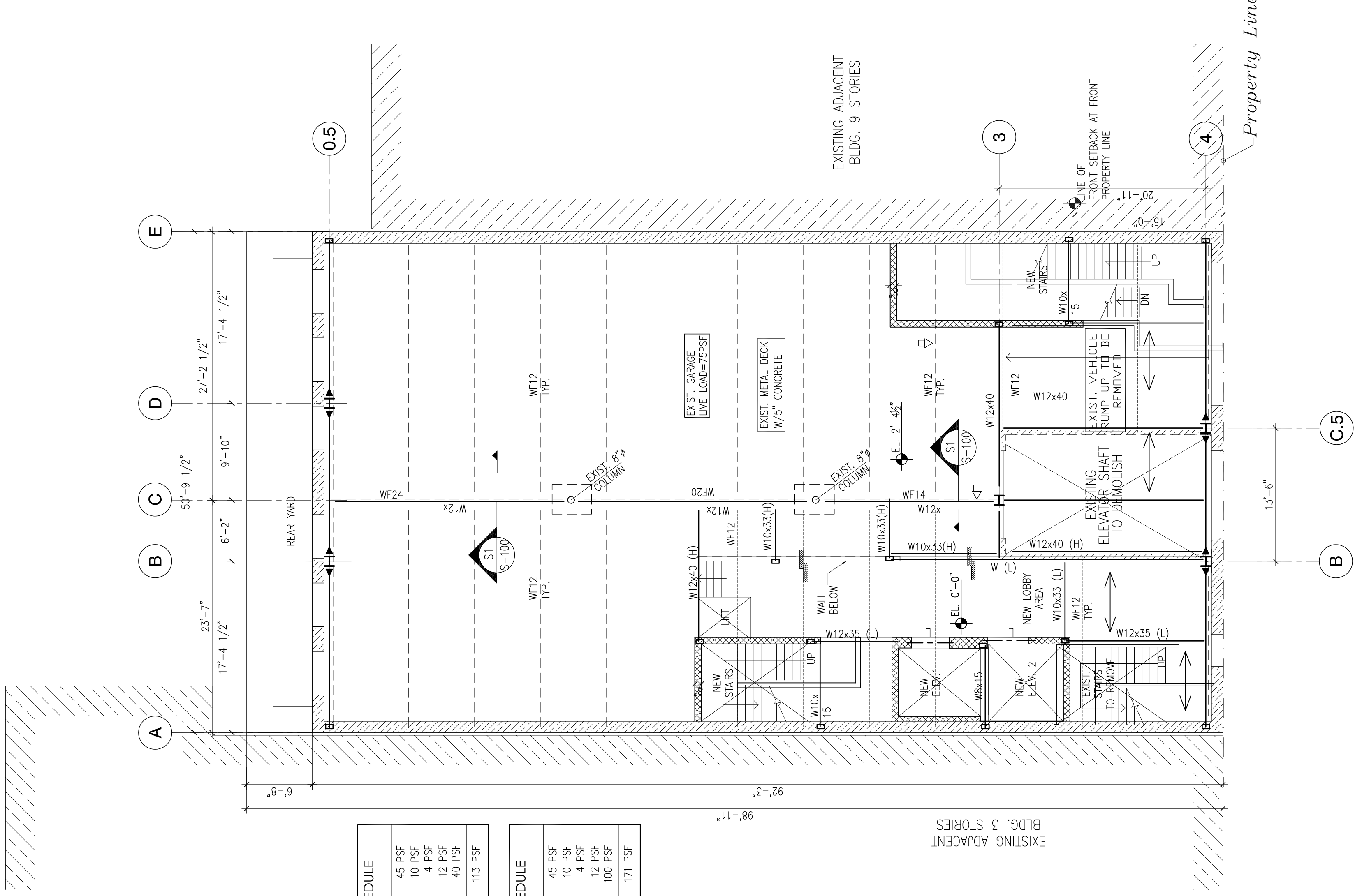

NUMBER	DATE	ISSUED FOR:
1	11-16-12	PROGRESS SET
2	12-04-12	50% DD SET

111 EB2ND STEET  
NEW YORK, NEW YORK  
OWNER  
GARAGE MANAGEMENT COMPANY  
770 LEXINGTON AVENUE, 11TH FLOOR  
NEW YORK, NEW YORK 10065

ARCHITECT  
DANIEL GOLDNER ARCHITECTS  
143 WEST 29TH STREET  
NEW YORK, NY 10001  
TEL: 212.268.8511  
FAX: 212-268-1129

STRUCTURAL ENGINEER  
WEXLER ASSOCIATES  
12 W32ND STREET, 8TH FLOOR  
TEL: 212.643.1500  
FAX: 212.643.2277  
INFO@NWEXLER.COM

### CELLAR & FOUNDATION AND FIRST FLOOR FRAMING PLAN

DRAWN BY:  
SCALE:  
TITLE:  
DRAWING NO.:  
S-100.00  
SHEET 2 OF 7

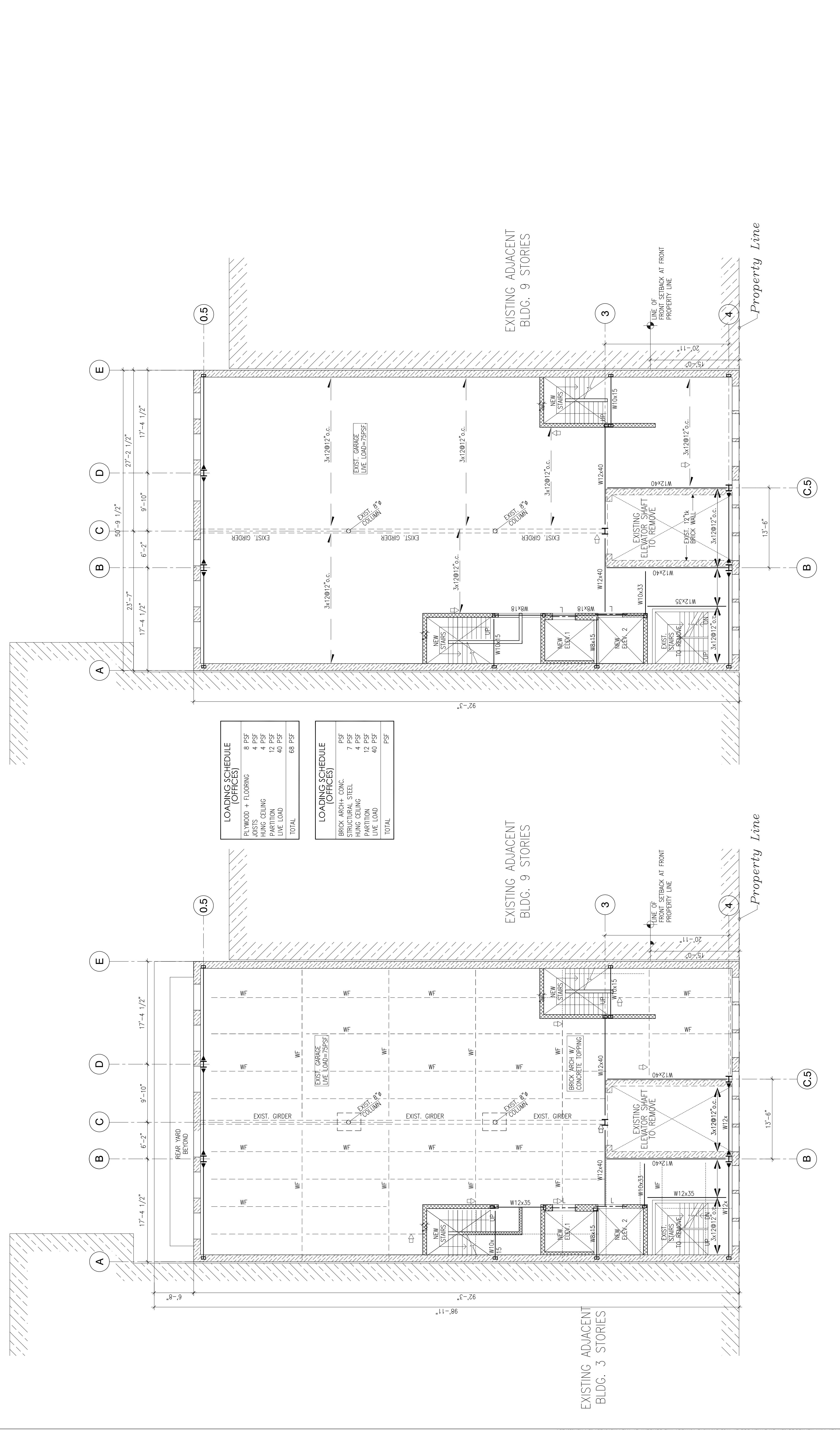

LOADING SCHEDULE (OFFICES)	
PLYWOOD + FLOORING	8 PSF
JOISTS	4 PSF
HUNG CEILING	4 PSF
PARTITION	12 PSF
LIVE LOAD	40 PSF
TOTAL	68 PSF

LOADING SCHEDULE (OFFICES)	
BRICK ARCH+ CONC.	PSF
STRUCTURAL STEEL	7 PSF
HUNG CEILING	4 PSF
PARTITION	12 PSF
LIVE LOAD	40 PSF
TOTAL	PSF

NUMBER	DATE	ISSUED FOR:
1	11-16-12	PROGRESS SET
2	12-04-12	50% DD SET

111 EB2ND STREET  
NEW YORK, NEW YORK  
GARAGE MANAGEMENT COMPANY  
770 LEXINGTON AVENUE, 11TH FLOOR  
NEW YORK, NEW YORK 10065

DANIEL GOLDNER ARCHITECTS  
143 WEST 29TH STREET  
NEW YORK, NY 10001  
TEL: 212.268.8511  
FAX: 212.268.1129

WEXLER ASSOCIATES  
12 W32ND STREET, 8TH FLOOR  
TEL: 212.643.1500  
FAX: 212.643.2277  
INFO@NWEXLER.COM

SECOND & THIRD FLOOR FRAMING PLAN

THIRD FLOOR FRAMING PLAN

82ND STREET

SECOND FLOOR FRAMING PLAN

- SCALE: 1/8"=1'-0"
- NOTES**
- TOP OF EXIST. CONC. SLAB ELEV. = 28'-8"
  - EXISTING GARAGE LIVE LOAD= 75 PSF PER CERTIFICATE OF OCCUPANCY BY BUREAU OF BUILDINGS BOURGHOUGH OF MANHATTAN, CITY OF NEW YORK DATED APRIL 1, 1921.
- LEGEND**
- INDICATES EXISTING WALL.
  - INDICATES EXISTING BEAM.
  - INDICATES NEW STEEL.
  - INDICATES NEW WOOD JOIST.
  - INDICATES MOMENT CONNECTION.
  - INDICATES STRUCTURE TO BE REMOVED.
  - TEMPORARY SHORING.
  - INDICATES NEW WALL.
  - INDICATES EXISTING WOOD JOIST.

- SCALE: 1/8"=1'-0"
- NOTES**
- TOP OF EXIST. CONC. SLAB ELEV. = 16'-2"
  - EXISTING GARAGE LIVE LOAD= 75 PSF PER CERTIFICATE OF OCCUPANCY BY BUREAU OF BUILDINGS BOURGHOUGH OF MANHATTAN, CITY OF NEW YORK DATED APRIL 1, 1921.
- LEGEND**
- INDICATES EXISTING WALL.
  - INDICATES EXISTING BEAM.
  - INDICATES NEW STEEL.
  - INDICATES NEW WOOD JOIST.
  - INDICATES MOMENT CONNECTION.
  - INDICATES STRUCTURE TO BE REMOVED.
  - TEMPORARY SHORING.
  - INDICATES NEW WALL.
  - INDICATES EXISTING WOOD JOIST.

- SCALE: 1/8"=1'-0"
- NOTES**
- TOP OF EXIST. CONC. SLAB ELEV. = 28'-8"
  - EXISTING GARAGE LIVE LOAD= 75 PSF PER CERTIFICATE OF OCCUPANCY BY BUREAU OF BUILDINGS BOURGHOUGH OF MANHATTAN, CITY OF NEW YORK DATED APRIL 1, 1921.
- LEGEND**
- INDICATES EXISTING WALL.
  - INDICATES EXISTING BEAM.
  - INDICATES NEW STEEL.
  - INDICATES NEW WOOD JOIST.
  - INDICATES MOMENT CONNECTION.
  - INDICATES STRUCTURE TO BE REMOVED.
  - TEMPORARY SHORING.
  - INDICATES NEW WALL.
  - INDICATES EXISTING WOOD JOIST.



LOADING SCHEDULE (OFFICES)	
PLYWOOD + FLOORING	8 PSF
CEILING	4 PSF
HANGING CEILING	4 PSF
PARTITION	12 PSF
LIVE LOAD	40 PSF
TOTAL	68 PSF

LOADING SCHEDULE (ROOF)	
PLYWOOD	3 PSF
JOISTS	4 PSF
HANGING CEILING	4 PSF
INSULATION + ROOFING	12 PSF
LIVE LOAD	60 PSF
TOTAL	83 PSF

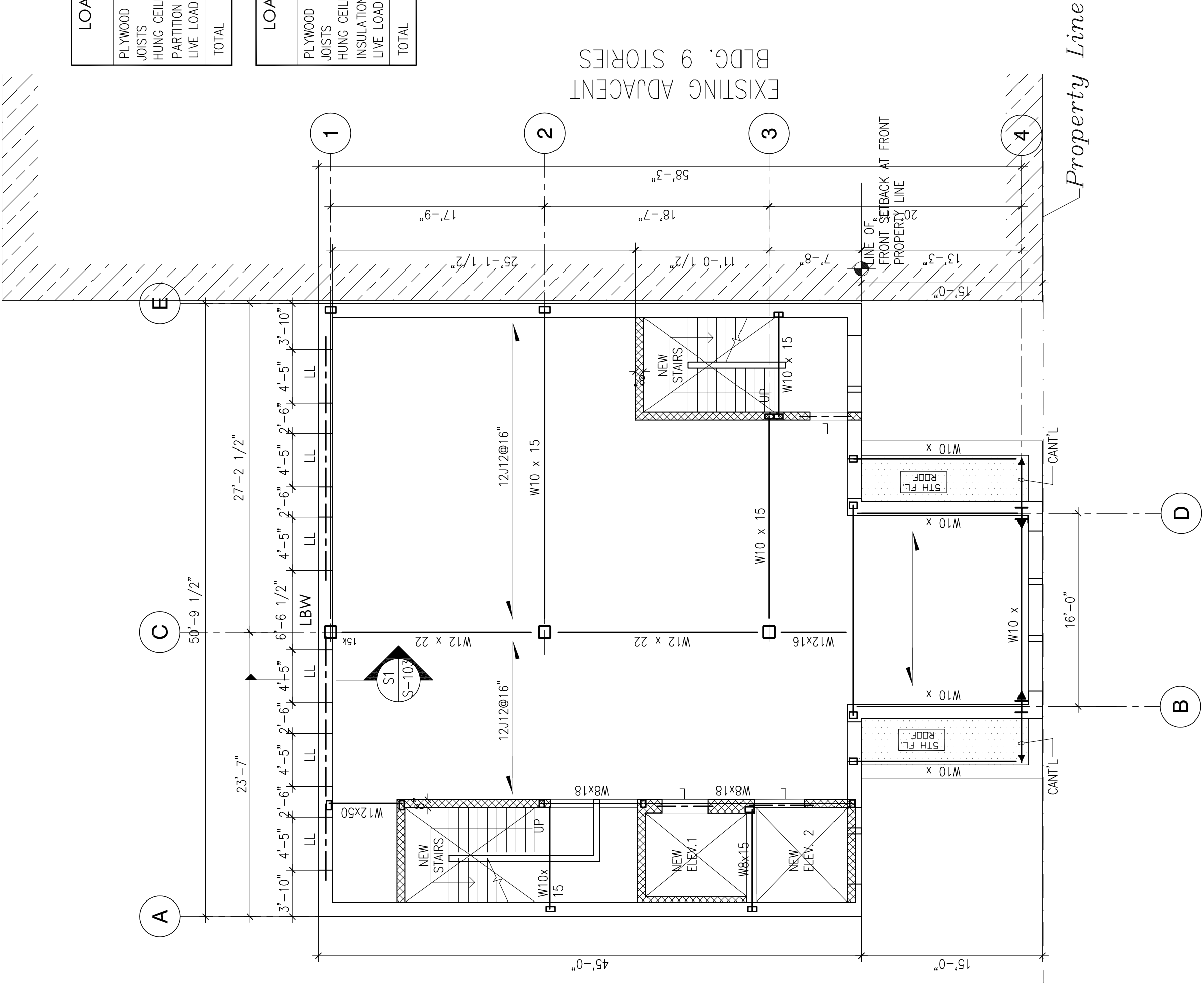

### NEW SIXTH FLOOR FRAMING PLAN

SCALE: 1/8"=1'-0"

#### NOTES

1. TOP OF EXIST. CONC. SLAB ELEV. = 64'-6"

#### LEGEND

1. INDICATES 8" CMU WALL.
2. INDICATES NEW STEEL.
3. INDICATES NEW LIGHT GAGE STEEL JOIST.
4. INDICATES MOMENT CONNECTION.
5. INDICATES COLUMN START AT THIS FLOOR.
6. INDICATES COLUMN ENDS AT THIS FLOOR.
7. LBW INDICATES LT. GA. STUD BEARING WALL.

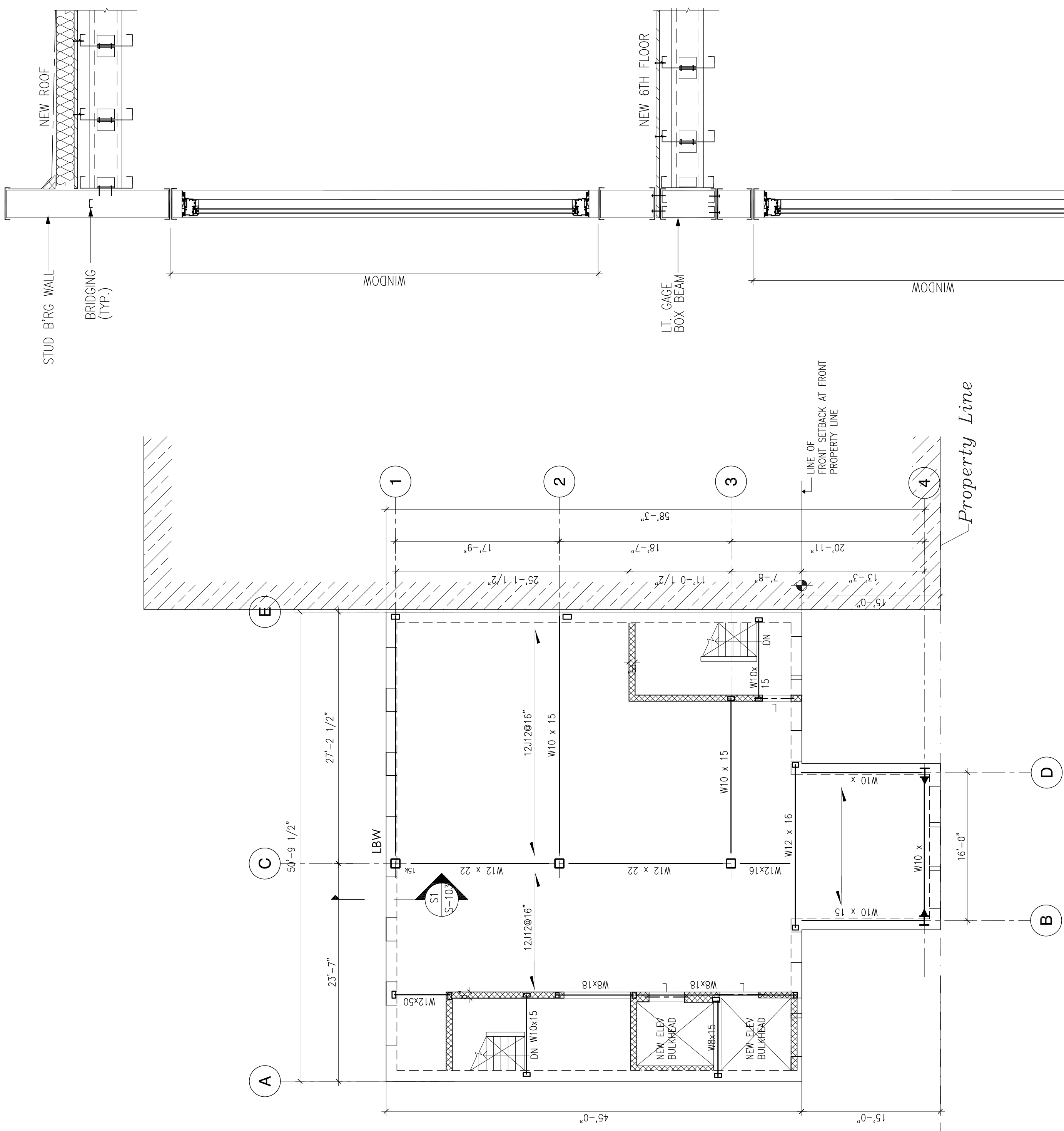

### NEW ROOF FRAMING PLAN

SCALE: 1/8"=1'-0"

#### NOTES

1. TOP OF EXIST. CONC. SLAB ELEV. = 75'-0"

#### LEGEND

1. INDICATES 8" CMU WALL.
2. INDICATES NEW STEEL.
3. INDICATES NEW LIGHT GAGE STEEL JOIST.
4. INDICATES MOMENT CONNECTION.
5. INDICATES COLUMN START AT THIS FLOOR.
6. INDICATES COLUMN ENDS AT THIS FLOOR.
7. LBW INDICATES LT. GA. STUD BEARING WALL AND LATERAL BRACE.

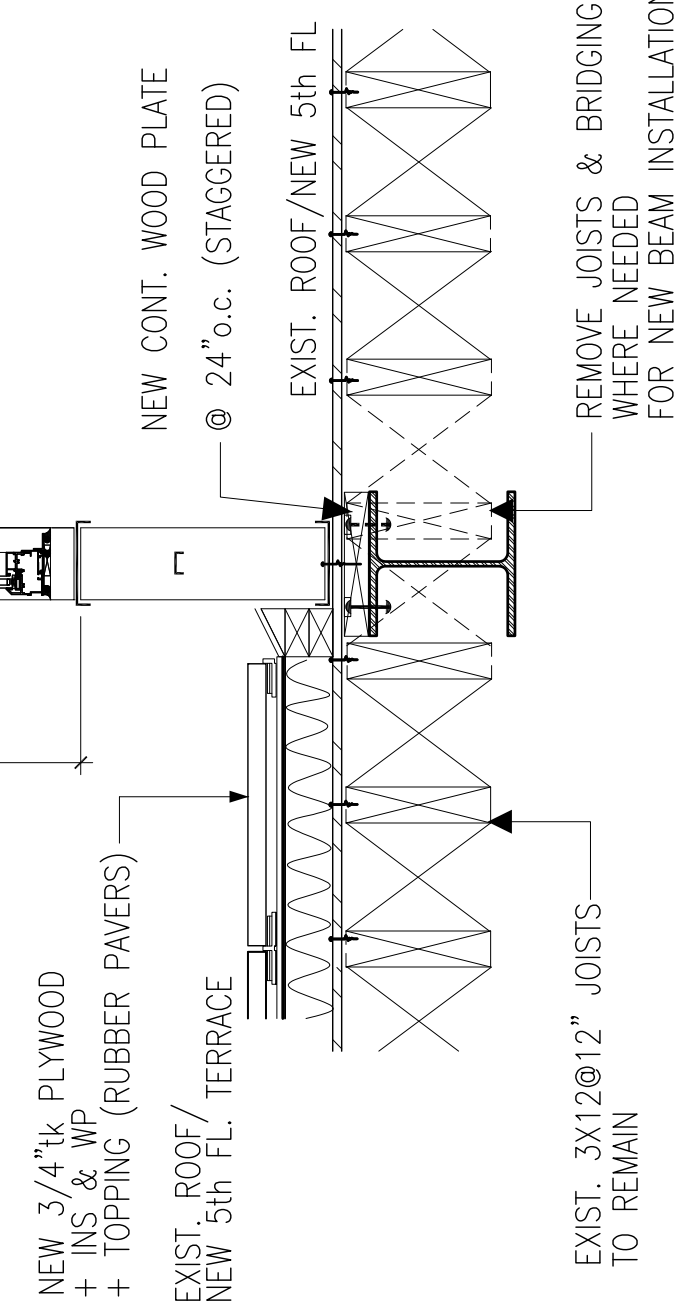
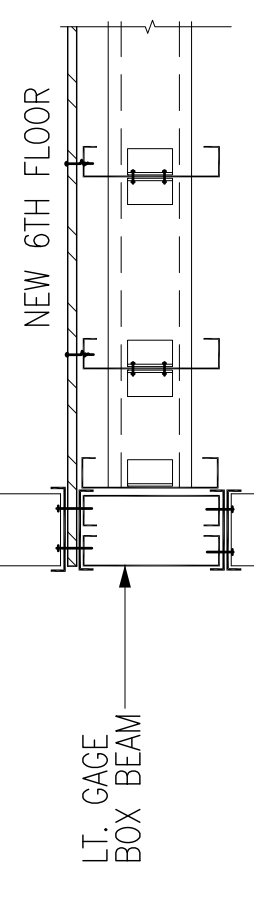
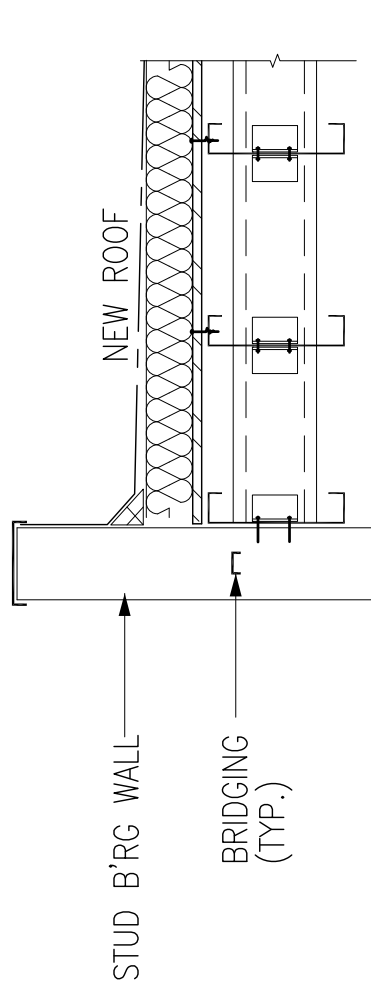

### SECTION S1

SCALE: 1/2"=1'-0"

DRAWN BY:  
SCALE:  
TITLE:

### SIXTH & ROOF FLOOR FRAMING PLAN

DRAWING NO.:  
S-103.00  
SHEET 5 OF 7

NUMBER	DATE	ISSUED FOR:
1	11-16-12	PROGRESS SET
2	12-04-12	50% DD SET

111 EB2ND STEET  
NEW YORK, NEW YORK  
OWNER  
GARAGE MANAGEMENT COMPANY  
770 LEXINGTON AVENUE, 11TH FLOOR  
NEW YORK, NEW YORK 10065

DANIEL GOLDNER ARCHITECTS  
143 WEST 29TH STREET  
NEW YORK, NY 10001  
TEL: 212.268.8511  
FAX: 212-268-1129

WEXLER ASSOCIATES  
12 W32ND STREET, 8TH FLOOR  
TEL: 212.643.1500  
FAX: 212.643.2277  
INFO@NWEXLER.COM



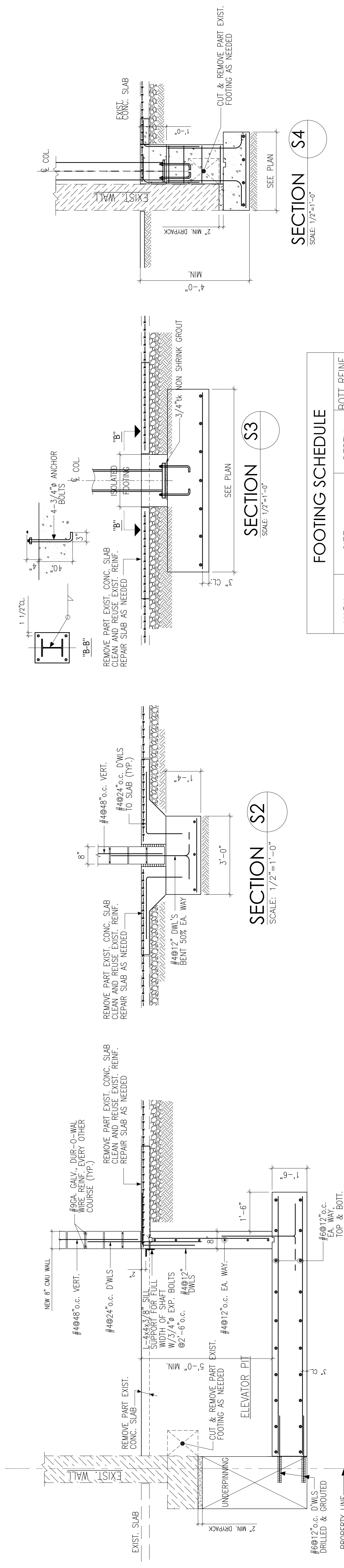

**SECTION S1 @ NEW ELEVATOR PIT**  
SCALE: 1/2"=1'-0"

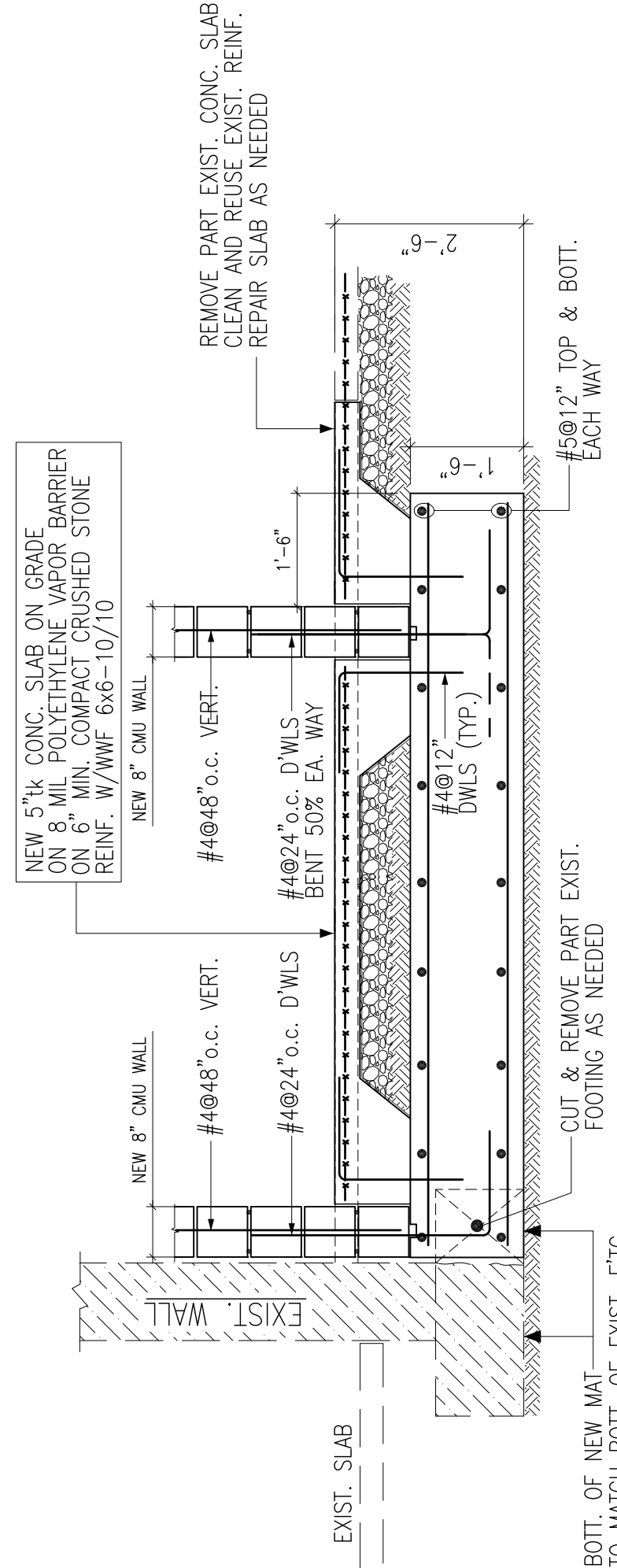

**SECTION S5 @ NEW STAIRS**  
SCALE: 1/2"=1'-0"

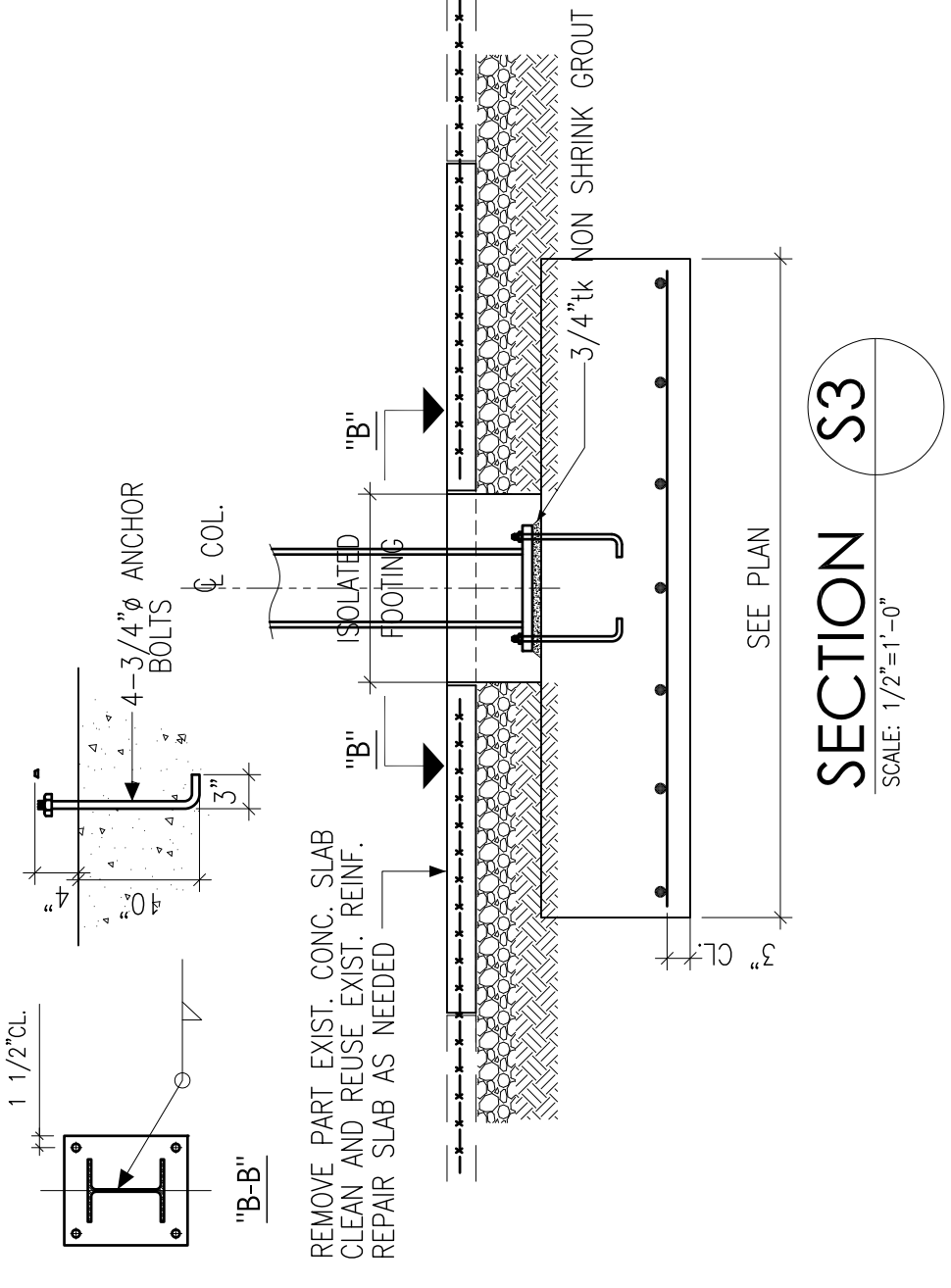

**SECTION S3**  
SCALE: 1/2"=1'-0"

FOOTING SCHEDULE				
MARK	SIZE	DEPTH	BOTT. REINF. EA. WAY	BOTT. REINF. EA. WAY
F9.0	9'-0" x 9'-0"	25"	10#6	10#6
F8.5	8'-6" x 8'-6"	24"	9#6	9#6

SOIL BEARING CAPACITY = 2 TSF.

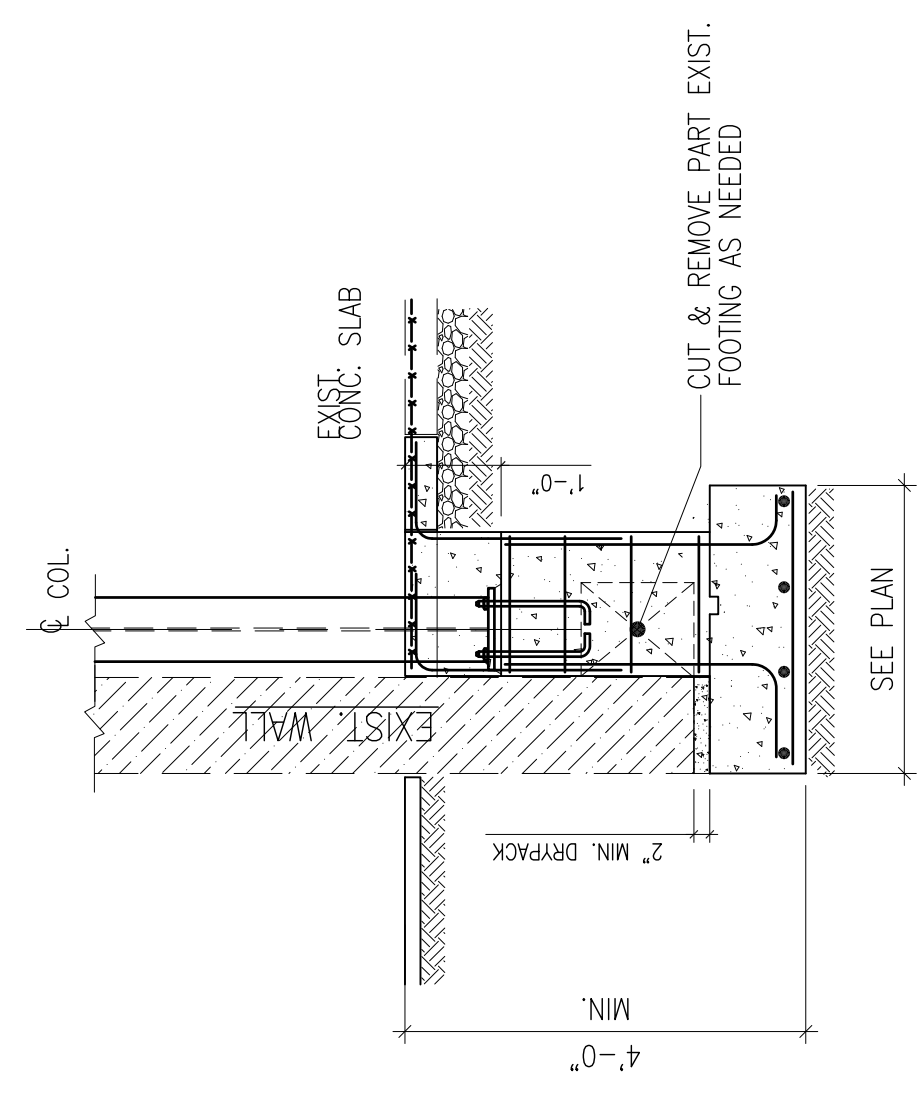

**SECTION S4**  
SCALE: 1/2"=1'-0"

NUMBER	DATE	ISSUED FOR:
1	11-16-12	PROGRESS SET
2	12-04-12	50% DD SET

111 EB2ND STEET  
NEW YORK, NEW YORK  
OWNER  
GARAGE MANAGEMENT COMPANY  
770 LEXINGTON AVENUE, 11TH FLOOR  
NEW YORK, NEW YORK 10065

ARCHITECT  
DANIEL GOLDNER ARCHITECTS  
143 WEST 29TH STREET  
NEW YORK, NY 10001  
TEL: 212.268.8511  
FAX: 212-268-1129

STRUCTURAL ENGINEER  
WEXLER ASSOCIATES  
12 W32ND STREET, 8TH FLOOR  
TEL: 212.643.1500  
FAX: 212.643.2277  
INFO@NWEXLER.COM

FOUNDATION SECTIONS  
AND DETAILS

DRAWN BY:  
SCALE:  
TITLE:  
DRAWING NO.:  
S-500.00  
SHEET 7 OF 7