

2000

Argentia Road

MISSISSAUGA, ON



FOR LEASE



Chris Burans*
Senior Vice President
+1 416 620 2866
chris.burans@colliers.com

Noel Cardy
Sales Representative
+1 416 620 2364
noel.cardy@colliers.com

Adam Dauphinee**
Senior Vice President, LEED, AP
+1 416 620 2872
adam.dauphinee@colliers.com

Anmol Dhalla*
Sales Representative
+1 647 255 2559
anmol.dhalla@colliers.com

2000

ARGENTIA ROAD, MISSISSAUGA

Featuring five BOMA Best Certified buildings, 2000 Argentia Road offers beautifully landscaped grounds, EV charging stations, plenty of parking as well as proximity to a number of highways, retailers and dining options.

Total Building Area	275,601 SF
Zoning	E1
Parking	3:1,000 ratio
Number of Buildings	5
Net Rent	\$17.95 PSF
Additional Rent	\$17.68 PSF



5-minute drive to Meadowvale GO station

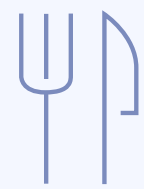

On-site café and deli

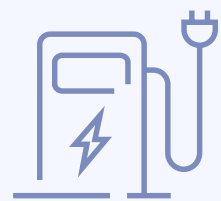

Electric vehicle charging stations



Adjacent to Mullet Creek Park offering access to plenty of greenspace



AVAILABLE SUITES & FLOOR PLANS

CLICK ON SUITE TO
VIEW FLOOR PLAN

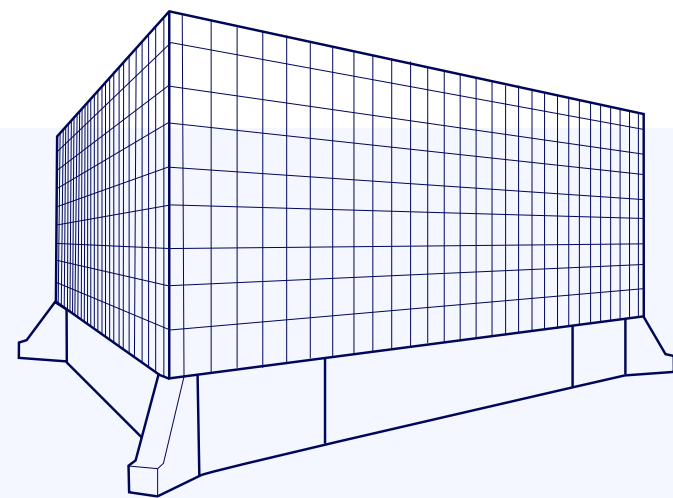

Plaza 1

2000 ARGENTIA RD

Suite	Space	Available
105	320 SF	Immediate

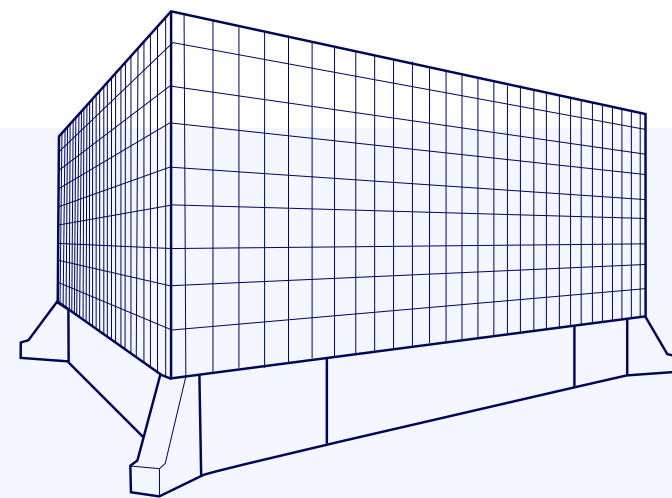

Plaza 2

2000 ARGENTIA RD

Suite	Space	Available
103	2,354	Immediate
107	1,919	April 1, 2025
300	9,847	Immediate
320	3,358	Immediate

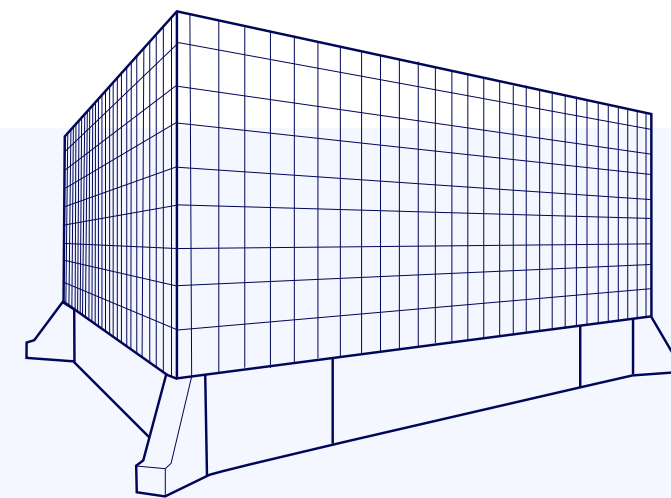

Plaza 3

2000 ARGENTIA RD

Suite	Space	Available
300	4,606	September 2025
301	4,391	Immediate
303	3,145	September 2025
300/303	7,750	September 2025

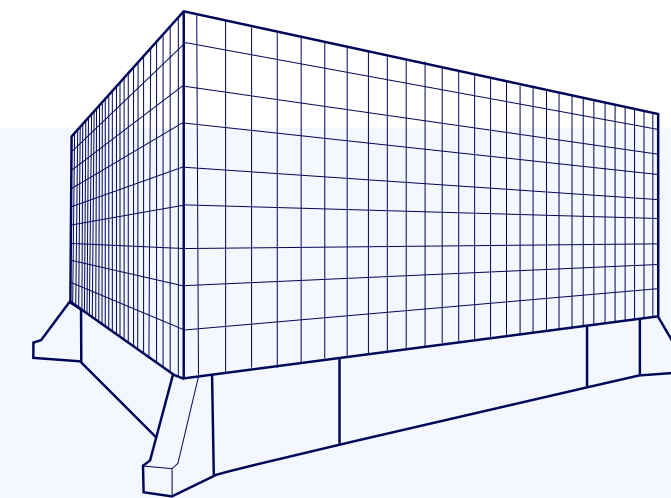

Plaza 4

2000 ARGENTIA RD

Suite	Space	Available
110	3,491	Immediate

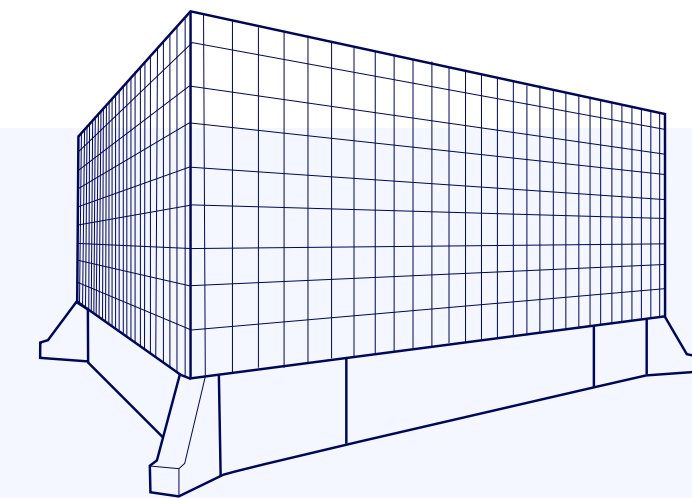

Plaza 5

2000 ARGENTIA RD

Suite	Space	Available
100	9,414	Immediate
200	13,388	Immediate
406	2,594	November 2025

Plaza One

SUITE 105

320 SF

- Small open space just off of the lobby
- Glass frontage and entrance

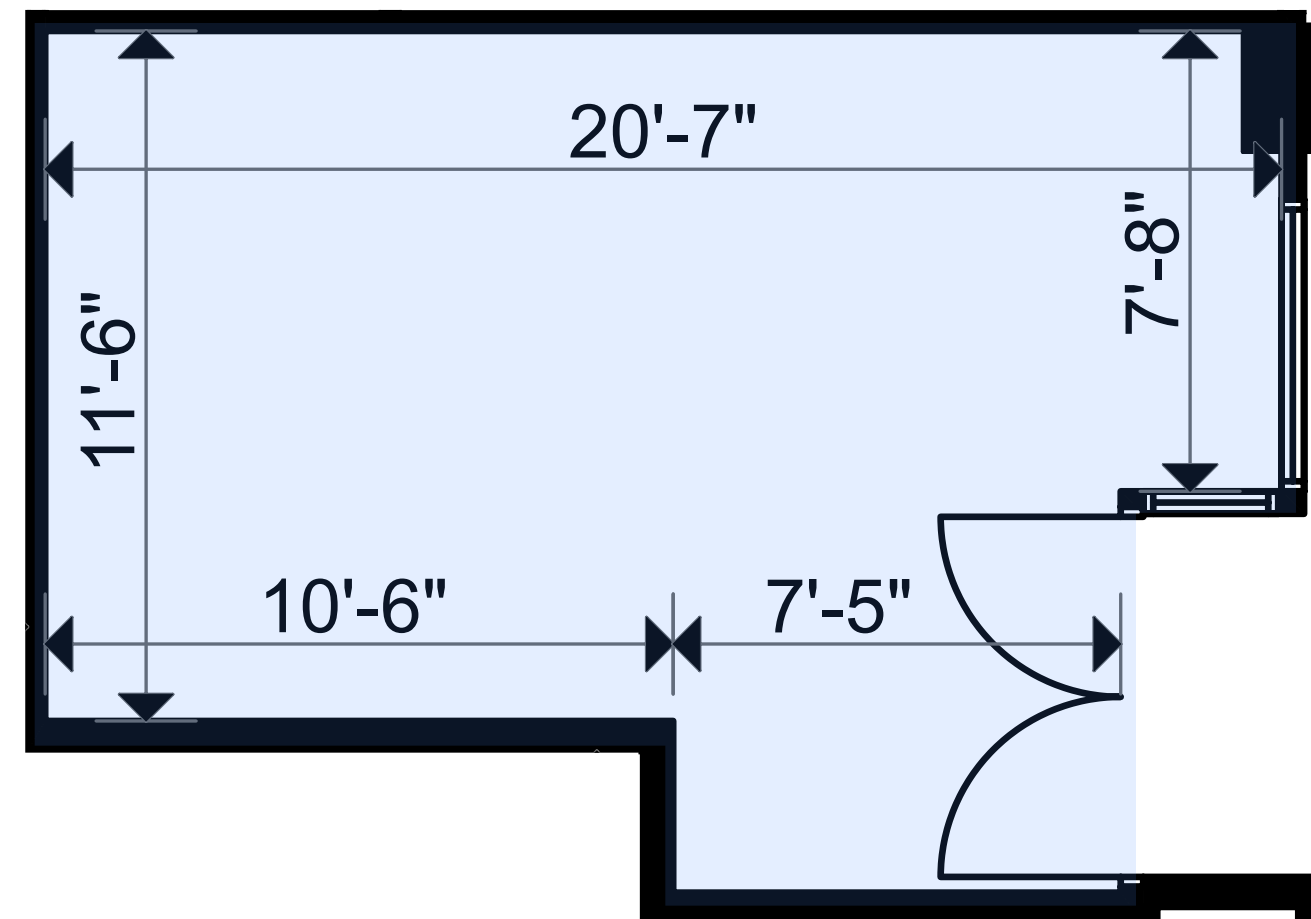

Plaza Two

SUITE 103

2,354 SF

- Ground floor space with one office and a small kitchenette.

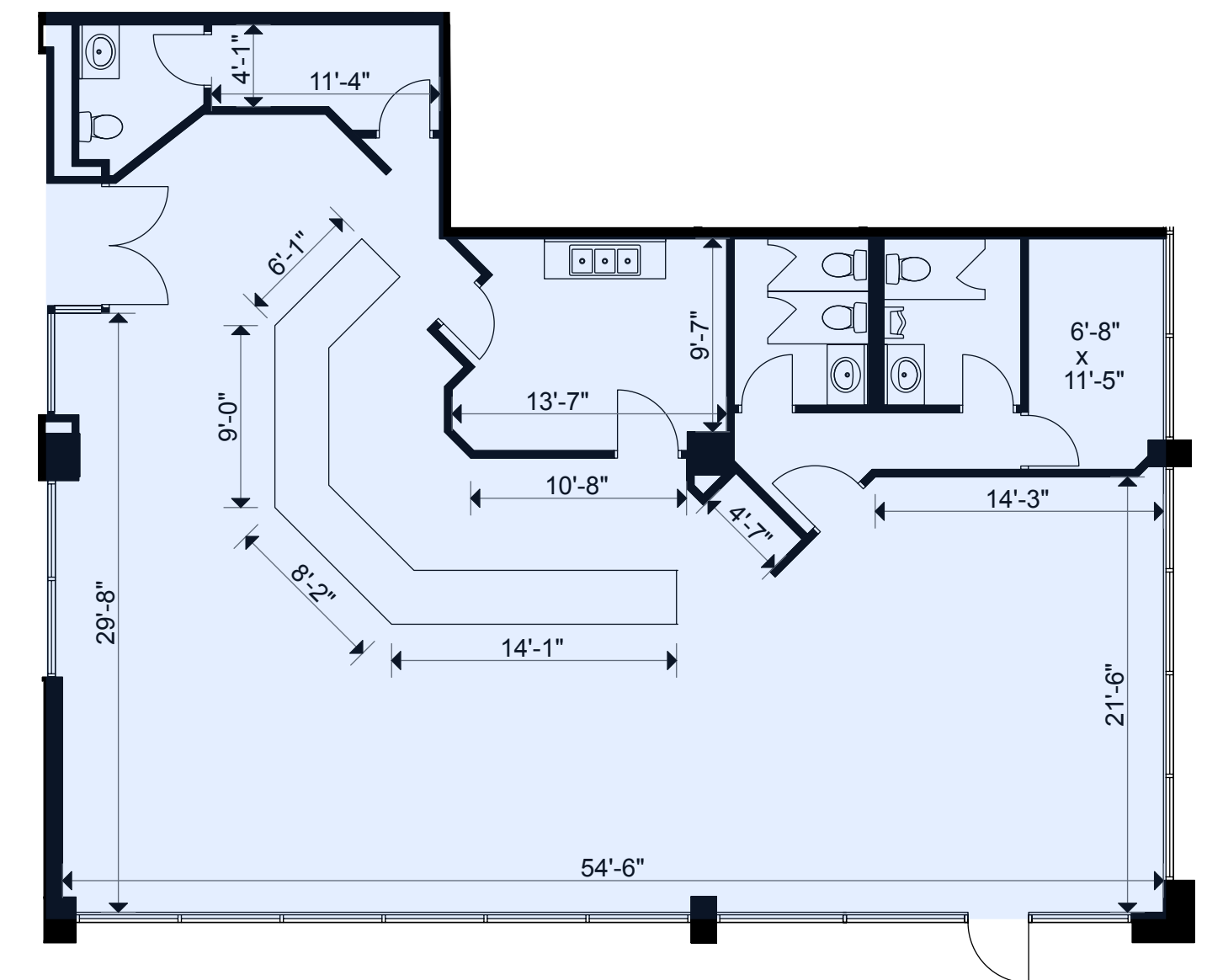

[BACK TO AVAILABILITES](#)



Plaza Two

SUITE 107

1,919 SF

- April 1, 2025
- Built-out suite
- Open work space

VIRTUAL TOUR

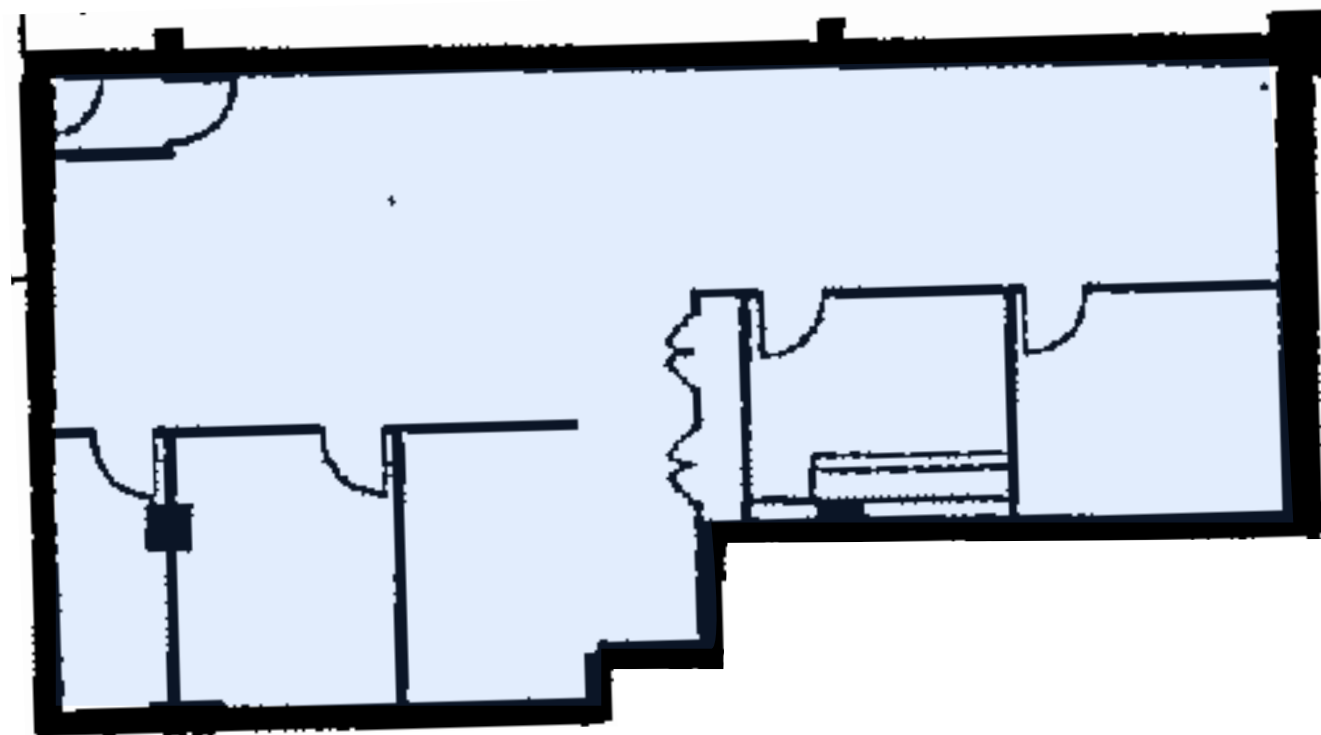

Plaza Two

SUITE 300

9,847 SF

- Office space built out with mixture of private offices, boardroom and kitchen.

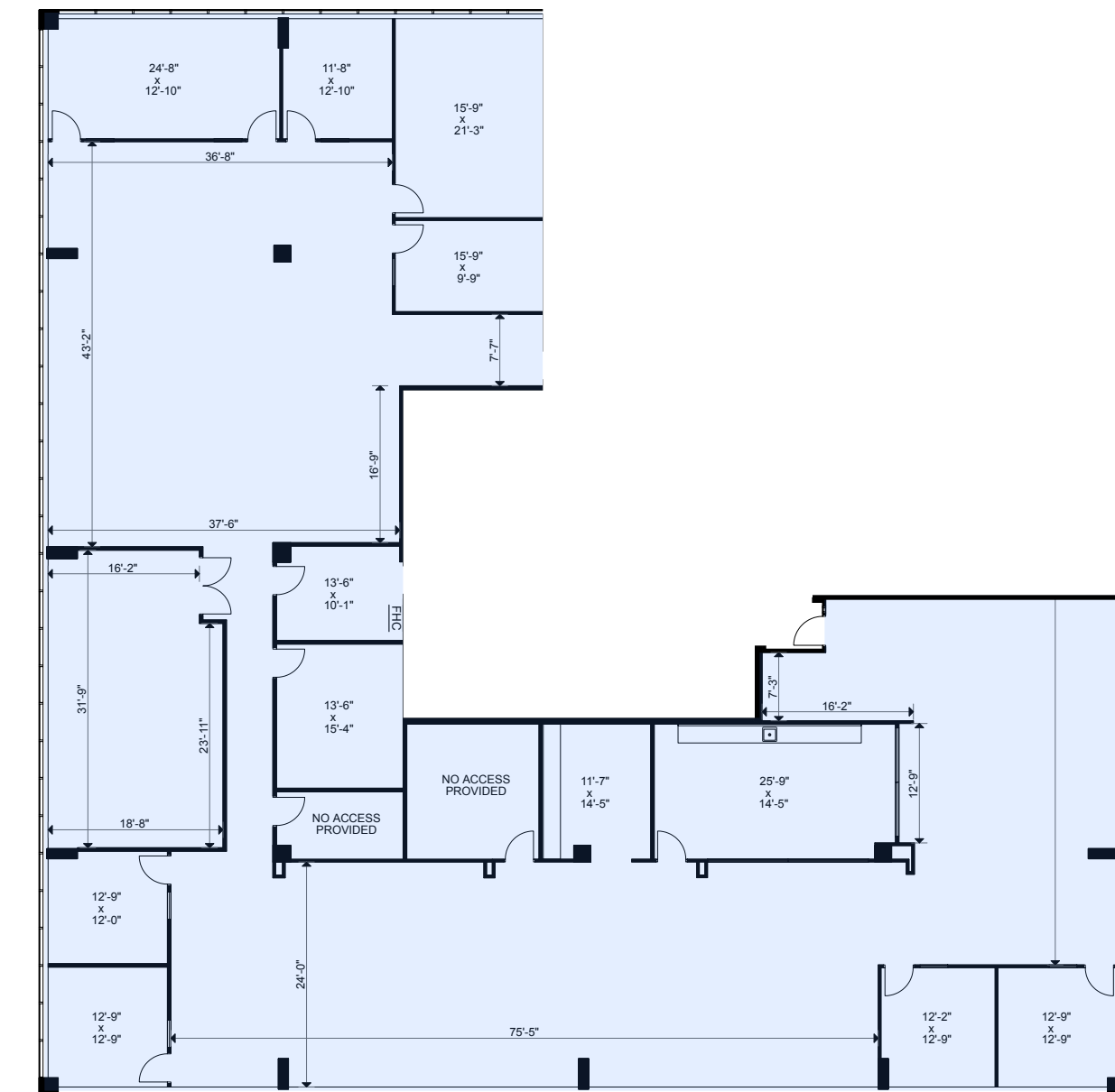

[BACK TO AVAILABILITES](#)



Plaza Two

SUITE 320

3,358 SF

- Built-out suite
- Open work space



Plaza Three

SUITE 300

4,605 SF

- Built-out suite
- Open work space
- Contiguous with suite 303 for a total of 7,750 SF

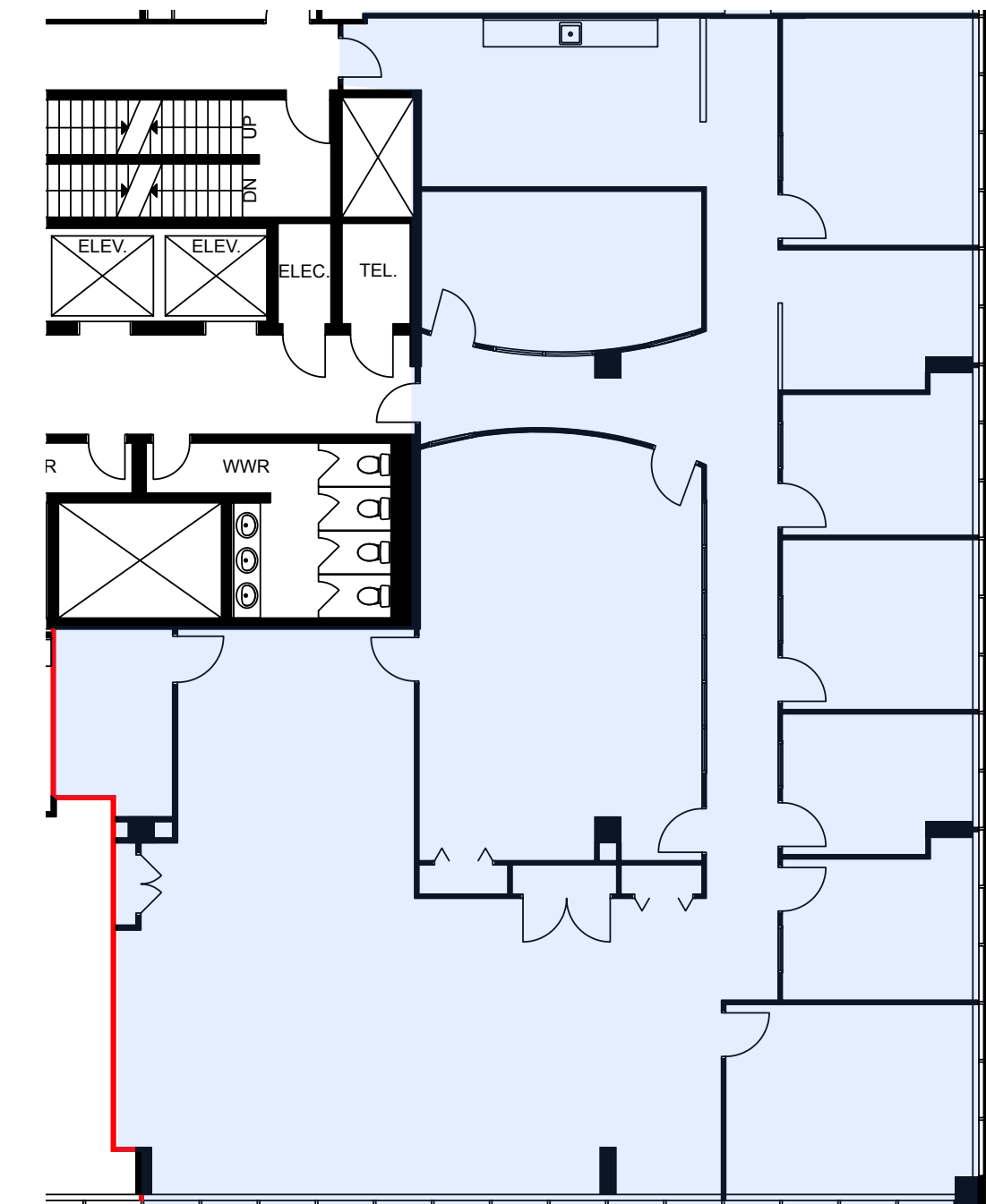

[BACK TO AVAILABILITES](#)



Plaza Three

SUITE 301

4,165 SF

- Model Suite
- Office space built out with mixture of private offices, boardroom and kitchen.

VIRTUAL TOUR

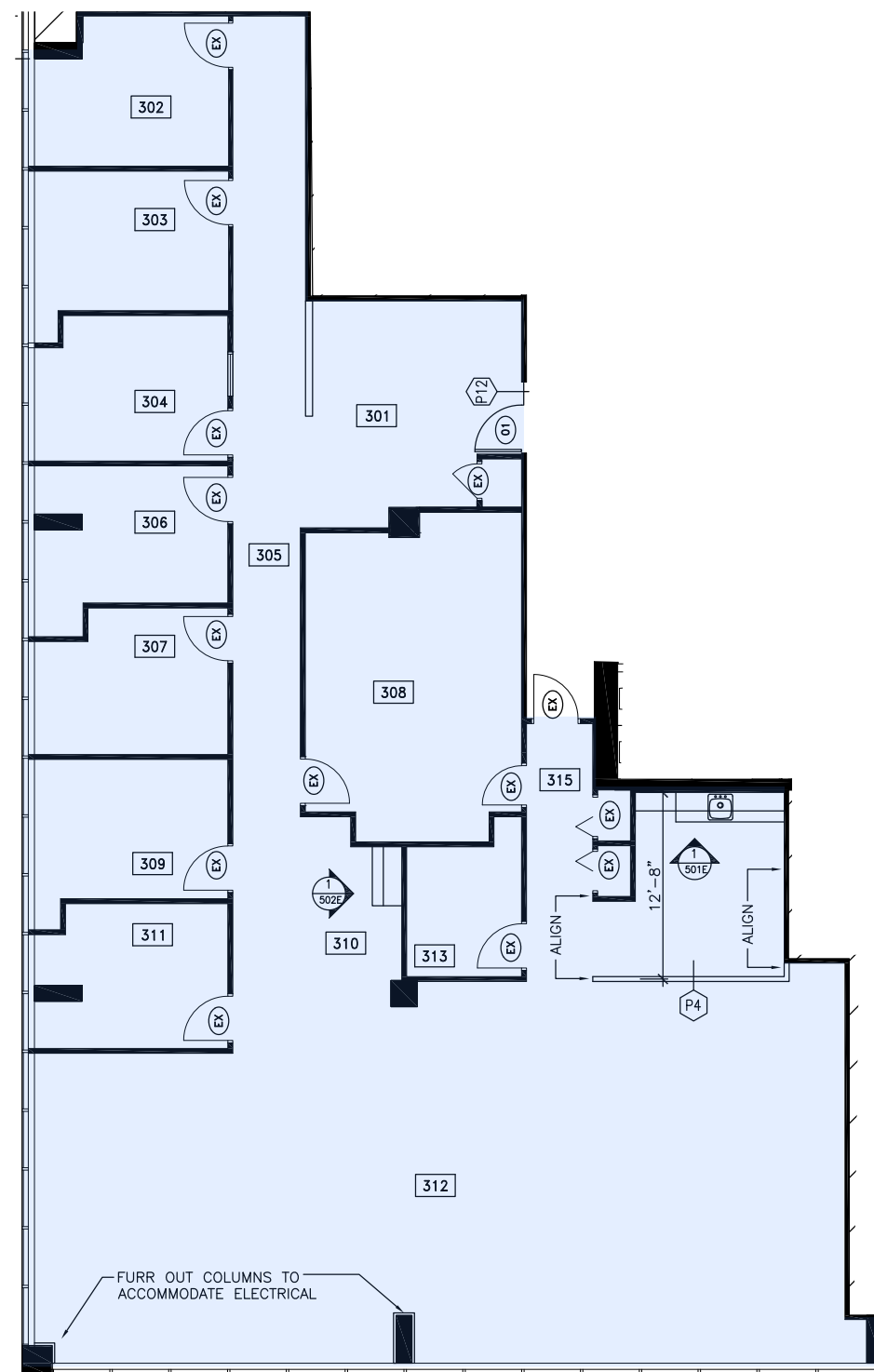

Plaza Three

SUITE 303

3,145 SF

- Office space built out with mixture of private offices, boardroom and kitchen.
- Contiguous with suite 300 for a total of 7,750 SF

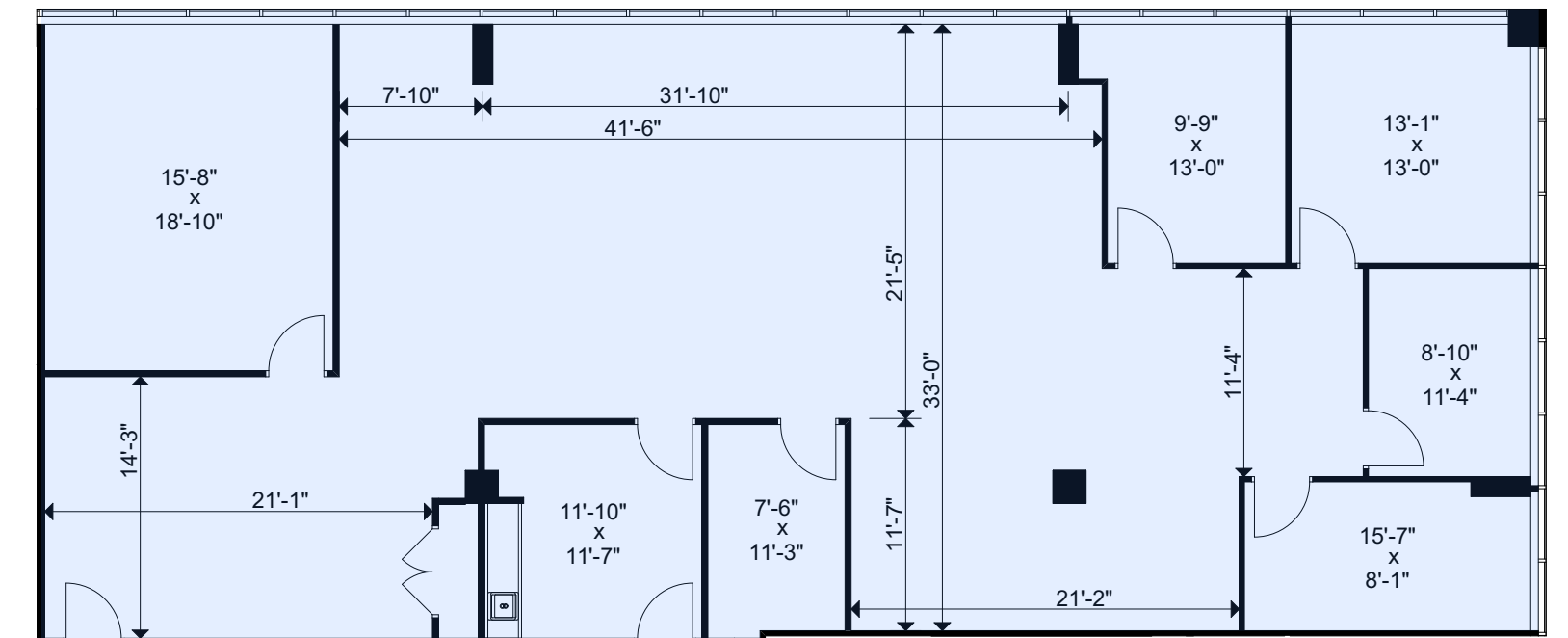

BACK TO AVAILABILITES



Plaza Four

SUITE 110

3,491 SF

- Open work space, no build out

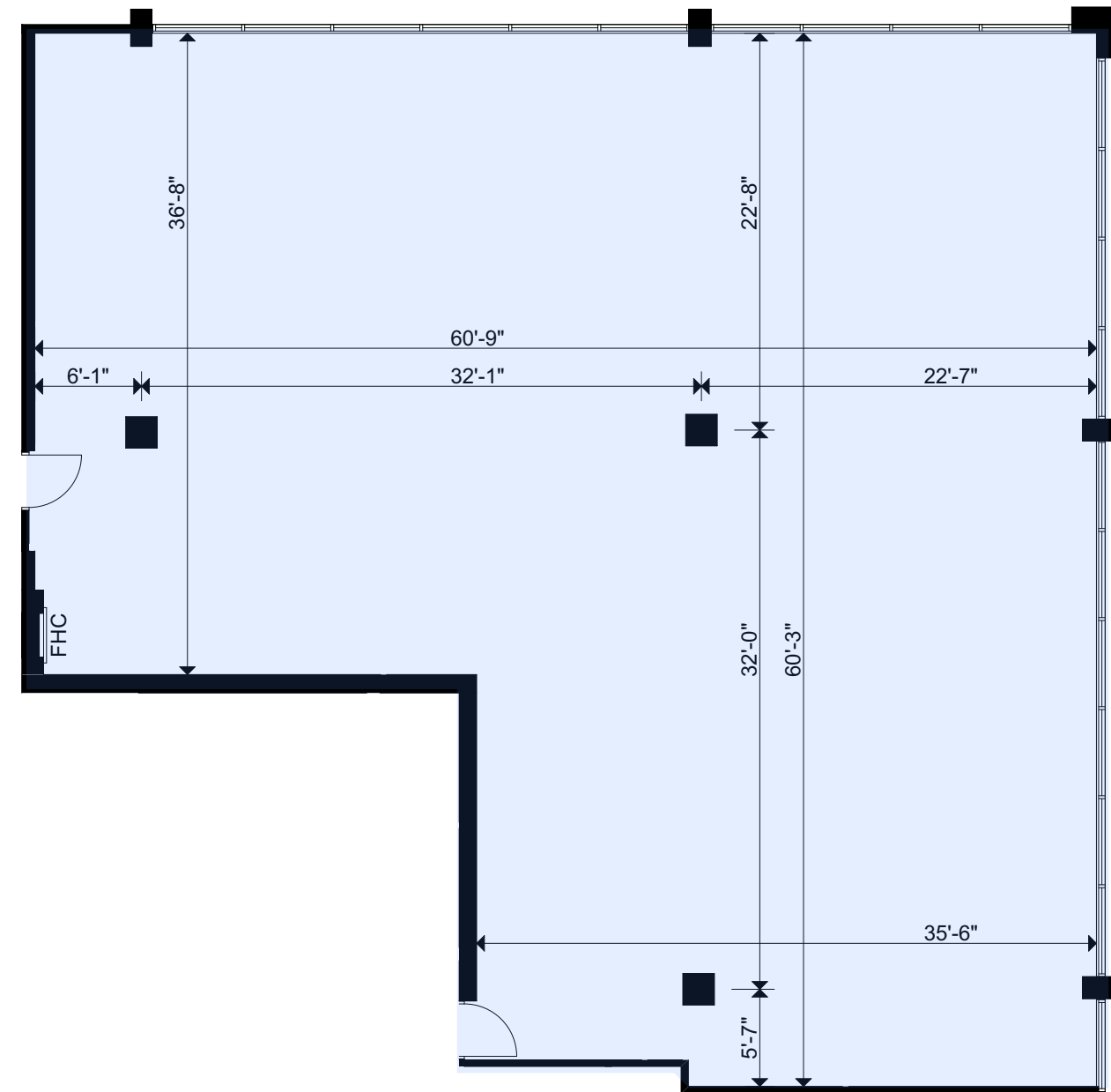

Plaza Five

SUITE 200

13,388 SF

- Partially built-out

VIRTUAL TOUR

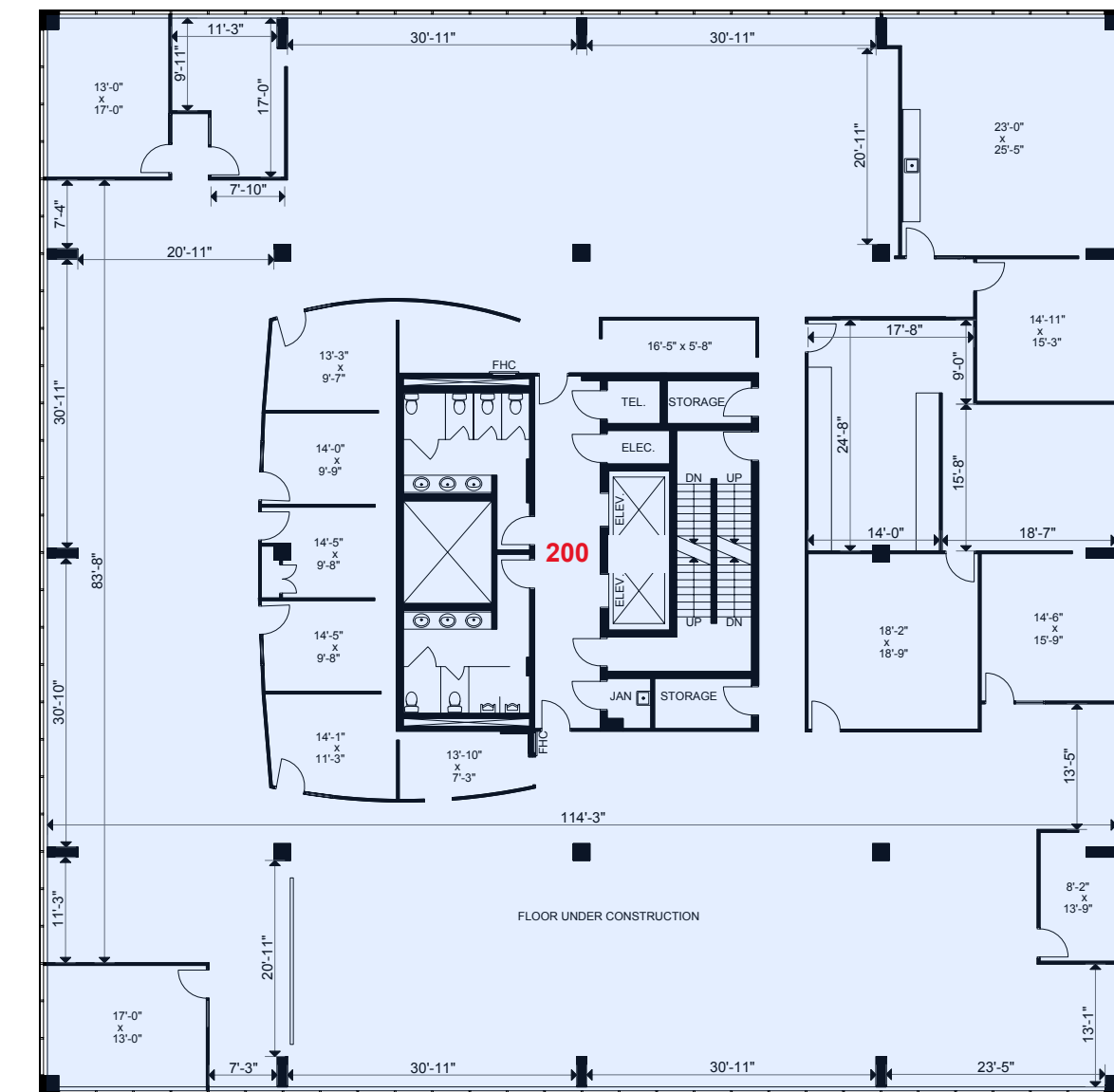

BACK TO AVAILABILITES



Plaza Five

SUITE 406

2,594 SF

- Built-out space
- Six private offices

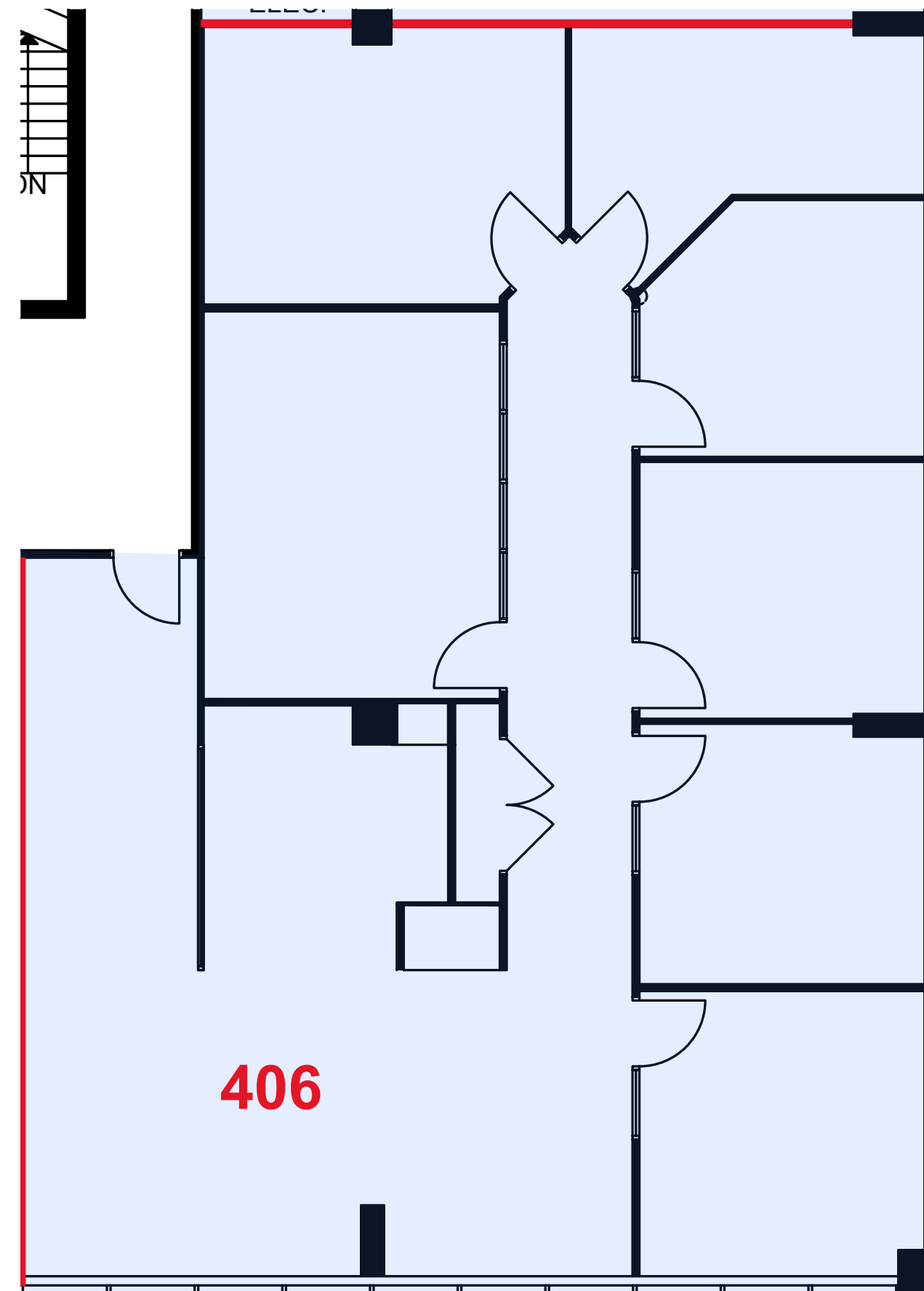

[BACK TO AVAILABILITES](#)





PROPERTY LOCATION

2000 Argentia Road is located one block south from Highway 401 and Mississauga Road with several amenities within the area including 21,000 square foot Wynn Fitness Club. Located directly across from 2000 Argentia Road is Mullet Creek Park with walking paths to keep you active and get your steps in

DRIVE TIMES			
3 Mins to 401	10 Mins to 403	5 Mins to 407	5 Mins to GO
17 Mins to 427	15 Mins to Square One	20 Mins to Pearson Airport	

1 Chop Steakhouse	9 Tim Hortons
2 St. Louis Bar & Grill	10 Mullet Creek Park
3 Movati Athletic	11 Meadowvale Sports Park
4 RBC Royal Bank	12 McDonald's
5 Subway	13 Mississauga Four Rinks
6 Crunch Fitness	14 Lake Aquitane Park
7 Wind Japanese and Thai	15 Lazros Greek Grills
8 Meadowvale GO Station	16 Meadowvale Town Centre

2000

ARGENTIA ROAD GALLERY





Accelerating success.

2000 Argentia Road, Mississauga | ON

Chris Burans*

Senior Vice President

+1 416 620 2866

chris.burans@colliers.com

Noel Cardy

Sales Representative

+1 416 620 2364

noel.cardy@colliers.com

Adam Dauphinee**

Senior Vice President, LEED, AP

+1 416 620 2872

adam.dauphinee@colliers.com

Anmol Dhalla*

Sales Representative

+1 647 255 2559

anmol.dhalla@colliers.com

This document has been prepared by Colliers for advertising and general information only. Colliers makes no guarantees, representations or warranties of any kind, expressed or implied, regarding the information including, but not limited to, warranties of content, accuracy and reliability. Any interested party should undertake their own inquiries as to the accuracy of the information. Colliers excludes unequivocally all inferred or implied terms, conditions and warranties arising out of this document and excludes all liability for loss and damages arising there from. This publication is the copyrighted property of Colliers and/or its licensor(s). Copyright © 2025. All rights reserved. This communication is not intended to cause or induce breach of an existing listing agreement. Colliers Macaulay Nicolls Inc., *Sales Representative **Broker