

RATIO



Innovation Campus
Emeryville

6401 Hollis &
1480 64th

Beacon
Capital Partners

Newmark

READY TO RUN LABS





AVAILABLE NOW FOR TENANT IMPROVEMENTS	1480 64th Street - R:2 98,351 SF 3-story building	+ SECOND FLOOR: 33,461 SF
AVAILABLE FOR TENANT IMPROVEMENTS JANUARY 2025	6401 Hollis Street - R:1 142,565 SF Single story building with mezzanine	+ SUITE 175: 32,109 SF
POWERFUL UTILITY	Exceptional labs with robust infrastructure to support cutting	+ FULLY DESIGNED CHEMISTRY & BIOLOGY LABS + 3,000A 480/277V 3-PHASE 4-WIRE SERVICE TO EACH BUILDING + NEW ROOFTOP AHU PROVIDING 2.0 FCM PER SF WITH 100% ONCE-THROUGH OUTSIDE AIR + EMERGENCY STANDBY POWER OF 5W/RSF OF LAB PREMISES
SCALABLE SPACE	A flexible facility that scales with your growth.	+ SUITES FROM 16,000 TO 35,000 SF + NEW 4,500 LB SERVICE ELEVATOR
IDEAL ENVIRONMENT	A private campus environment designed with the perfect mix of people, purpose, and place.	+ COURTYARD WITH SOCIAL HUB & WORK SPACES + TRANSFORMED LOBBIES + UNIQUE OPEN WOOD TRUSS STRUCTURE (R:1) + NEWLY RENOVATED FITNESS CENTER + SPA-INSPIRED LOCKERS AND SHOWERS + ART INSTALLATIONS + DAYLIGHT IN >75% OF REGULARLY OCCUPIED SPACES + 3:1000 RSF PARKING RATIO
STRATEGIC SETTING	Centrally located on Hollis Street, the heart of Emeryville's fast-growing life sciences cluster.	+ CLOSE TO INNOVATION DRIVERS, FROM UC BERKELEY AND LBNL, TO STARTUPS, INCUBATORS, AND LIFE SCIENCES WORLD LEADERS + CLOSE-BY RETAIL & RESIDENTIAL OPTIONS
RESPONSIVE OWNERSHIP	Owned by Beacon Capital Partners, a tenant-focused real estate investment firm.	+ ENABLING SCIENCE THROUGH RELIABLE OPERATIONS AND OPTIMIZED FM SERVICES DELIVERY + 29M SF NATIONAL PORTFOLIO, 12.6M SF OF TOTAL LIFE SCIENCE SPACE + \$14B+ AUM + 75-YEAR LEGACY

ROOM FOR YOUR MIND TO WANDER



With a \$24M upgrade, RATIO's new courtyard, inspired lobbies, high-end amenities, creative office spaces and chemistry and biology labs make it the ideal platform for the world's most transformative ideas.

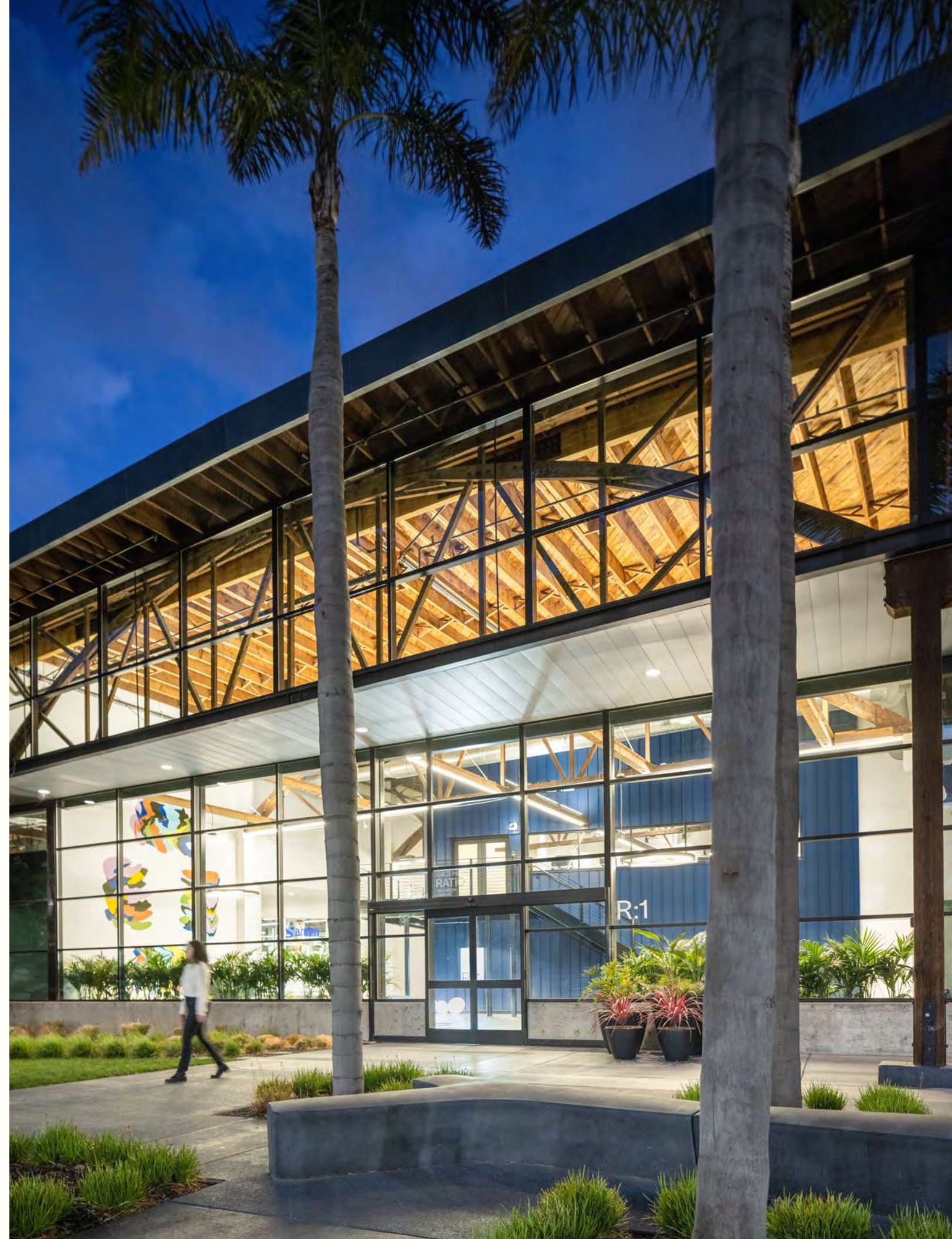
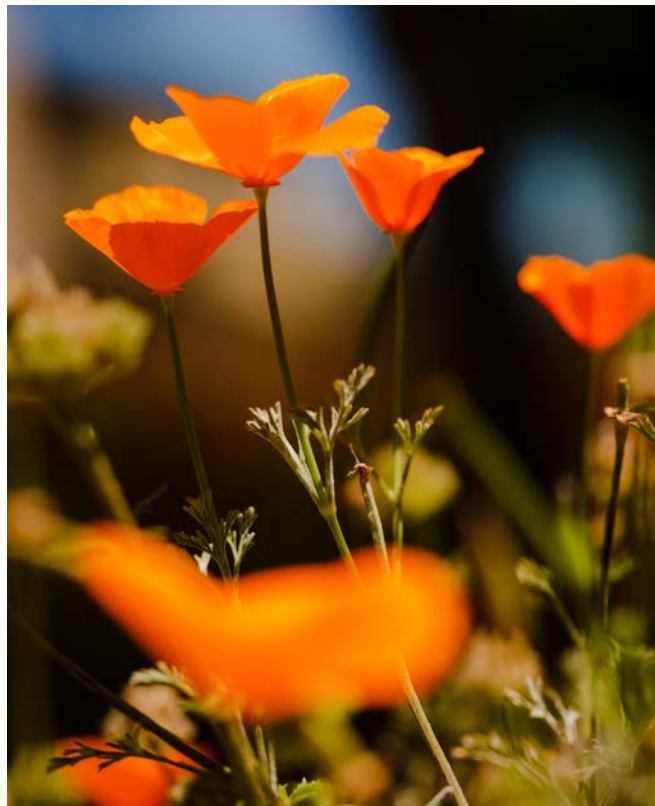

Sport Court

R:1

6401 Hollis Street
142,565 SF, Single Story

+ 32,109 SF Available
January 2025

Parking Garage

637 Spaces
Five Stories
8 EV Chargers
Secure Bike Storage

Fitness Center

Outdoor
Work
Space

Outdoor Social Hub

Loading Bay

R:2

1480 64th Street
98,351 SF, three Stories

+ 33,461 SF Available Now
for TI's

Loading Bay

PROPERTY ENTRANCE

64TH STREET

OVERLAND AVENUE

HOLLIS STREET

AMENITIES

Private gardens, purpose-built labs, and curious thinkers. RATIO offers room to explore in an environment that makes work feel like play.

- + TRANSFORMED LOBBY SPACES
- + NEW EXTERIOR AMBIENT LIGHTING AND FURNITURE THROUGHOUT CAMPUS
- + PRIVATE AND CONVENIENT FITNESS CENTER
- + SPA-INSPIRED LOCKERS AND SHOWERS
- + OUTDOOR SOCIAL HUB SURROUNDED BY GREENERY
- + HAND-CURATED COLLECTION OF ART INSTALLATIONS



AMENITIES FOR BETTER BALANCE



TRANSFORMED R:1 LOBBY

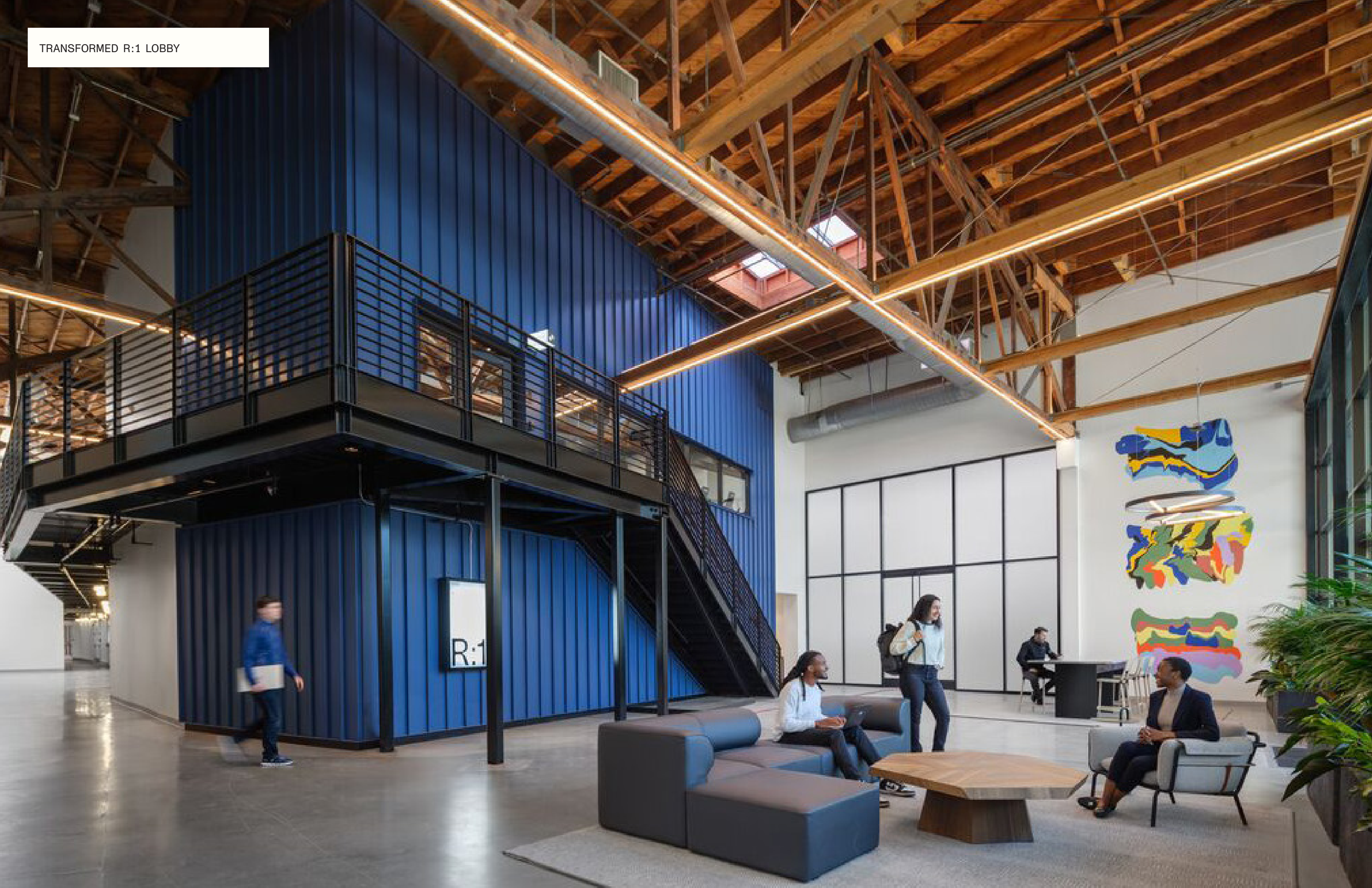

R:2 - LABS WITH LIGHT





Base Building upgrades are underway to accommodate life science users on the 2nd floor of R:2.

EXCEPTIONAL LAB SPACES
THAT ARE READY TO RUN

- + 3,000A 480Y/277V 3-PHASE 4 WIRE SERVICE TO EACH BUILDING
- + EMERGENCY STANDBY POWER AVAILABLE OF 5W/RSF OF LAB PREMISES
- + NEW ROOFTOP AHU PROVIDING 2.0 CFM PER SF, WITH 100% ONCE THROUGH OUTSIDE AIR
- + NEW BOILER SKIDS AND PUMPS
- + NEW LAB EXHAUST FAN CLUSTER WITH CAPACITY FOR NEW FUME HOODS
- + NEW ROOFTOP LAB EXHAUST
- + 17'-23' CEILINGS IN R:1, SUITE 100
- + 16' SLAB TO SLAB HEIGHTS ON THE 1ST AND 2ND FLOOR OF R:2
- + 15'6 SLAB TO SLAB HEIGHT ON THE 3RD FLOOR OF R:2

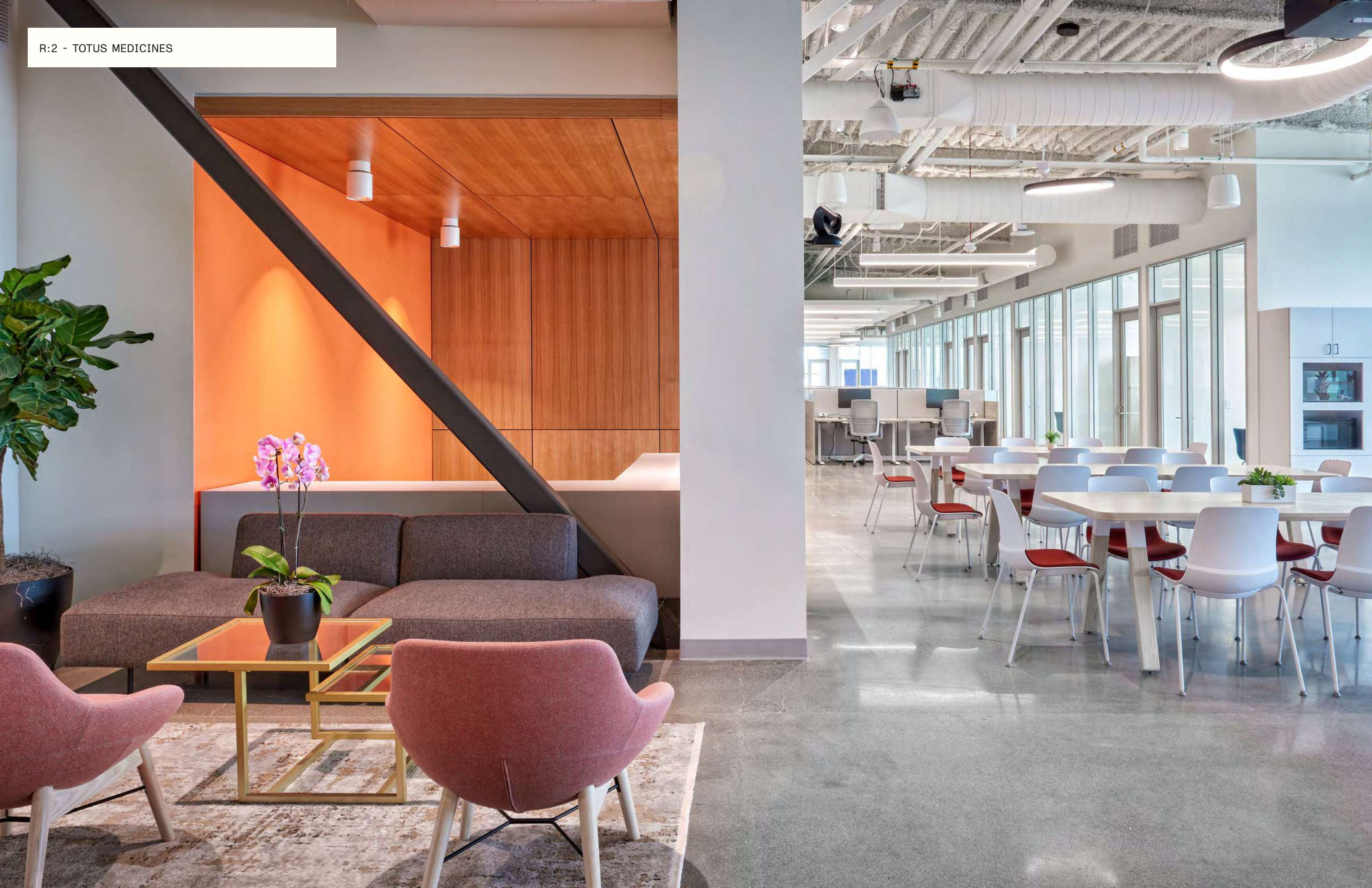

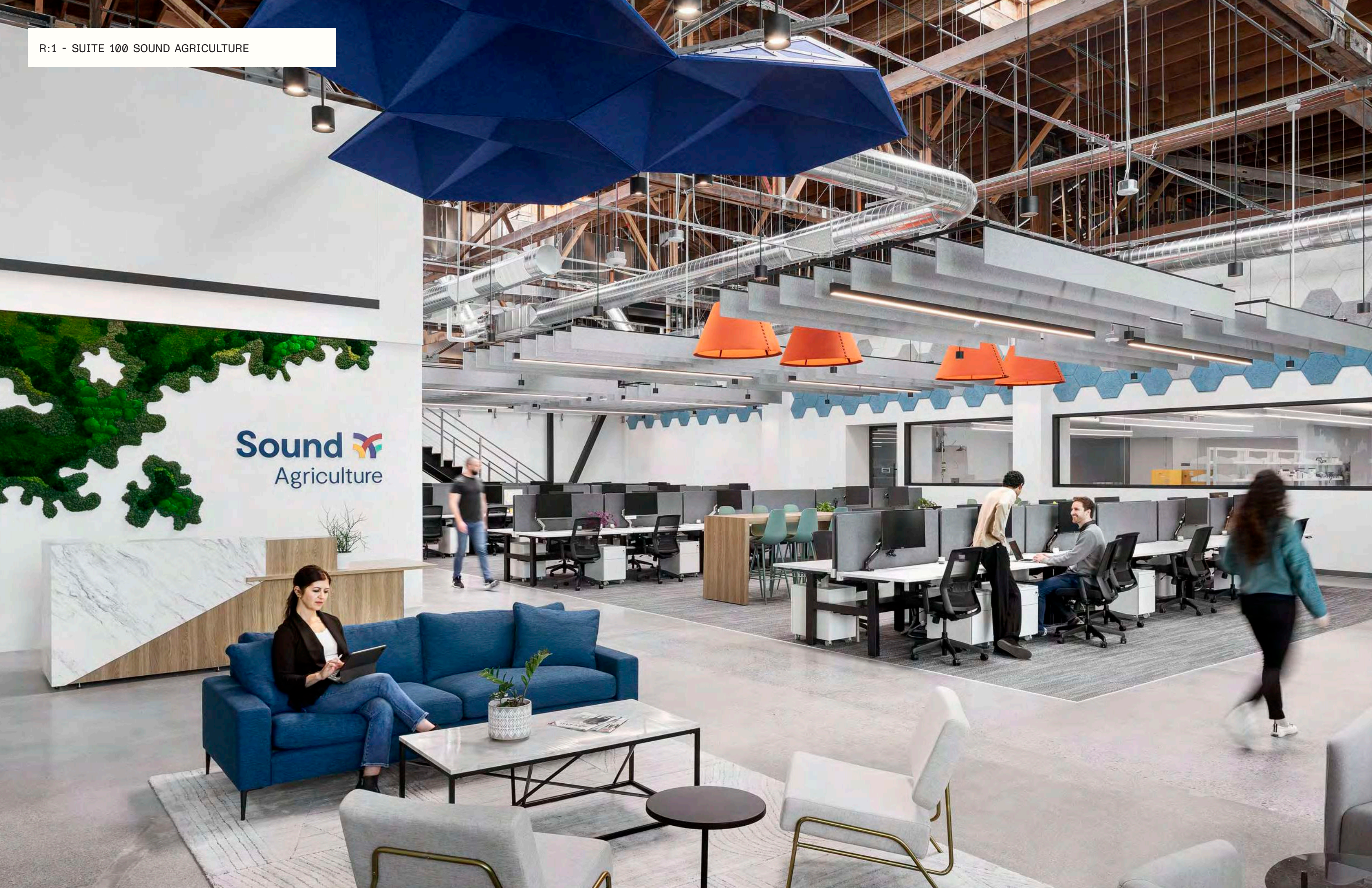

Sound 
Agriculture

RENDERINGS - R:2 SECOND FLOOR

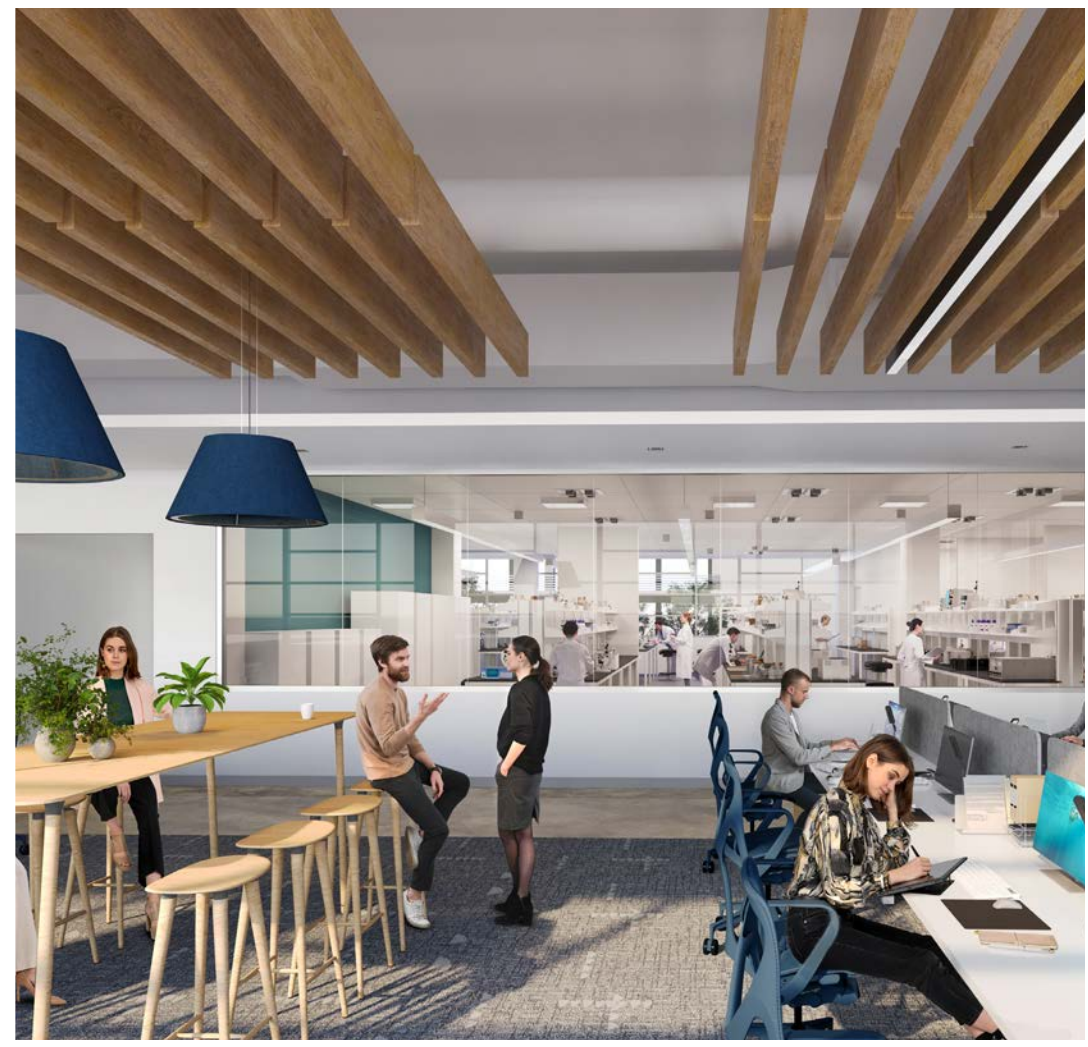
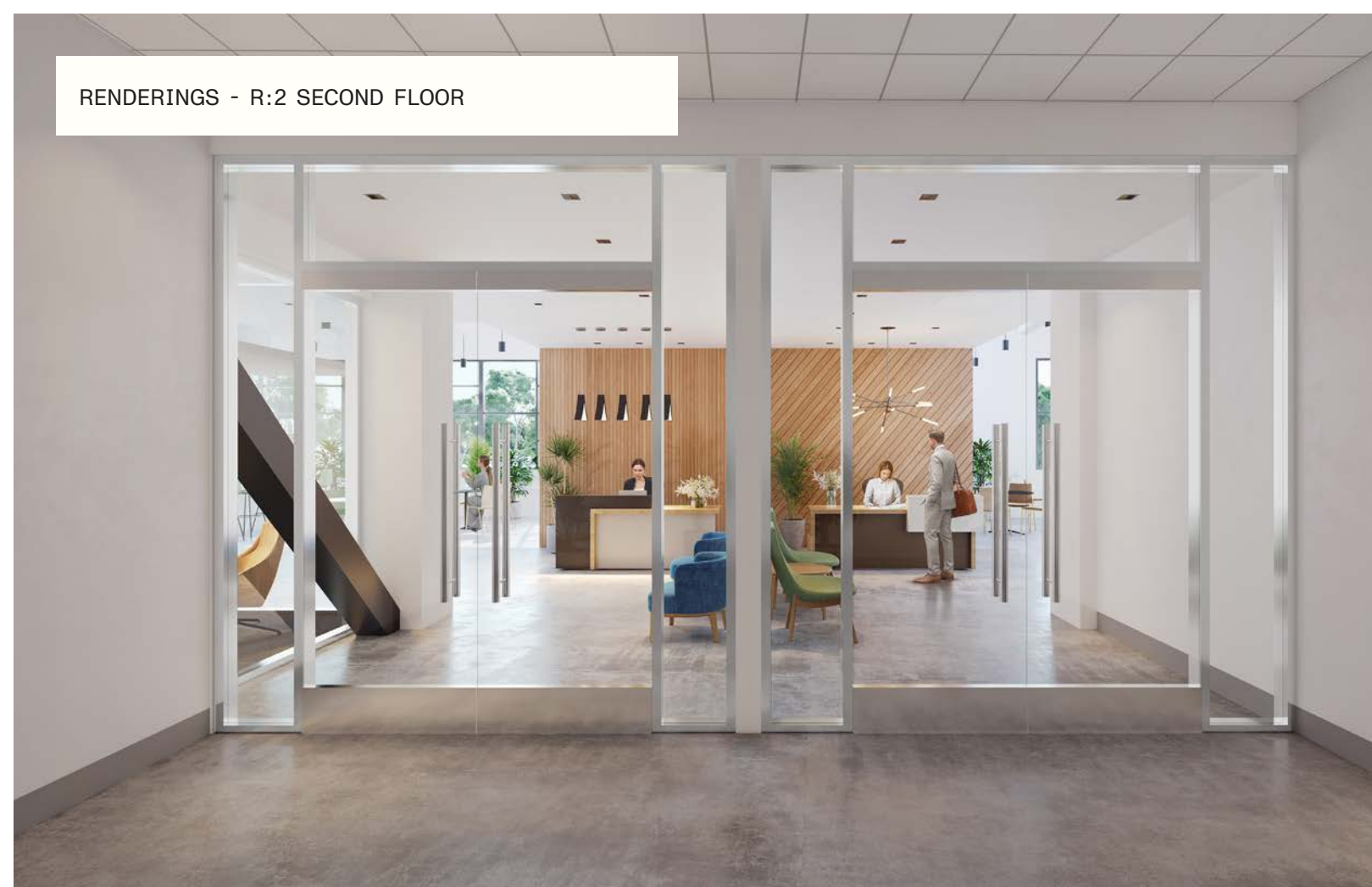

Suite 250
R:2 - Partial 2nd Floor
15,800 SF

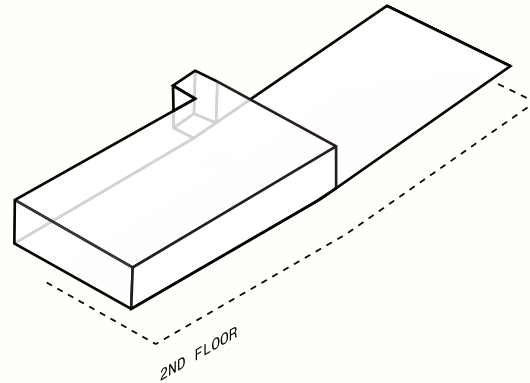

- + LAB / OFFICE RATIO (55:45)
- + LAB BENCHES (87)
- + TECH DESK (48)
- + MEETING & OFFICE (11)
- + 600 KW GENERATOR SERVICES
- + NEW ROOFTOP AHU PROVIDING 2.0 CFM PER SF
- + 2 FUME HOODS
- + NEW ROOFTOP LAB EXHAUST
- + 15'6 SLAB TO SLAB HEIGHT

- LAB
- LAB SUPPORT
- OFFICE
- COLLABORATION

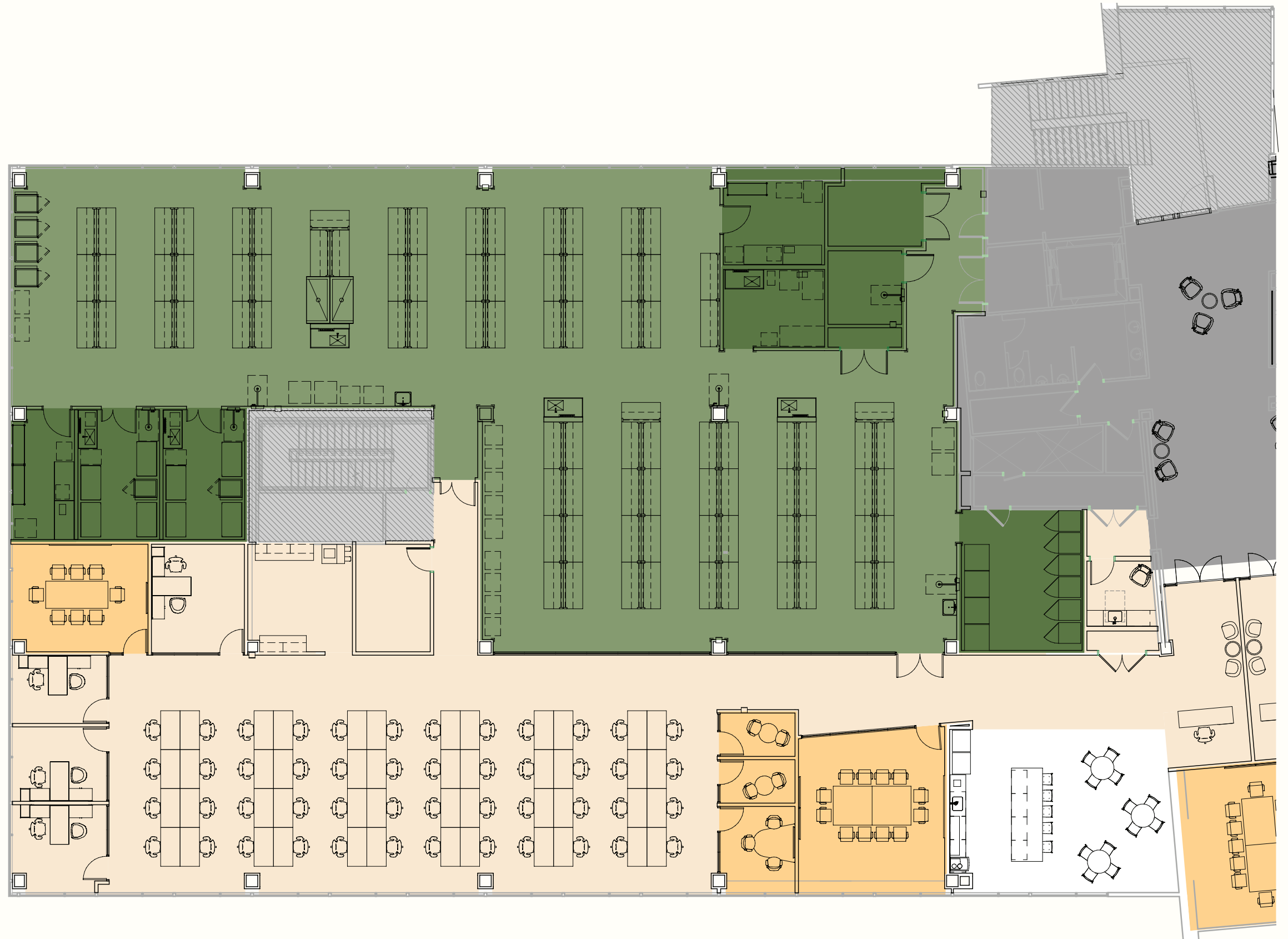

Suite 200
R:2 - Partial 2nd Floor
17,700 SF

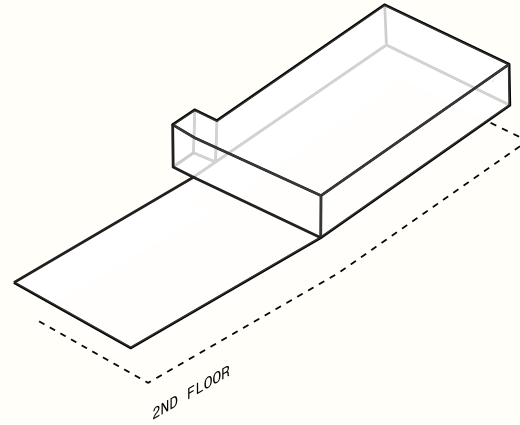

- + LAB / OFFICE RATIO (55:45)
- + LAB BENCHES (91)
- + TECH DESK (48)
- + MEETING & OFFICE (10)
- + 600 KW GENERATOR SERVICES
- + NEW ROOFTOP AHU PROVIDING 2.0 CFM PER SF
- + 2 FUME HOODS
- + NEW ROOFTOP LAB EXHAUST
- + 15'6 SLAB TO SLAB HEIGHT

- LAB
- LAB SUPPORT
- OFFICE
- COLLABORATION

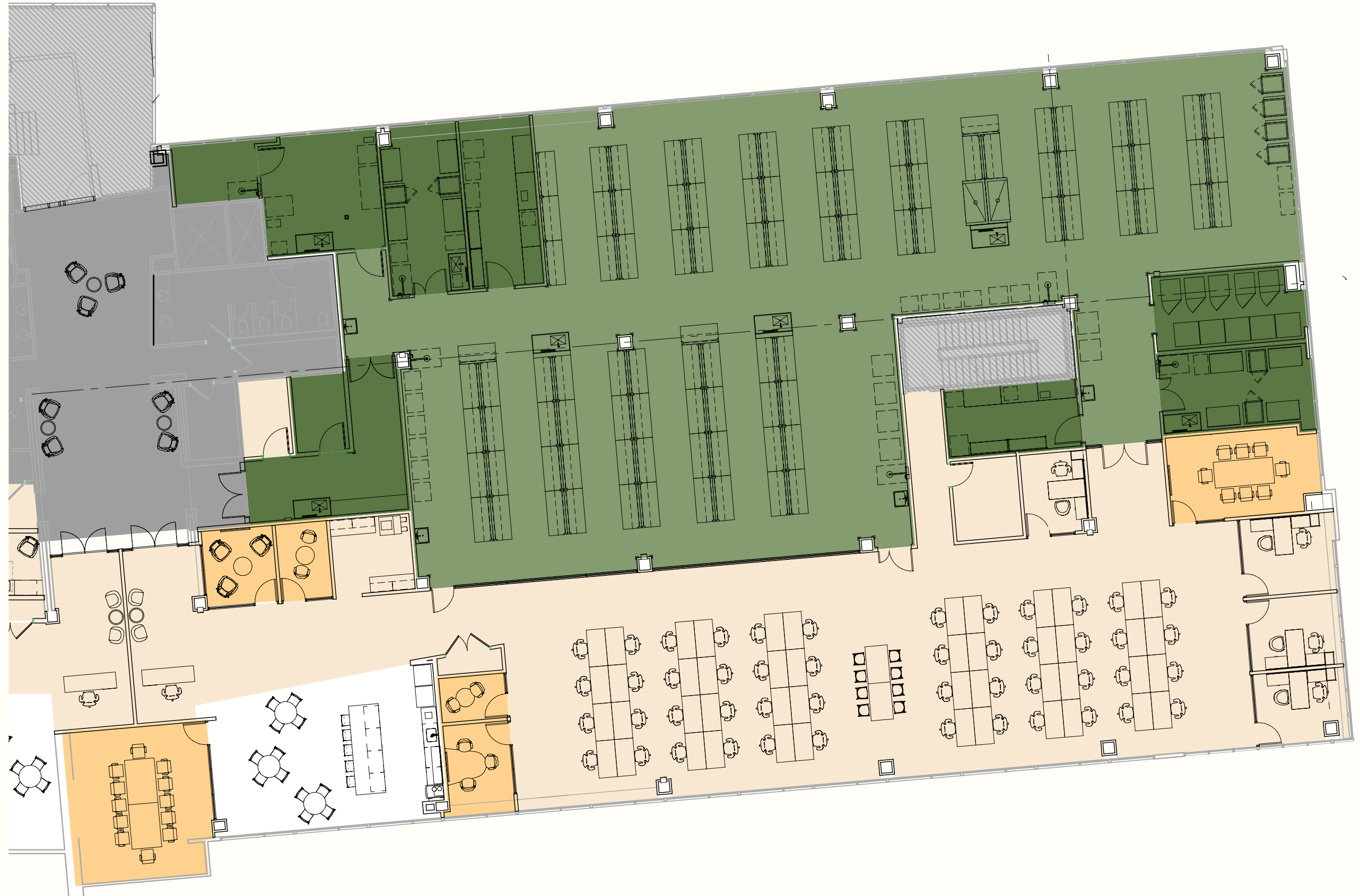

Suite 175
R:1 - Partial 1st Floor
32,109 SF

- + RECEPTION
- + WAITING AREA
- + CONFERENCE ROOM
- + BREAKOUT/HUDDLE ROOM
- + PHONE BOOTH
- + KITCHEN
- + CAFE
- + RESTROOMS
- + STORAGE/SERVICE
- + LIBRARY

- OFFICE
- COLLABORATION
- - MEZZANINE

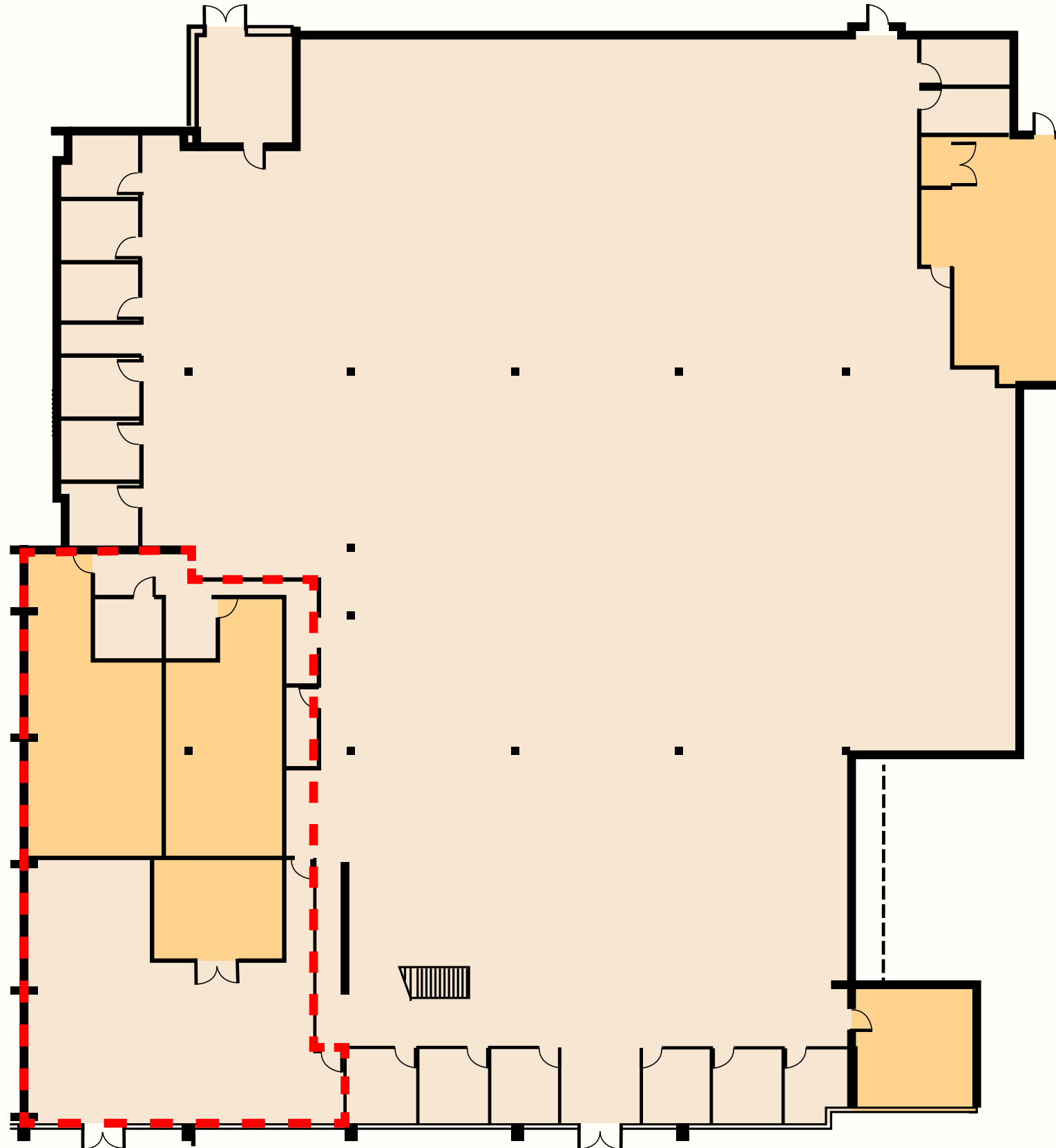



- + BAY AREA'S FASTEST-GROWING LIFE SCIENCE CLUSTER
- + WALKING DISTANCE TO EMERYVILLE PUBLIC MARKET, HOME TO 18+ DINING OPTIONS AND UNIQUE RETAIL
- + 15 MINUTES FROM LAWRENCE BERKELEY NATIONAL LAB



IDEALLY LOCATED
IN THE HEART
OF EMERYVILLE

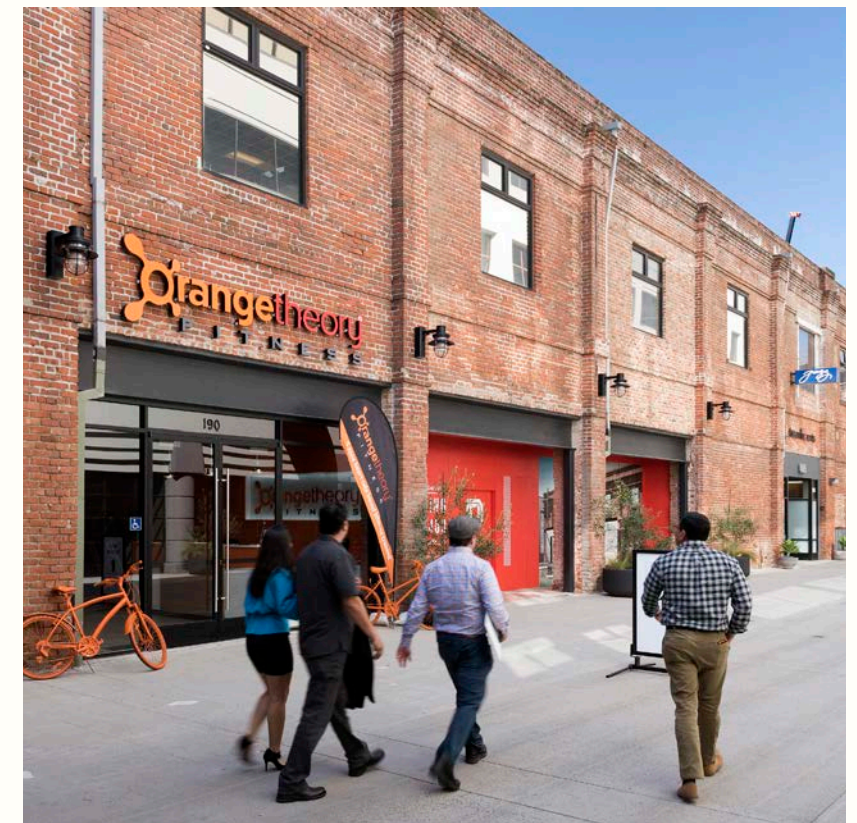

RATIO Innovation Campus is centrally located on Hollis Street, the heart of Emeryville's fast-growing life sciences cluster.

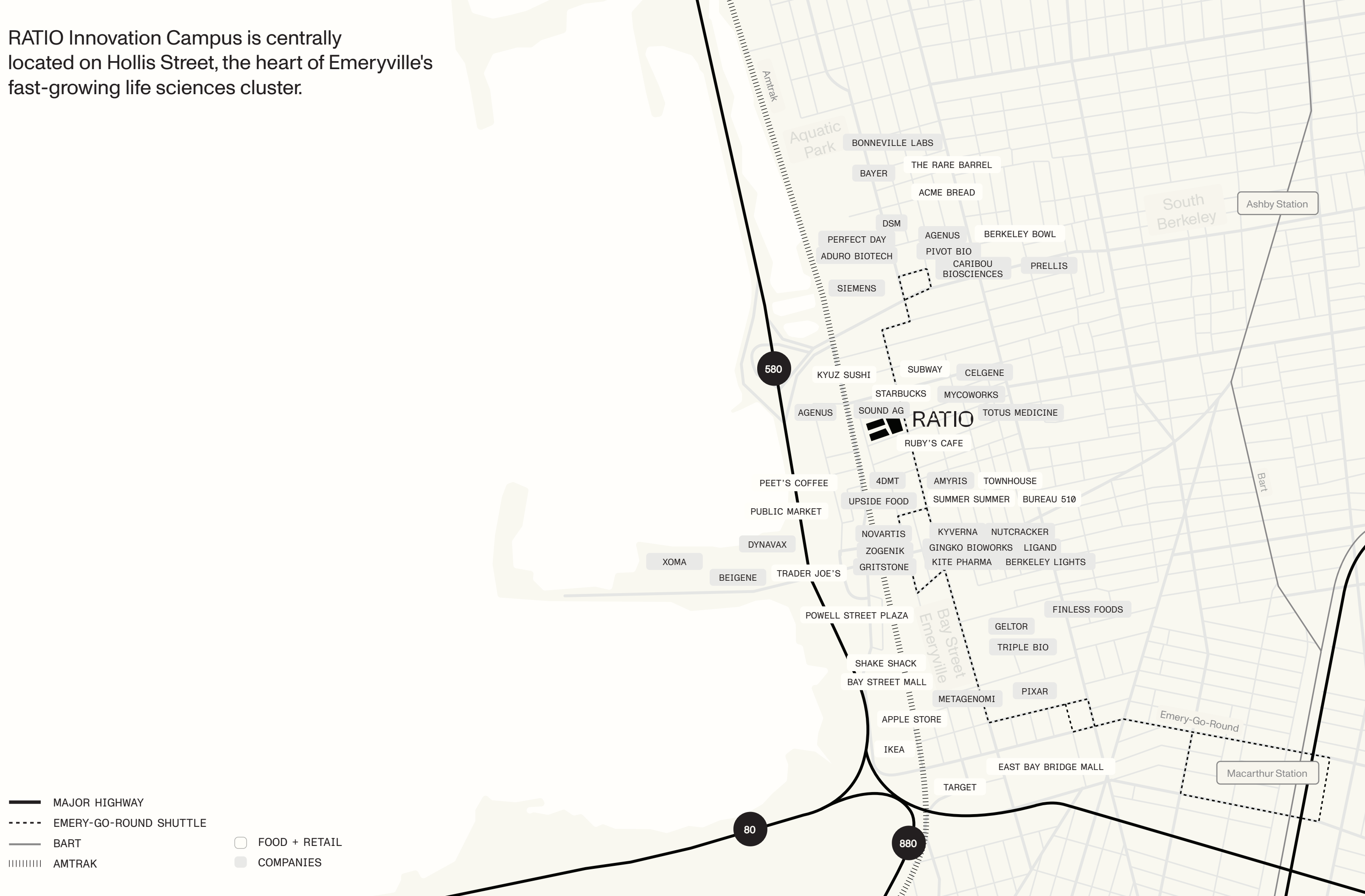

- MAJOR HIGHWAY
- EMERY-GO-ROUND SHUTTLE
- BART
- AMTRAK
- FOOD + RETAIL
- COMPANIES

Beacon Capital

75 years

of successful real estate development, ownership, and management



100+

real estate professionals



\$19B+

raised in equity since 1998 from a diverse investor group



55M

square feet of LEED certifications since 2009

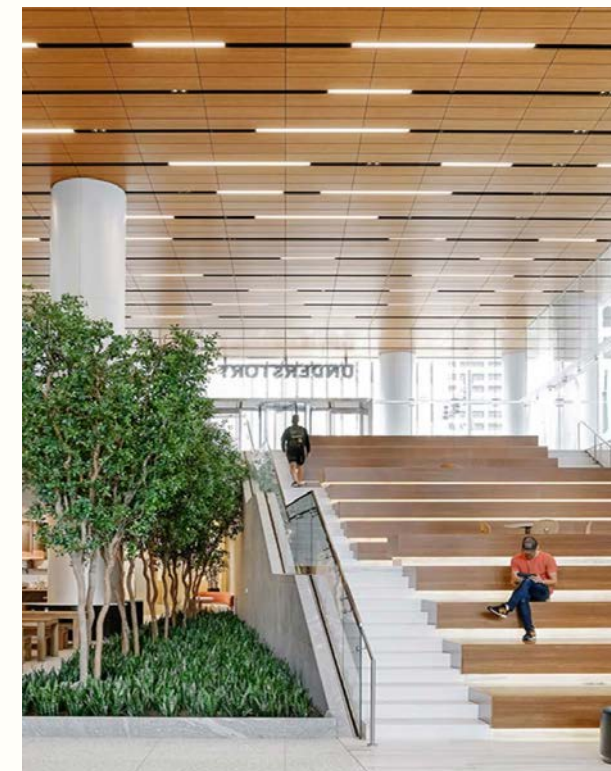

Beacon Capital

12.6 MILLION SF

TOTAL LIFE SCIENCE PORTFOLIO

4.7 MILLION SF

EXISTING AND UNDER CONSTRUCTION

7.9 MILLION SF

FUTURE DEVELOPMENT

BEACON LABS ARE HOME TO LEADING SCIENTISTS
AND INNOVATORS AT:



SOUTHLINE BOSTON
BOSTON, MA
760,000 SF



2 HARBOR
BOSTON, MA
418,000 SF



BERKELEY COMMONS
BERKELEY, CA
516,000 SF



HYDE PARK LABS
CHICAGO, IL
288,000 SF

RATIO

ADDRESS

6401 Hollis Street
Emeryville, CA 94608

OWNER

Beacon Capital Partners
beaconcapital.com

LEASING
TEAM

Newmark
nmrk.com

Bill Benton
Vice Chairman
bbenton@nmrk.com
415.806.2455
CA RE Lic. 01247617

Conor Ranahan
Managing Director
cranahan@nmrk.com
510.923.6204
CA RE Lic. 01850797

PROPERTY
MANAGEMENT

CBRE
cbre.com

Alisa Orris
Sr. Property Manager
alisa.orris@cbre.com
510.874.1945