

LIFE SAFETY SYMBOLS & NOTES – GENERAL NOTES	
	EXIT SIGN / EMERGENCY LIGHT COMBO UNIT (HARD WIRED & BATTERY BACK UP)
	EMERGENCY LIGHT AT +/-7'-0" AFF (HARD WIRED AND BATTERY BACK UP)
	DIRECTIONAL EXIT SIGN – ARROW INDICATED (HARD WIRED & BATTERY BACK UP)
	WALL MOUNTED FIRE EXTINGUISHER SEE PLAN FOR TYPE
EMERGENCY LIGHTING IS TO MAINTAIN 1 FOOT CANDLE OF LIGHTING THROUGHOUT THE MEANS OF EGRESS PATH NOTE: NO FIRE ALARM SYSTEM THIS BUILDING WITH FIRE SPRINKLERS.	

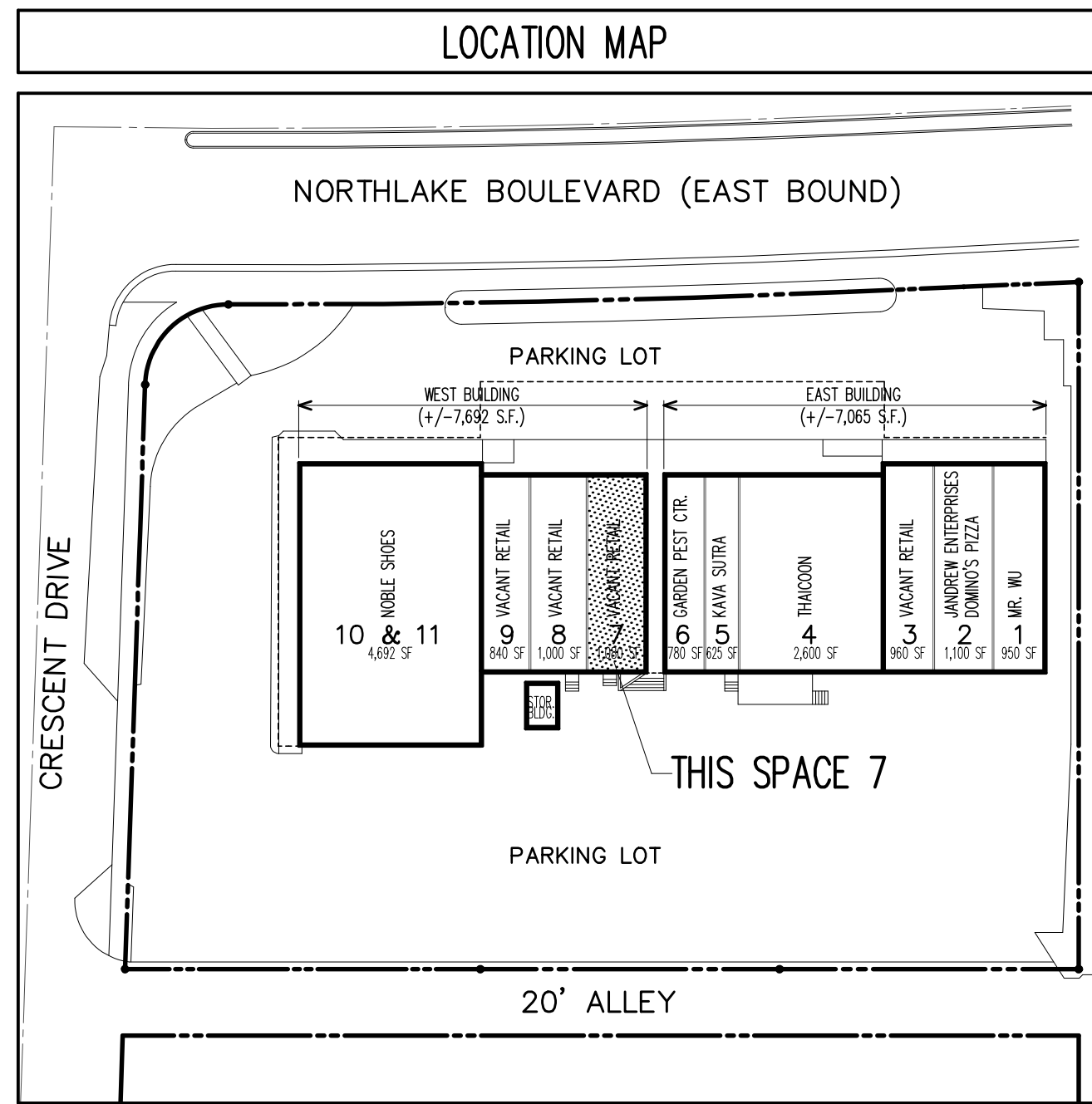
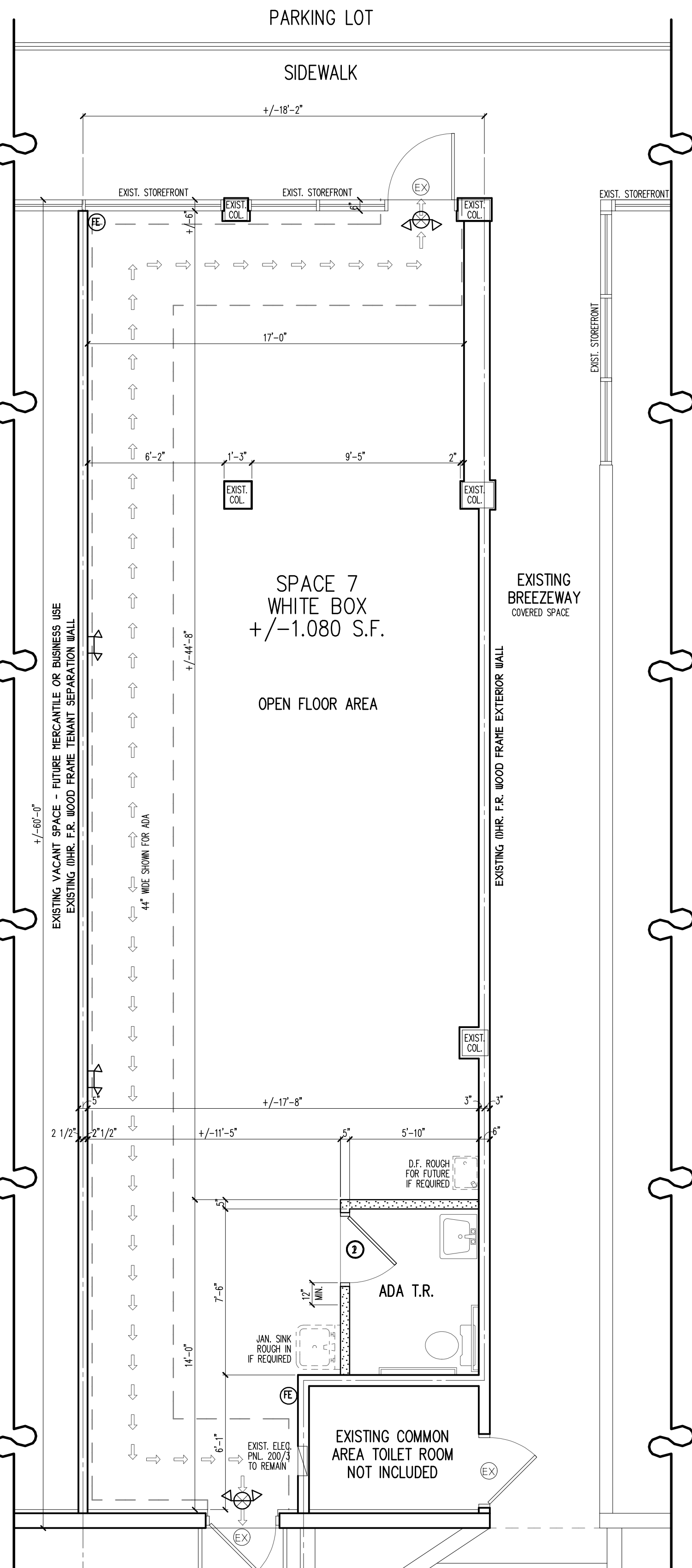

CODE REVIEW

PROJECT DESCRIPTION:
DEMO EXISTING SPACE FOR WHITE BOX SPACE – TENANT TO BE DETERMINED UNDER SEPARATE PERMIT

PROJECT DATA:
OCCUPANCY = GROUP M MERCANTILE (RETAIL / SALES AREA ON STREET FLOOR)
OR
OCCUPANCY = GROUP B BUSINESS

SPACE 7 = +/-1,080 S.F.
TOTAL OCCUPANT LOAD BASED ON FFPC TABLE 7.3.1.2 MERCANTILE (1 PER EVERY 30 S.F.) = 36 (EGRESS WORSE CASE)
TOTAL OCCUPANT LOAD BASED ON FFPC TABLE 1004.5 MERCANTILE (1 PER EVERY 60 S.F.) = 18
TOTAL OCCUPANT LOAD BASED ON FFPC TABLE 7.3.1.2 BUSINESS (1 PER EVERY 100 S.F.) = 11
TOTAL OCCUPANT LOAD BASED ON FFPC TABLE 1004.5 BUSINESS (1 PER EVERY 150 S.F.) = 8

PROPOSED USE:
TO BE DETERMINED – WHITE BOX – NO TENANT

APPLICABLE GOVERNING STANDARDS
ORIGINAL BUILDING CODE: BUILT IN 1962 1961 VERSION SOUTHERN STANDARD BUILDING CODE
PRESENT BUILDING CODE: FLORIDA BUILDING CODE 2020 – 7th EDITION
BUILDING (FBC-B), MECHANICAL (FBC-M), PLUMBING (FBC-P)
FLORIDA FIRE PREVENTION CODE (FFPC) 2020 – 7th EDITION
NATIONAL ELECTRIC CODE (NEC) 2017 EDITION

TYPE OF CONSTRUCTION:
TYPE III UNPROTECTED & UN-SPRINKLED BUILDING (1) STORY

EXIT REQUIREMENTS:
REQUIRED EGRESS CAPACITY PER NFPA 7.3.3.1 FOR LEVEL COMPONENTS AND RAMPS:
SPACE 7 (PRESENTLY A VACANT SPACE)
MERCANTILE (WORSE CASE) = 0.2" PER PERSON x 36 PERSONS = 8" (REQUIRED) 36" MINIMUM
(1) 36" DOORS IN FRONT PROVIDED & (1) 36" DOOR AT REAR
44" WIDE MINIMUM EXIT PATH SHOWN ON FLOOR PLANS TO COMPLY WITH ADA

DOOR & WINDOW NOTES

EXISTING DOORS TO REMAIN. VERIFY CONDITION & OPERATION ON SITE. REPAIR AS REQUIRED SEE PLAN NOTES AS TO ANY REVISIONS TO EXISTING.

36" x 80" x 1 3/4" SOLID CORE WOOD PRE-HUNG DOOR IN WOOD FRAME ADA APPROVED LEVER HARDWARE – PRIVACY LOCK AT TOILET ROOM VERIFY ALL LOCKING FOR OTHER DOORS AND HARDWARE PACKAGES WITH TENANT.

EXISTING EXTERIOR STOREFRONT WINDOWS TO REMAIN – NO CHANGE. CLEAN ALL GLASS AND FRAMES UPON FINAL INSPECTION, INSIDE & OUT. REPORT ANY DAMAGED UNITS TO ARCHITECT/OWNER FOR DIRECTION.

WALL SYMBOLS SCHEDULE

EXISTING EXTERIOR CMU WALLS. PATCH AS REQUIRED FOR NEW INTERIOR 5/8" G.W.B. FINISH W/ R-6 INSULATION BETWEEN 1 1/2" METAL FURRING – UP TO ROOF DECK, SAND & FINISH AS DIRECTED BY TENANT. CLEAN ALL WINDOW / DOOR GLASS AND FRAMES PRIOR TO FINAL.

EXISTING 2-HR. FIRE RATED INTERIOR CMU WALLS WITH FURRING & G.W.B. OVER (BOTH SIDES) PATCH & REPAIR AS REQUIRED TO MAKE RIGHT. SAND & PREP FOR FINISH. PAINT FINISH SELECTED BY TENANT.

EXISTING 1-HR. FIRE RATED INTERIOR WOOD STUD & G.W.B. TENANT SEPARATION WALL. PATCH & REPAIR AS REQUIRED TO MAKE RIGHT. SAND & PREP FOR FINISH. PAINT FINISH SELECTED BY TENANT.

EXISTING INTERIOR STUD PARTITIONS TO REMAIN. EXTEND TO ABOVE NEW CEILING LINE. PATCH & REPAIR AS REQUIRED TO MAKE RIGHT. SAND & PREP FOR FINISH. PAINT FINISH SELECTED BY TENANT.

NEW 3 5/8" METAL STUD (25ga.) PARTITIONS WALLS UP TO 10'-0" A.F.F. (ABOVE CEILING) STUDS 24" O.C. MAX. & 5/8" CYPRESS WALLBOARD FINISH SCREW ATTACHED EACH SIDE OF STUD. TAPE & SAND FOR PAINT FINISH SELECTED BY TENANT AND PER NOTES.

FLOOR PLAN – GENERAL NOTES

- CONTRACTOR TO NOTIFY PROPERTY MANAGER & TENANT OF ANY UNFORESEEN ISSUES, REPAIRS OR REPLACEMENTS REQUIRED IN THE FIELD AT THE START OF CONSTRUCTION.
- EXISTING STORE FRONT AND DOORS TO REMAIN. TENANT G.C. TO VERIFY CONDITIONS AND REPAIR AS NEEDED.
- PROVIDE 2"x6" P.T. WOOD BLOCKING IN ALL WALLS WHICH ARE DESIGNATED TO HAVE ACCESSORIES, PLUMBING, ETC. AS TYPICAL BLOCKING IF STUD FRAMED WALLS.
- CONTRACTOR TO FURNISH AND INSTALL (2) 5# ABC FIRE EXTINGUISHER AT LOCATION DESIGNATED ON PLAN OR FIRE INSPECTOR. OBTAIN TAG/CERTIFICATION BY LOCAL AUTHORITY IF REQUIRED.
- TENANT'S GENERAL CONTRACTOR TO SUPPLY AND INSTALL 2' x 2' x 5/8" PLYWOOD BACKER BOARD FOR NETWORK EQUIPMENT. BACKER BOARD TO BE PAINTED TO MATCH WALLS – GLUE AND SCREW INTO STUDS, INSTALL WITH BOTTOM OF BACKER BOARD @ 6'-0" A.F.F. SEE FLOOR PLAN AND ELECTRICAL PLAN FOR LOCATION.
- FIELD VERIFY ALL DIMENSIONS WITH EXISTING BUILDING CONDITIONS.
- PATCH ALL DISTURBED SURFACES TO MATCH EXISTING

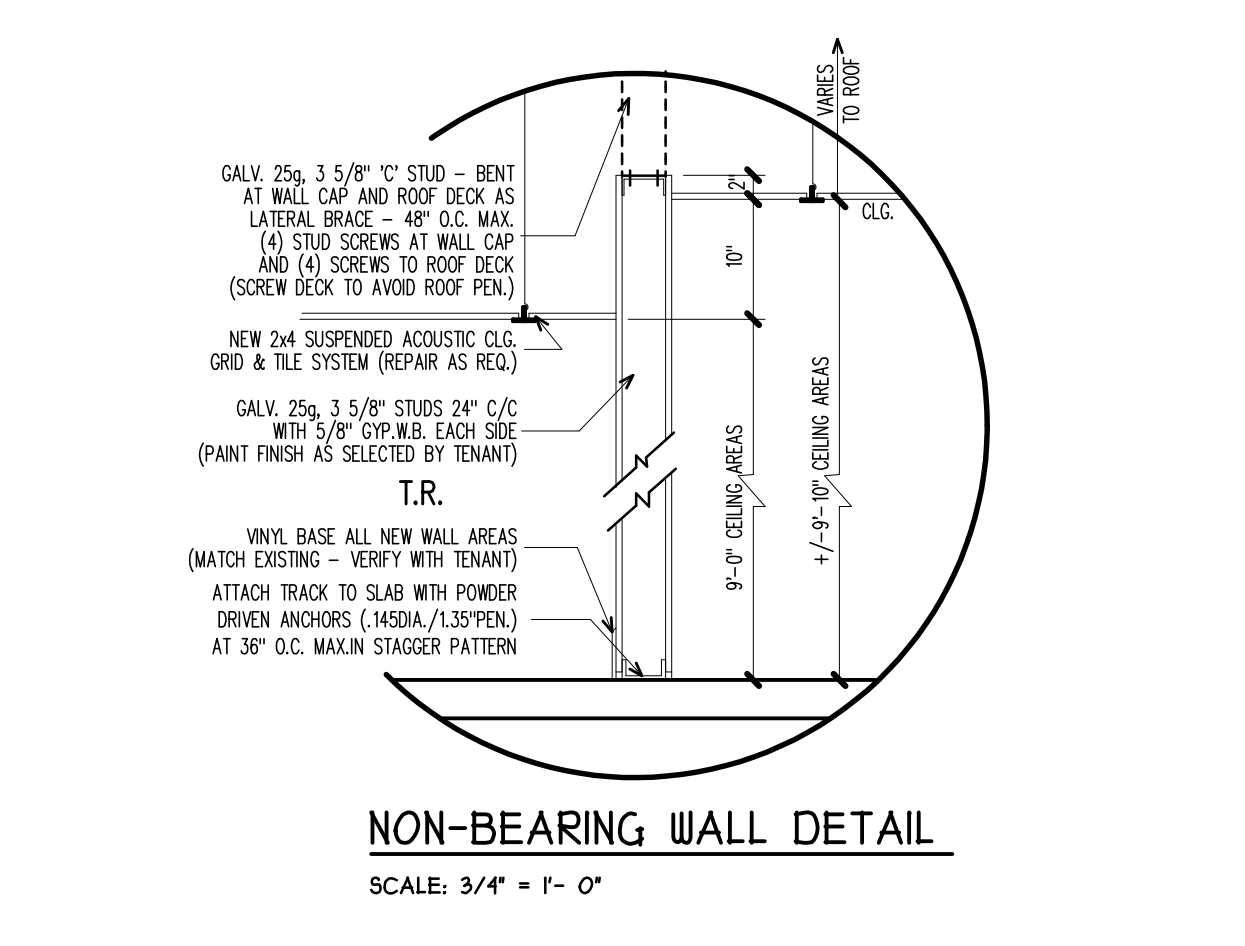
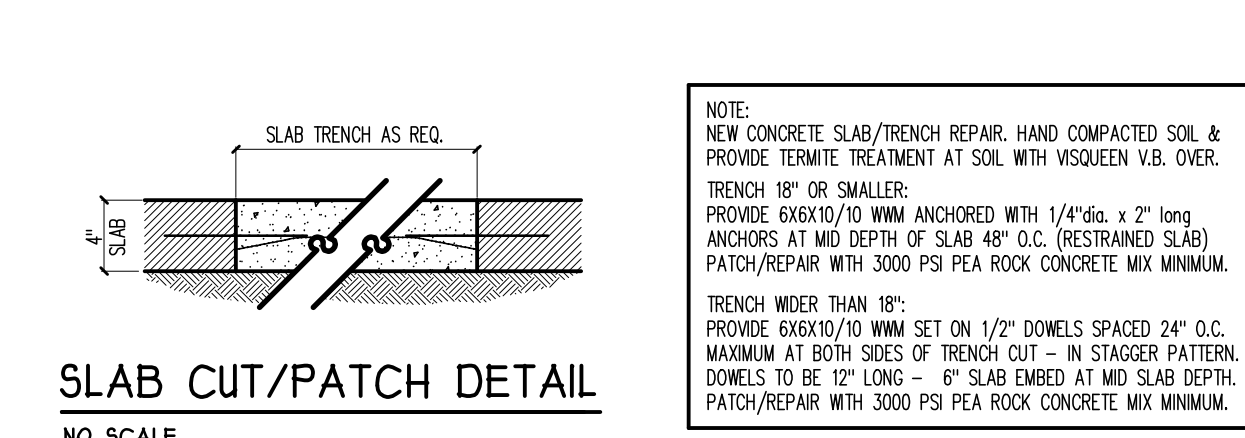
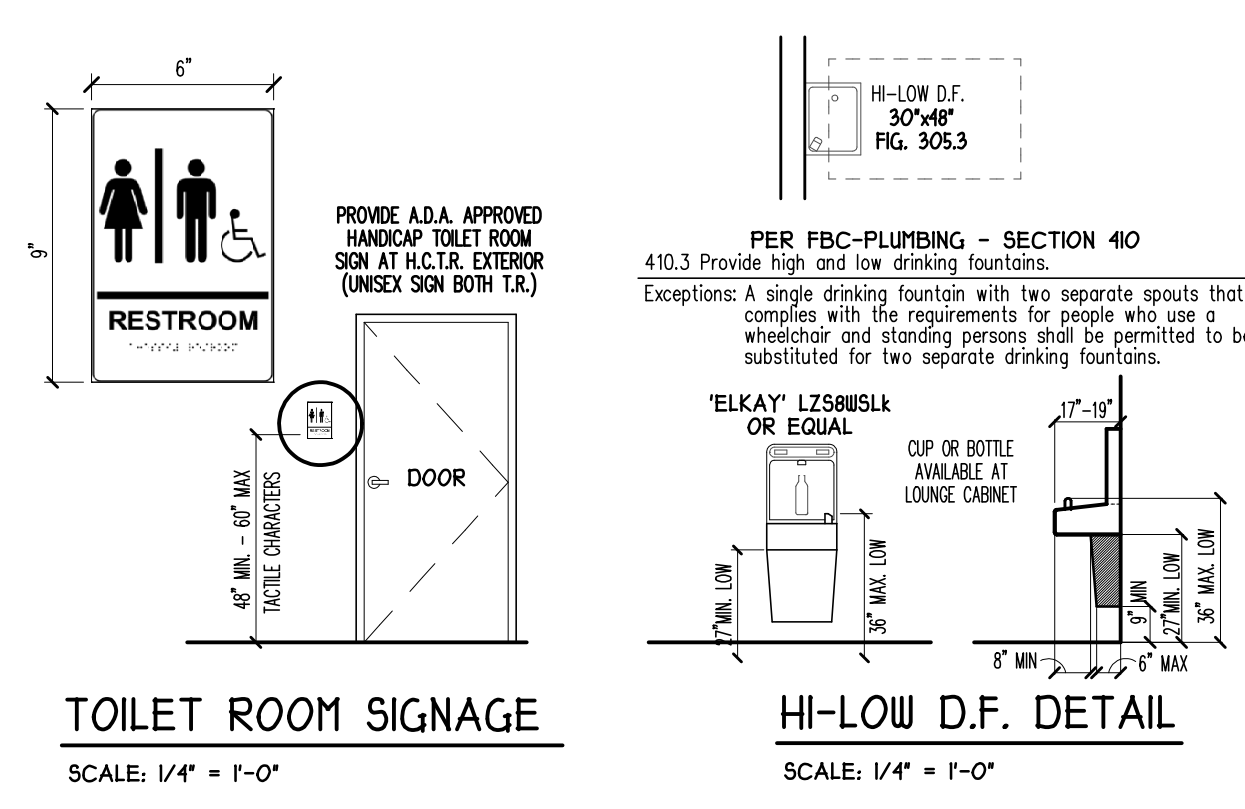
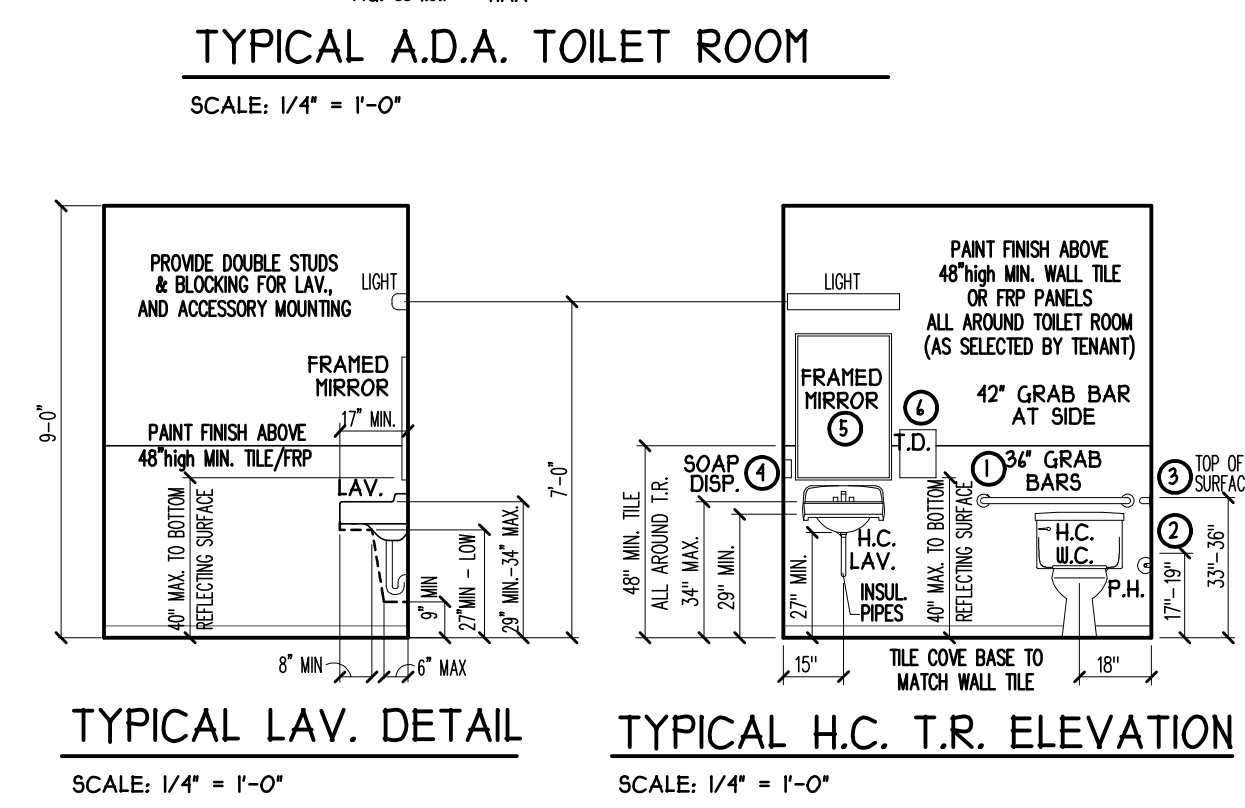
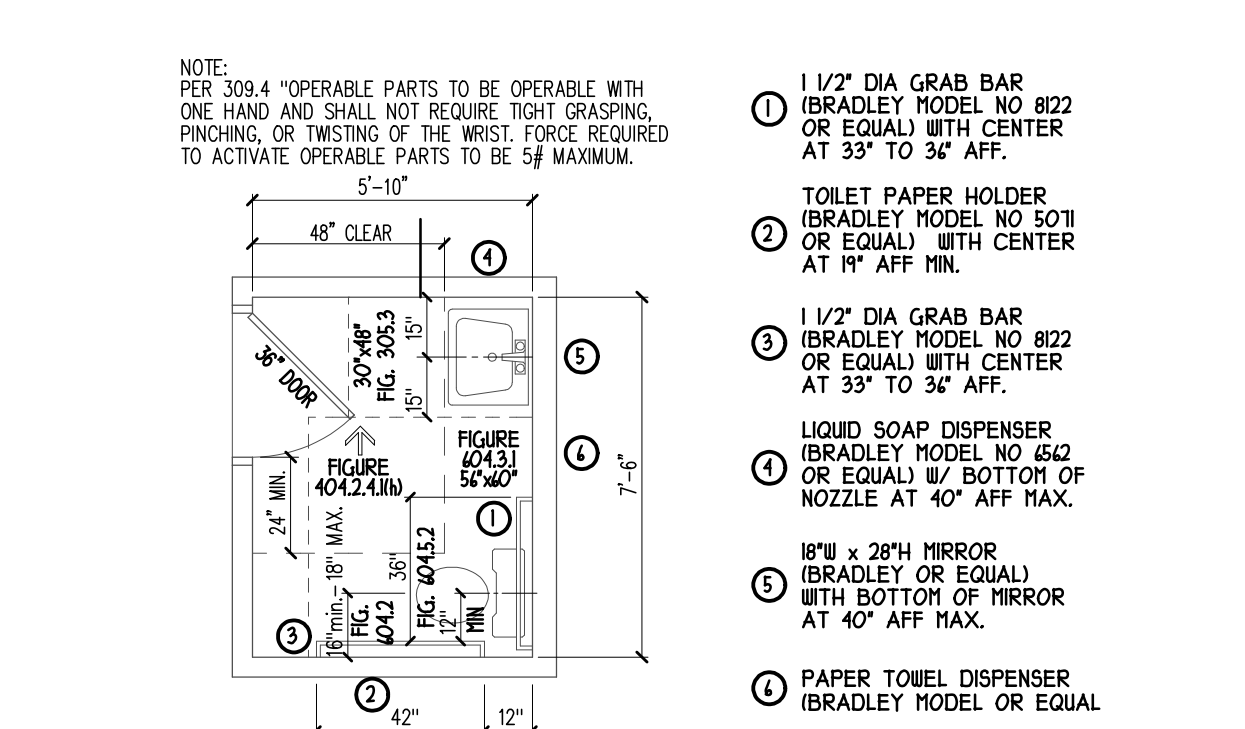

DEMOLITION PLAN NOTES

- DO NOT DISTURB ADJACENT TENANTS WITH NEW CONSTRUCTION, AS WELL AS FOLLOW RULES OF THE PROPERTY MANAGER, INCLUDING ALLOWED WORKING HOURS AND NOISE REGULATIONS.
- DO NOT DISTURB COLUMNS/FOUNDATION/ROOF STRUCTURE PRIOR TO APPROVAL FROM ENGINEER OR ARCHITECT. REPORT TO ARCHITECT ANY ISSUES OF CONCERN FOR EXPOSED STRUCTURE.
- MAINTAIN ALL FIRE SAFING AT EXISTING TENANT PENETRATIONS. MAINTAIN FIRE ALARM SYSTEM.
- PULL ALL ELECTRICAL WIRES AT ABANDONED ELEC. BACK TO PANEL TO REMAIN (NEW BREAKERS)
- ABANDON NOTED PLUMBING WATER & WASTE LINES. CAP OFF AS REQUIRED.
- REMOVE ALL FLOORING AND PROVIDE SMOOTH CLEAN SLAB FOR FUTURE TENANT FINISH.
- REMOVE ALL INTERIOR WALLS EXCEPT FOR TENANT SEPARATION AND PERIMETER WALL FINISH.
- REMOVE ALL CEILING AND CEILING SUPPORT STRUCTURE / WIRES.
- REMOVE ALL DUCT WORK BACK TO RTU TO REMAIN. CONDENSATE LINES & RTU TO BE SERVICED.
- BROOM CLEAN ENTIRE SPACE

RESTROOM REQUIREMENTS

PLUMBING CODE – TABLE 403.1 – "MINIMUM PLUMBING FIXTURES"

GROUP	WHITE BOX – SHELL SPACE 7 * 1,080 S.F. GROSS	GROUP "B" – BUSINESS 8 OCCUPANTS (PER FBC)	WATER CLOSET	LAVATORY	DRINKING FOUNTAINS	SERVICE SINK (e)
REQUIRED FIXTURES	SEPARATE FACILITIES SHALL NOT BE REQUIRED IN MERCANTILE OCCUPANCIES IN WHICH THE MAXIMUM OCCUPANT LOAD IS 100 OR FEWER.	SEPARATE FACILITIES SHALL NOT BE REQUIRED IN BUSINESS OCCUPANCIES IN WHICH THE MAXIMUM OCCUPANT LOAD IS 25 OR FEWER.	MERCANTILE 1	1	1	1
PROVIDED FIXTURES	PER TABLE 403.1 FOOTNOTE (e) FOR BUSINESS & MERCANTILE OCCUPANCIES WITH AN OCCUPANT LOAD OF 15 OR FEWER, SERVICE SINKS SHALL NOT BE REQUIRED.	PER SECTION 410.2 "SMALL OCCUPANCIES" – DRINKING FOUNTAINS SHALL NOT BE REQUIRED FOR AN OCCUPANT LOAD OF 15 OR FEWER.	MERCANTILE 1	1	1	1

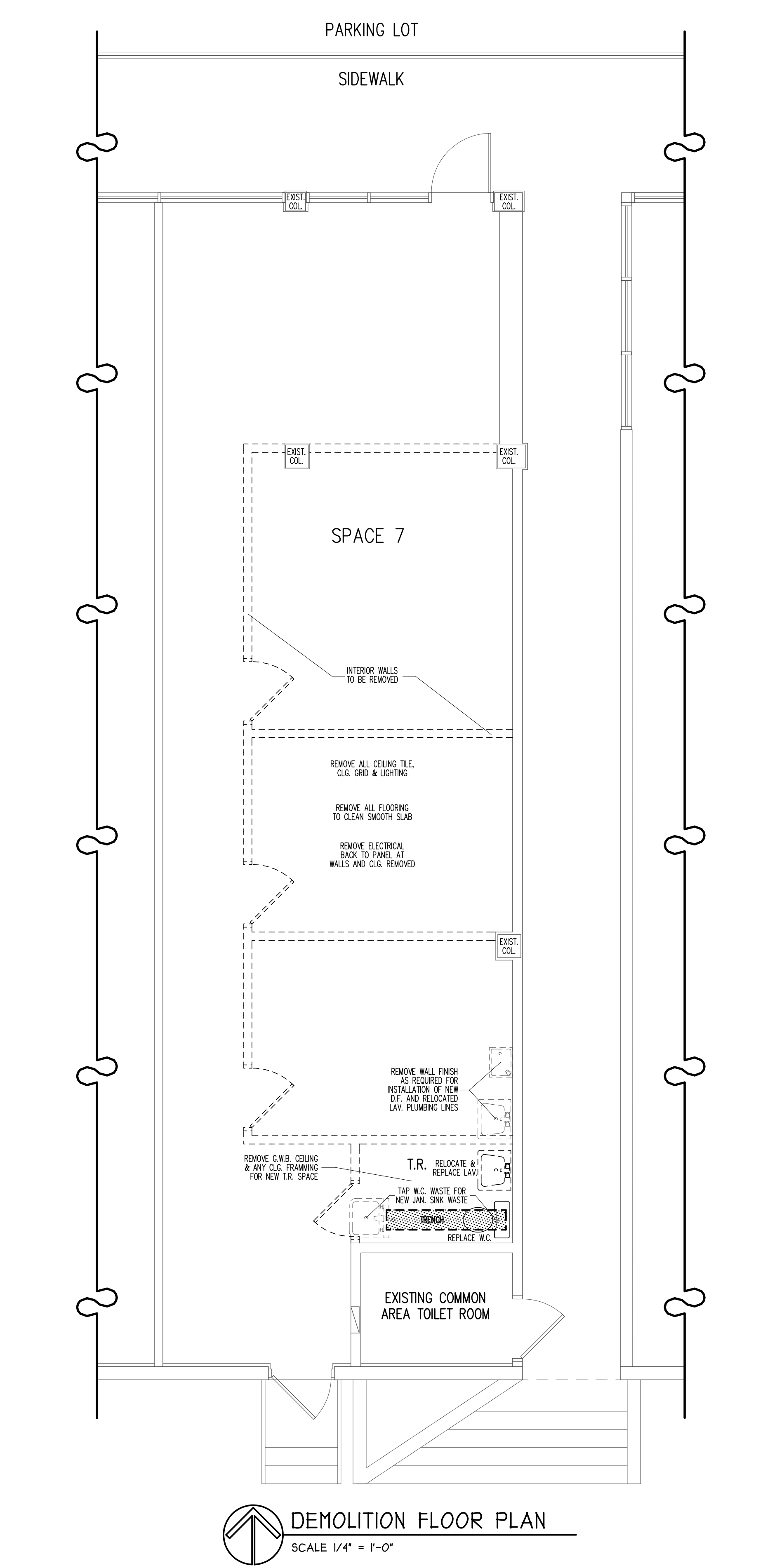

REVISIONS:

JMS ARCHITECTURAL DESIGN INC.
PLANNING & CONSULTING
16106 75th AVENUE N. * PALM BEACH GARDENS, FL 33418
TEL: (561) 745-2120 FAX: (561) 745-1707 E-MAIL: jdesign@aol.com

THIS AND SPECIFICATIONS ARE THE PROPERTY OF JMS ARCHITECTURAL DESIGN INC. NO REPRODUCTION OR DISTRIBUTION OF ANY KIND IS PERMITTED WITHOUT WRITTEN PERMISSION. PLEASE REFRAIN FROM MAKING ANY COPIES OR REPRODUCTIONS OF ANY KIND WITHOUT WRITTEN PERMISSION. ALL RIGHTS RESERVED.

DEMOLITION & WHITE BOX CONVERSION FOR:
SPACE 7 * 450 NORTHLAKE PLAZA
450 NORTHLAKE BOULEVARD * LAKE PARK, FLORIDA 33403
PALM BEACH COUNTY PCN 98-43-42-21-03-140-0010

STATE OF FLORIDA
MICHAEL E. SIPULA
REGISTERED ARCHITECT
AR0011026

DATE: 11-27-23 PROJECT #: 23012.7
A.1 / DEMO