

# Modern Offices to Rent

7.295 sq. m. (2,034 sq. ft.) approx. • £20.00 per sq. ft., per year



4/6 Trinity Chare, Trinity Courtyard, Broad Chare, Newcastle upon Tyne NE1 3DF

Quality self-contained offices to let in a unique historical building and setting within the courtyard of the Newcastle upon Tyne Trinity House.



# Location

Gallery & Virtual Tour

**4/6 Trinity Chare is located in the quiet Trinity House Courtyard, off Broad Chare, close to the Newcastle Crown and Commercial Courts. Easily accessible from Newcastle Quayside and Gateshead Quays, the city's most successful commercial mixed-use business locations with dramatic views of the River Tyne gorge.**

4/6 Trinity Chare is close to the amenities within the historic Quayside area of the city and a short walk to the City Road Multi-Storey Car Park.

There are good bus links providing an efficient public transport for visitors and staff to the city centre, the regional Metro Rapid Transit System 'the Metro', and Newcastle Central Station with ongoing connections to the regional and national East Coast mainline, to Newcastle International Airport, Durham and Sunderland City Centre's.

Newcastle City Centre provides excellent shopping, restaurants and bars, leisure and entertainment facilities, including theatres and located a few minutes' walk across the river in Gateshead, the Glasshouse International Centre for Music, Baltic Centre For Contemporary Art, with the proposed construction of The Sage International Conference Centre the UK's newest International Conference, Exhibition Centre and Arena Venue.

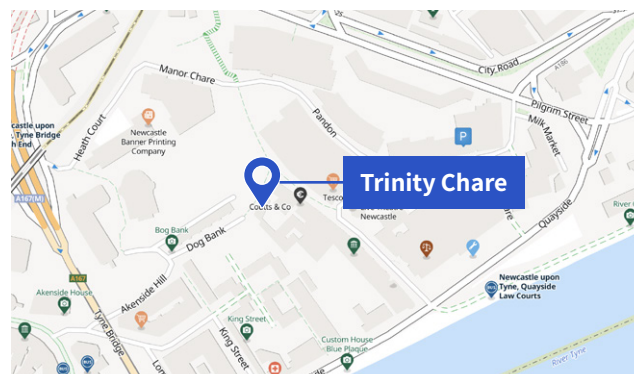

**In a convenient location for access to local amenities, travel time by car is approximately:**

- 10 minutes (13 min walk)** Newcastle upon Tyne Central Station, East Coast Mainline
- 5 minutes (13 min walk)** The Glasshouse International Centre for Music and the Baltic Centre for Contemporary Art
- 13 minutes** MetroCentre
- 20 minutes** Newcastle International Airport

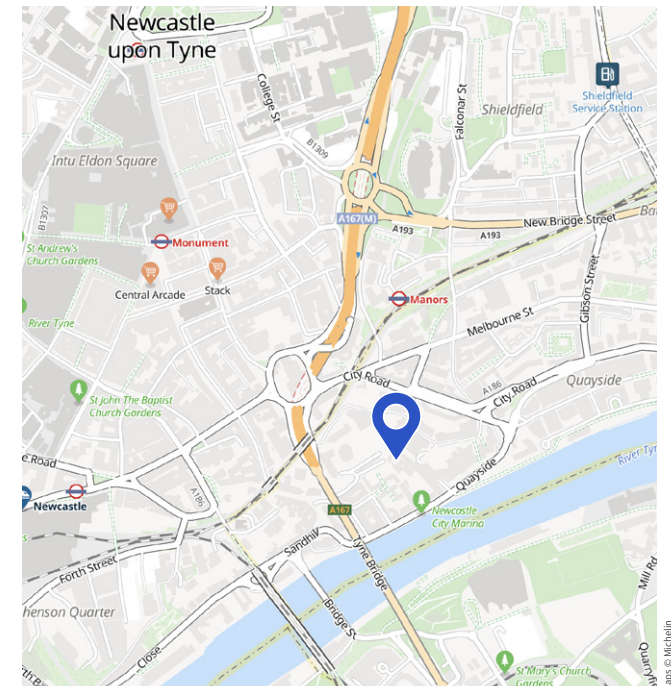

# About Trinity Chare

Gallery & Virtual Tour

**There has been a complete redesign of the interior finishes, retaining the character of this ancient building provides offices to Grade A standard of some 2,034 sq. ft. over three floors.**

Trinity House, Newcastle upon Tyne, came into being on 4th January 1505, as a charitable guild to support the City's growing maritime community and their dependents.

Securing some land, previously known as Dalton's Place, in Broad Chare on Newcastle's Quayside, comprising a Merchants House, now known as 4/6 Trinity Chare, and warehousing to the banks of the River Tyne. It is likely that the Merchant's House was built in the 14th century.

The concept designs is to fitout the building to provide modern office accommodation, within the courtyard setting. The Trinity House is an estate of listed buildings of architectural and historic interest with chapel, banqueting rooms and offices, occupied as barristers' chambers. For more interest in Trinity House Newcastle [visit this link](#).

Trinity House can provide unique event space in the Banqueting, Board and Meeting Rooms and outdoor space, by arrangement.



## Accommodation

Approx	Sq. m.	Sq. ft.
Ground Floor	52.72	567
First Floor	64.18	691
Second Floor	72.10	776
<b>Total Net</b>	<b>189.00</b>	<b>2,034</b>

## Specification

- Self-contained building
- Quality finishes and furnishings
- Flexible open plan floor plates
- Highly efficient heating and cooling
- Featured led lighting
- Perimeter trunking for power and IT
- Modern tea point
- High quality wc's
- No parking on site, public MSCP nearby

## Ground Floor

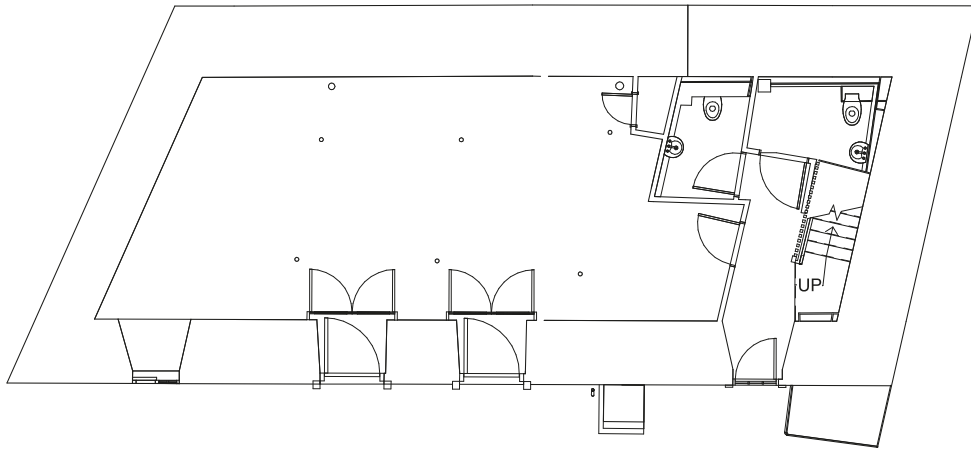

## First Floor

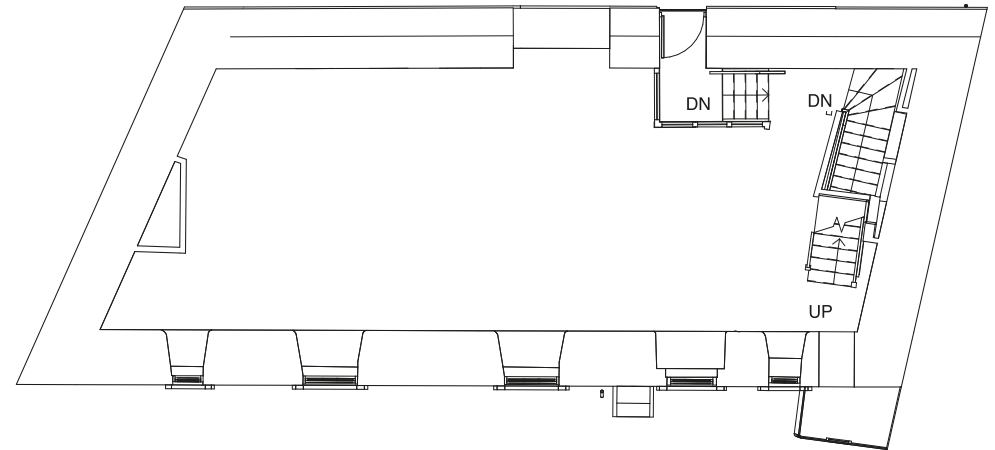

## Second Floor

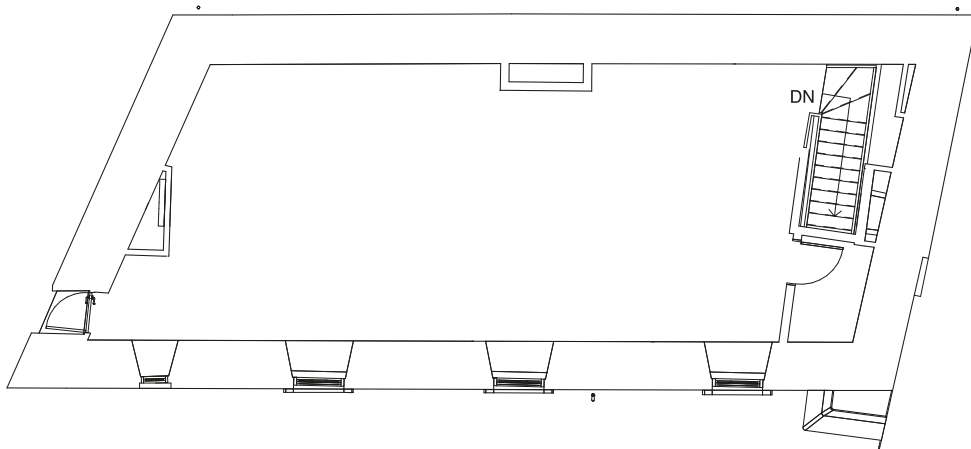

# Further Details

Gallery & Virtual Tour

## Leased Terms

Offered on an effective full repairing and insuring lease for a term to be agreed.

## Energy Performance Certificate

Estimated B.

## Business Rates

- Rateable Value £21,500 appearing in the valuation list.
- Small Business Rate 49.9 p in £ (2025/2026).
- Amount payable £10,728.50 p.a. / £894.05 p. m. equivalent to £5.27 per sq. ft.
- The rateable value may obtain taper relief depending on your circumstances. Check eligibility and apply for relief via Newcastle City Council's [business rates portal](#).

## Service Charge

There is a service charge for the upkeep of the courtyard and security/fire alarm systems, when costs are incurred.

## Value-Added Tax

All rents, premiums and purchase prices quoted are exclusive of VAT. All offers are to be made to the sole letting agents JK Property Consultants LLP, on this basis and where silent, offers will be deemed net of VAT.

## Money Laundering Regulations

To comply with the UK government Money Laundering Directive counterparty on agreement of heads of terms due diligence will be required on a company or individual(s) intending to take a lease for the subject property.

## Code of Practice

The landlord accepts the principles of the Code of Practice for the Commercial Leases in England and Wales. Alternative lease terms are available upon request. A copy of the Code can be obtained from Royal Institution of Chartered Surveyors, 12 Great George Street, Parliament Square, London SW1P 3AD Tel: 0207 695 1535.



For Further Information and Viewing Please Contact Us:



**Kevan Carrick**

BSc (Est Man) FRICS

📞 07957 811 824

✉ kevan@jkpropertyconsultants.com

**Jennifer Welch**

📞 07808 138 255

✉ jennifer@jkpropertyconsultants.com

**Important Notice:** These particulars are not an offer or contract, nor part of one. What rely on statements by JK Property Consultants LLP in these particulars or by word-of-mouth or in writing as been factually accurate about the property, its condition, or its value. JK Property Consultants LLP has no authority to make any representations about the property, and accordingly any information given is entirely without responsibility on the part of the agent, seller, or lessors. The photographs show only certain parts of the property as they appeared at the time they were taken. Areas, measurements, and distances given are approximate only. Any reference to alterations to, or use of, any part of the property does not mean that any necessary planning, building regulations or other consent has been obtained. A buyer or lessee must find out by inspection or in other ways that these matters have been properly dealt with and that all information is correct. The VAT position relating to the property may change without notice. JK Property Consultants LLP is a limited Liability partnership registered in England with registered number 0C333126. JK Property Consultants LLP registered office is 1 Trinity Chare, Broad Chare, Newcastle upon Tyne NE1 3DF where you may look at a list of members' names. October 2025.