

PRIME LEASING OPPORTUNITY AVAILABLE



# Bonavista Promenade Shopping Centre

755 Lake Bonavista Drive SE  
Calgary, AB



CBRE

# Demographics

---



**55,472**

Population Within 3 KM



**\$160,375**

Average Household  
Income Within 3 KM



**32%** of population aged between  
**20 - 44 Years**  
Within 3 KM

## Prime retail opportunity in a modern enclosed mall

- Modern suburban enclosed mall with ample parking.
- Anchored by Safeway with other tenants including Shoppers Drug Mart, TD, Circle K, Subway, Little Caesars and Brewsters.
- This neighborhood mall provides an excellent opportunity to foster and grow a business in an established and busy mall.
- Servicing the Communities of Lake Bonavista, Willow Park, Canyon Meadows, Queensland and Deer Run.

### Space Available

Unit 131 - 962 sq. ft.

Unit 127 - 6,154 sq. ft.

Unit 169 - 937 sq. ft.

Unit 175 - 1,774 sq. ft.

---

BASIC RENT - Market

OP COSTS & TAXES - \$22.56 + Mgmt Fee (2026)

SIGNAGE - Fascia

POSSESSION - Unit 131 - Immediate

Unit 127 - April 1, 2026

Unit 169 - Immediate

Unit 175 - Immediate

ZONING - DC

TERM - 5 - 10 years



# Leasing Plan

## Main Floor



# Unit 131 - Photos



# Unit 127 - Photos and Floor Plan

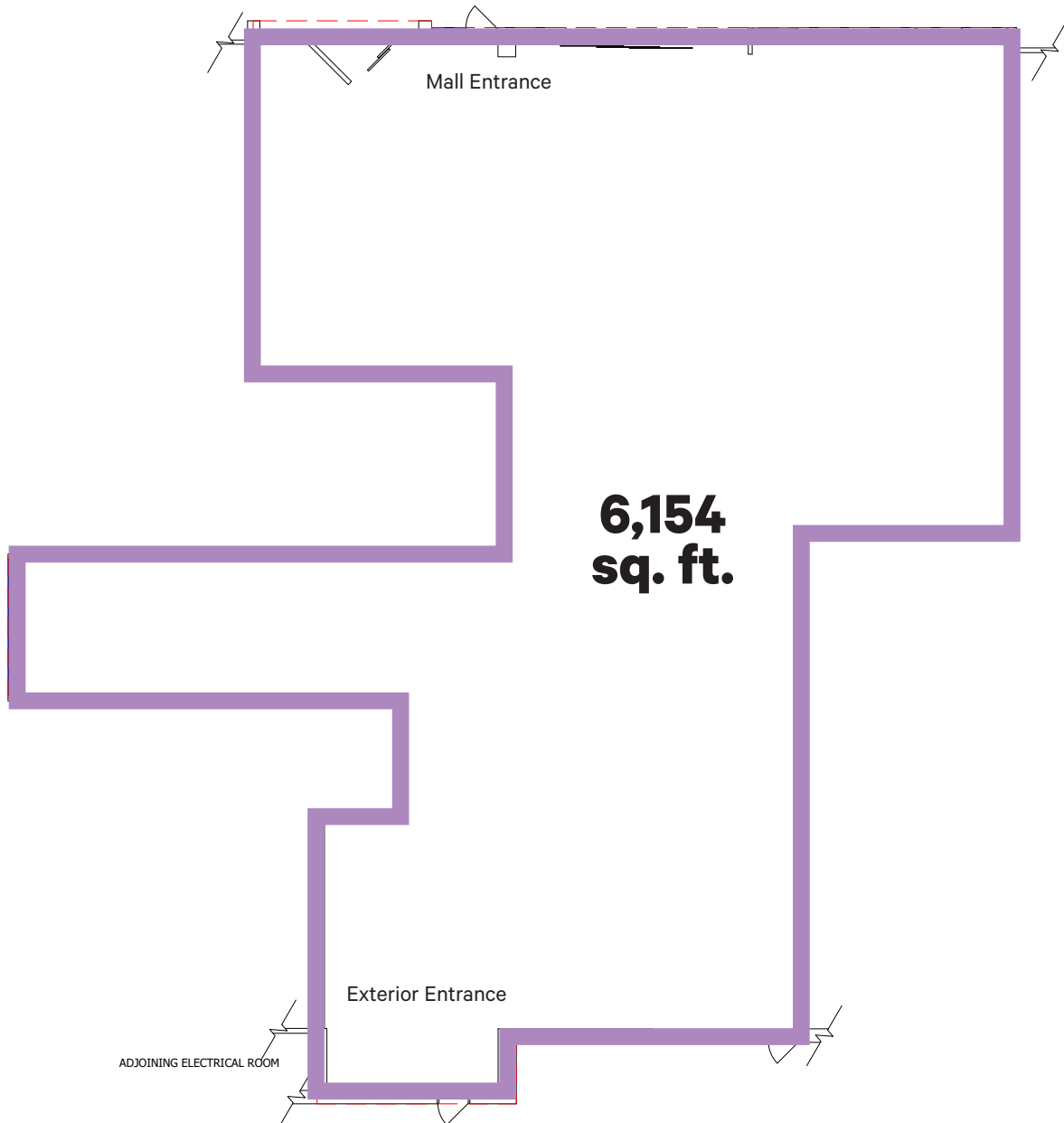

# Unit 169 - Photo and Floor Plan



# Unit 169 - Floor Plan

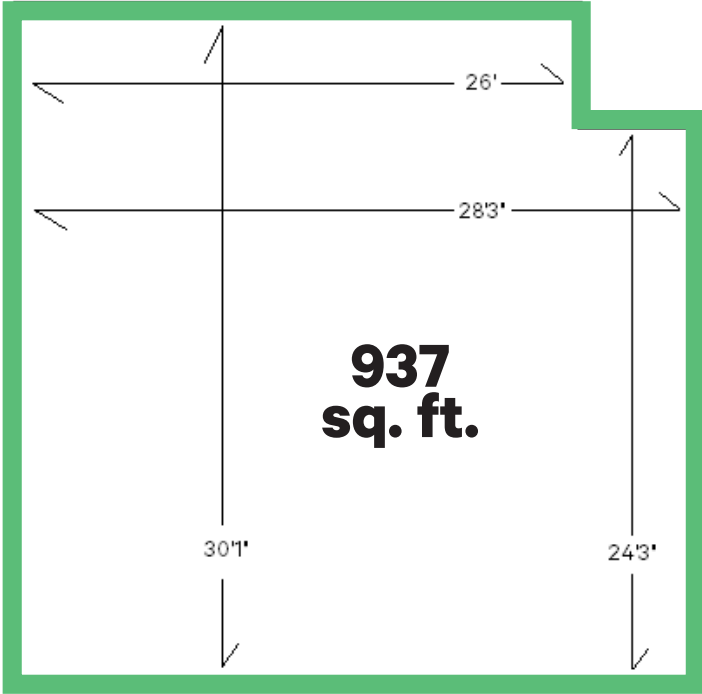

# Unit 175 - Photos



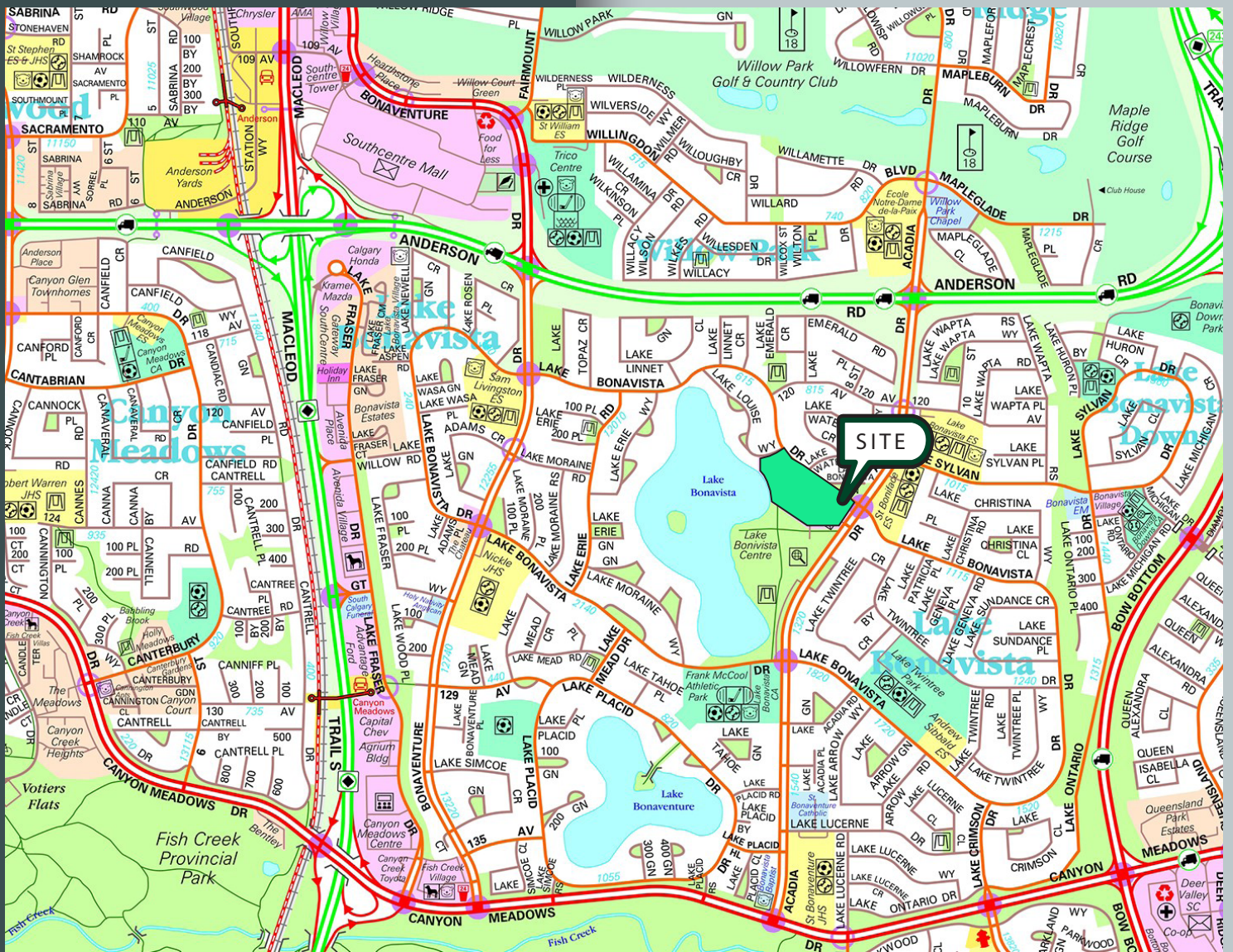

For More Information Please Contact

**Alistair Corbett**

Senior Vice President  
403.294.5709  
alistair.corbett@cbre.com

**Cory Miles**

Senior Sales Associate  
403.750.0523  
cory.miles@cbre.com

**Mac Marcinew**

Sales Associate  
587.583.7197  
mac.marcinew@cbre.com

**Jayne Rogers**

Transaction Manager  
403.750.0535  
jayce.rogers@cbre.com

**Brandy Chorney**

Marketing Specialist  
403.303.3609  
brandy.chorney@cbre.com

CBRE Calgary

Eighth Avenue Place

East Tower 525 8 Avenue SW Suite 3200

Calgary, Alberta T2P 1G1

This disclaimer shall apply to CBRE Limited, and to all divisions of the Corporation ("CBRE"). The information set out herein (the "Information") has not been verified by CBRE, and CBRE does not represent, warrant or guarantee the accuracy, correctness and completeness of the Information. CBRE does not accept or assume any responsibility or liability, direct or consequential, for the Information or the recipient's reliance upon the Information. The recipient of the Information should take such steps as the recipient may deem necessary to verify the Information prior to placing any reliance upon the Information. The Information may change and any property described in the Information may be withdrawn from the market at any time without notice or obligation to the recipient from CBRE. Mapping Sources: Canadian Mapping Services canadamapping@cbre.com; DMTISpatial, Environics Analytics, Microsoft Bing, Google Earth. Map© 2024 Sherlock Publishing Ltd.

