



For Lease

106 N 6th Street

Flagship Retail Space | 2,500 SF

MRG
Momentum Realty Group

Property Details

106 N 6th St

OVERVIEW

ADDRESS	106 N 6th St, Brooklyn, NY 11211
CROSS STREETS	N 6th St and Berry St
NEIGHBORHOOD	Williamsburg

SPACE DETAILS

TOTAL SF	2,500 sq ft
CEILING HEIGHT	12 ft
FRONTAGE	25 ft
CONFIGURATION	Flagship Retail Space

HIGHLIGHTS

- 22 ft wide Glass Frontage with Floor-to-Ceiling Windows
- 10'4 ft Ceilings with Spotlights Throughout
- HVAC and ADA Restroom Already in Place
- Polished Concrete Floors and Vanilla - Boxed Condition
- Stunning Archways Create Natural Divisions Throughout the Space
- Basement Storage Included
- Open Canvas Allowing Tenants to Customize and Design to their Needs

NEIGHBORS



More Than Brokers.
Trusted Partners.

Floor Plan

106 N 6th St

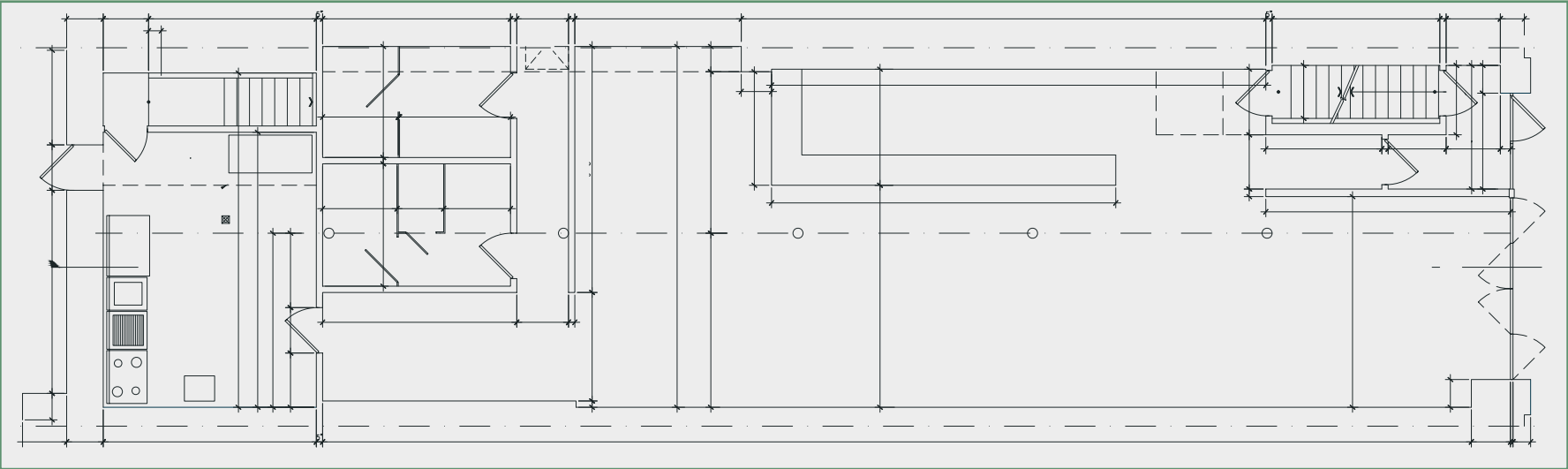

Ground Floor

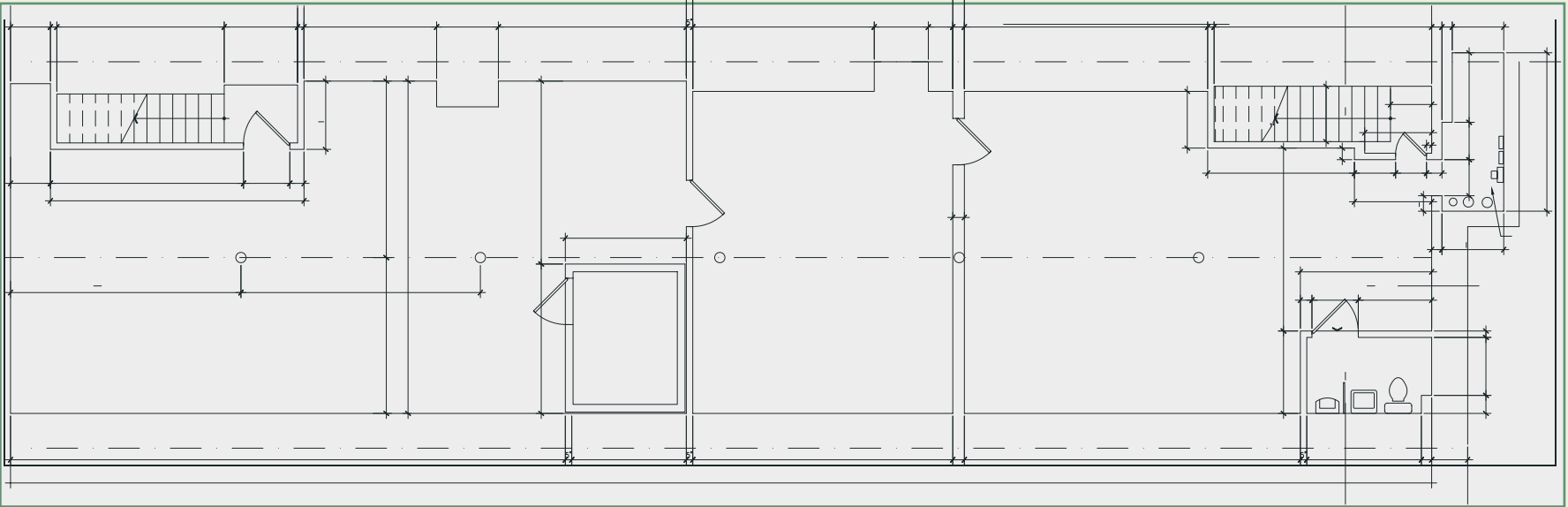

Basement

Floor plan is representational. Dimensions subject to field verification.

Location

106 N 6th St

TRANSPORTATION



B62, B32 Buses

2 min walk to bus lines



Train L

4 min walk to subway



LGA Airport

17 min drive

JFK Airport

26 min drive

EWR Airport

35 min drive

DEMOGRAPHICS



Population

146,193



Median Household Income

\$142,338



Median Home Value

\$1,029,338



Interior Images

106 N 6th St



Neighborhood Map

106 N 6th St





106 North 6th Street

106 N 6th St,
Brooklyn, New York 11211
2,500 sq ft · For Lease

ENQUIRIES

To arrange a showing or discuss leasing terms, please reach out to one of our agents directly.

Solomon Betesh

Solb@mrgny.com
212-314-4684 · Ext. 111

Avi Akiva

Avi@mrgny.com
212-314-4684 · Ext. 101

Eddie Keda

Eddie@mrgny.com
212-314-4684 · Ext. 104

Jonathan Lib

Jonathan@mrgny.com
212-314-4684 · Ext. 114

All information supplied in this marketing presentation and/or flyer is from sources deemed reliable and is furnished subject to errors, omissions, modifications, removal of listings from sale/lease and to any listing condition. Any square footage, dimensions, floor plans and/or technical data set forth are approximations and are subject to further elaboration/confirmation.