



SPACE
THAT
WORKS

THE
LAMBOURN
ABINGDON



THE
LAMBOURN

ASHDON

THE
LAMBOURN

ASHDON

The building is
open to all
and is a
great place
to work

ASHDON

A HOME FOR YOUR BUSINESS

Introduction

Situated on a prominent position with good transport links lies The Lambourn, a detached 3 storey premium business HQ building providing various suites sizes arranged in two wings with a central full height reception.

The Lambourn is a completely refurbished business and research building providing high specification office accommodation, amenities with a staffed reception within an attractive full height atrium. The building provides the perfect environment for companies requiring flexible business and research space.

Situated on the Western edge of the town, The Lambourn lies within a prominent position of Abingdon Business Park which comprises of 50 acres of office, industrial and retail warehouses accommodation. This premier business location houses a number of headquarters which include Giga Clear, Smeg and Miele.

The Lambourn is easily accessible being situated 1 mile from the A34 Abingdon Interchange, leading to the M40 (18 miles) north and the M4 (17 miles) South. Both motorway links connect with London, Birmingham and the Southwest.

Public transport options include rail links via Oxford and Didcot (10 miles) providing routes to London Paddington, Bristol Temple Meads and Birmingham New Street. A number of local bus routes are within a 6 minute walking distance from The Lambourn.



LOCATION

Located in the economic & knowledge corridor



Spot On Location

- Prominent corner position on established business park.
- Abingdon is home to Abingdon Business Park and Abingdon Science Park.
- Town centre and associated amenities within 15 minutes' walk
- World renowned city of Oxford less than 6 miles (10km) away.



Linked in to Transport

- A34 junction access less than 1 km (0.6 miles).
- Mainline train stations at Oxford and Didcot are located within 5 miles (8 km).
- Local stations of Culham and Radley less than 3 miles (5 km) east.
- Local Bus stops on Colwell Drive (250m away)



Be part of the Abingdon Cluster

Nearby occupiers include

- Gigaclear
- Smeg
- Sophos
- PsiOxus Therapeutics
- Berkshire and Bucks FA
- Thames Valley Police



Unrivalled Amenities

- **Food & Beverage** Subway, McDonalds.
- **Leisure** Anytime Fitness, Albert Park.
- **Hotels** Four Pillars Hotel and Premier Inn.
- **Convenience Stores** Tesco and Waitrose.

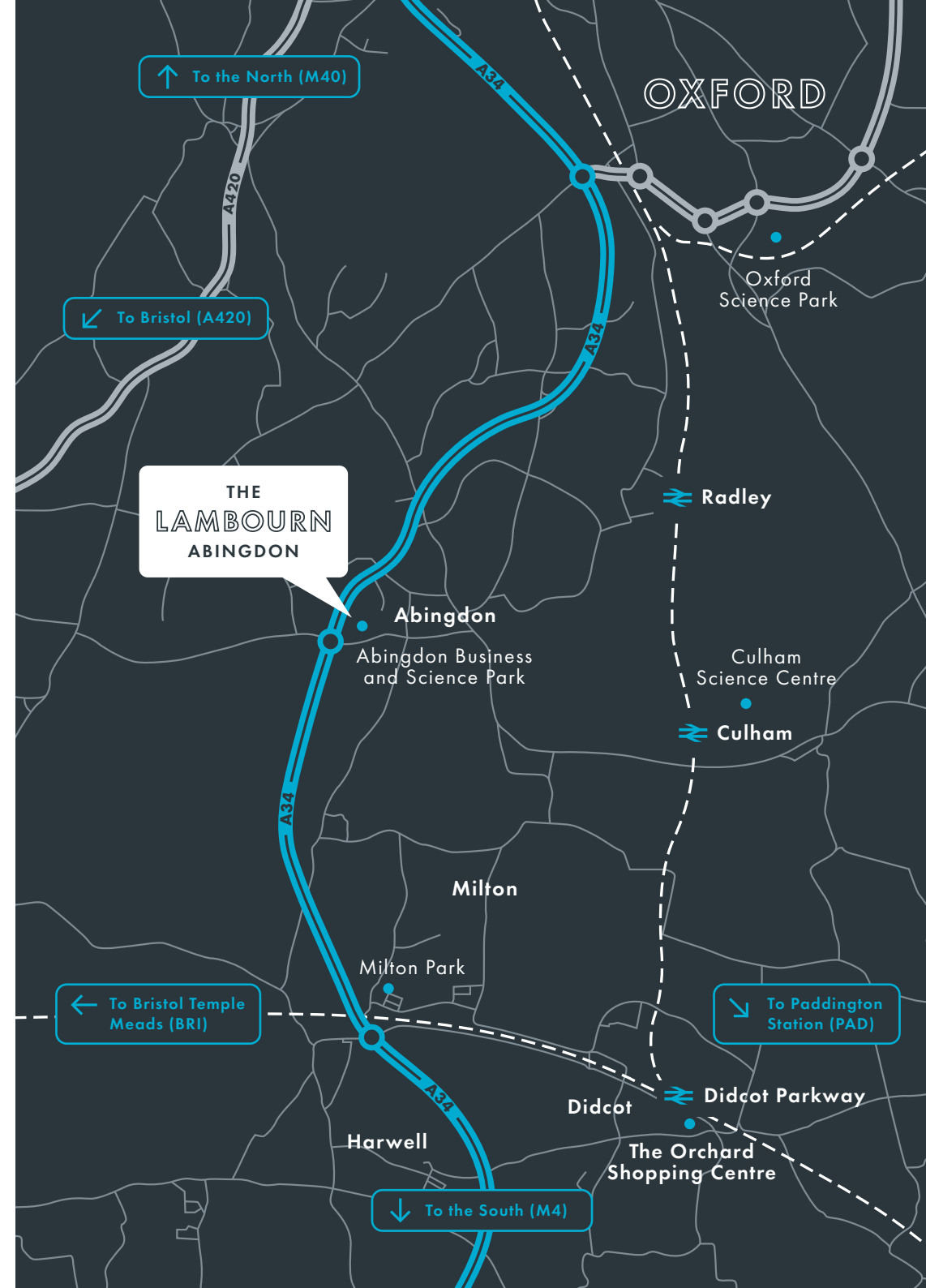
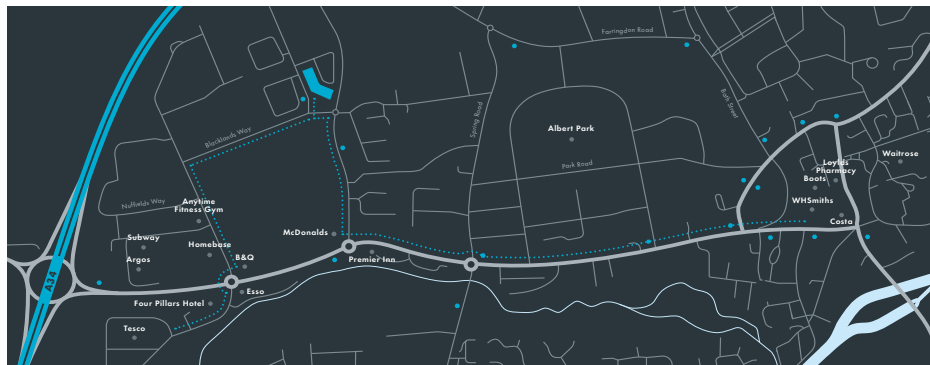

FLOOR PLANS

SPACE	SQM/SQFT
GROUND	
WEST WING	830.8/8,943
EAST WING	LET
FIRST	
WEST WING	LET
EAST WING - SUITE A	177.2/1,907
EAST WING - SUITE B	LET
SECOND	
WEST WING	867.9/9,342
EAST WING - SUITE A	LET
EAST WING - SUITE B	152/1,636

Flexibility

Smaller suites from approximately 2,000 sq. ft. are also available as well as co-working and flexible serviced options.

Bespoke fitted solutions also available to suit exact requirements, with a range of flexible payment structures.

Building Features

- New feature entrance
- Triple height manned reception/lobby
- High efficiency boilers
- Modernised electrical system
- Fully air conditioned
- Motion sensor LED lighting
- Fully access raised floor (2800mm)
- Parking for up to 215 cars
- Covered bicycle racks
- 2 x passenger lifts
- High quality shower facilities
- Co-working breakout space available
- EPC B (50) Rating

Ground

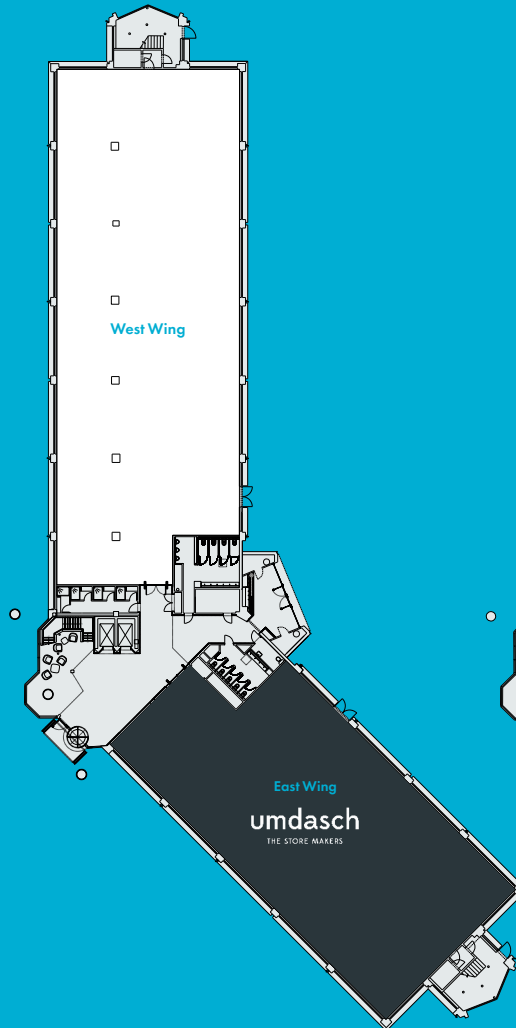

First

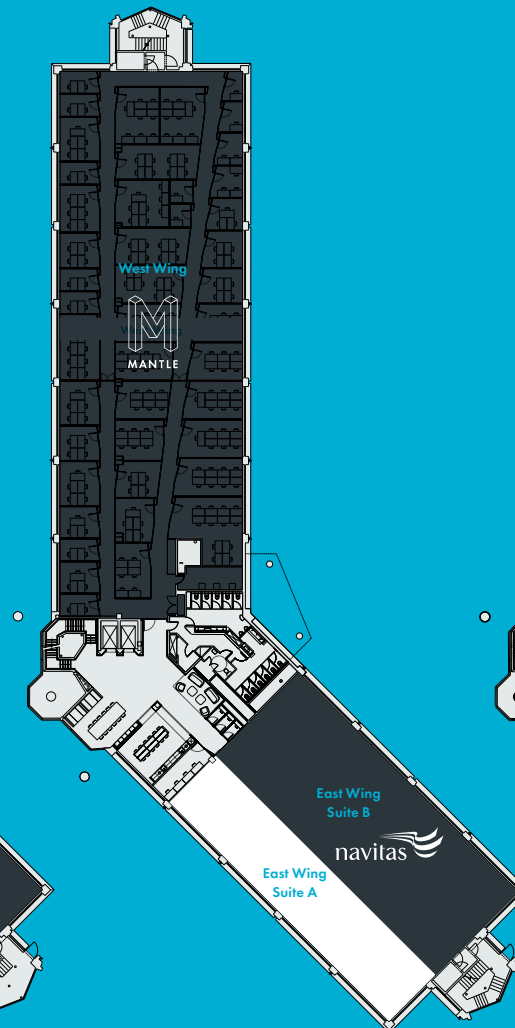

Second

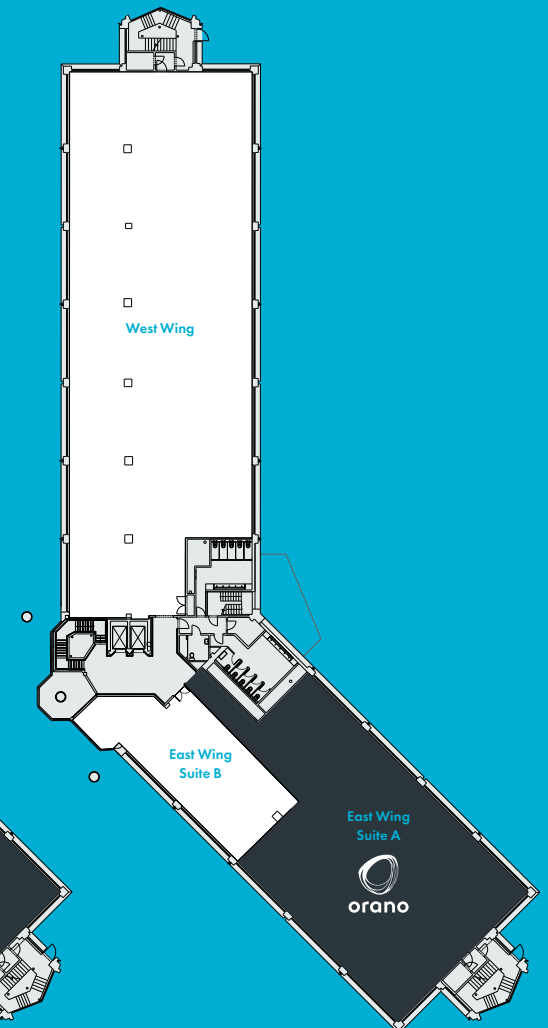

GROUND FLOOR

West Wing
830.8/8,943 (sqm/sqft)

East Wing
Let – Umdasch

Bespoke fitted solutions available to suit exact requirements, with a range of flexible payment structures.

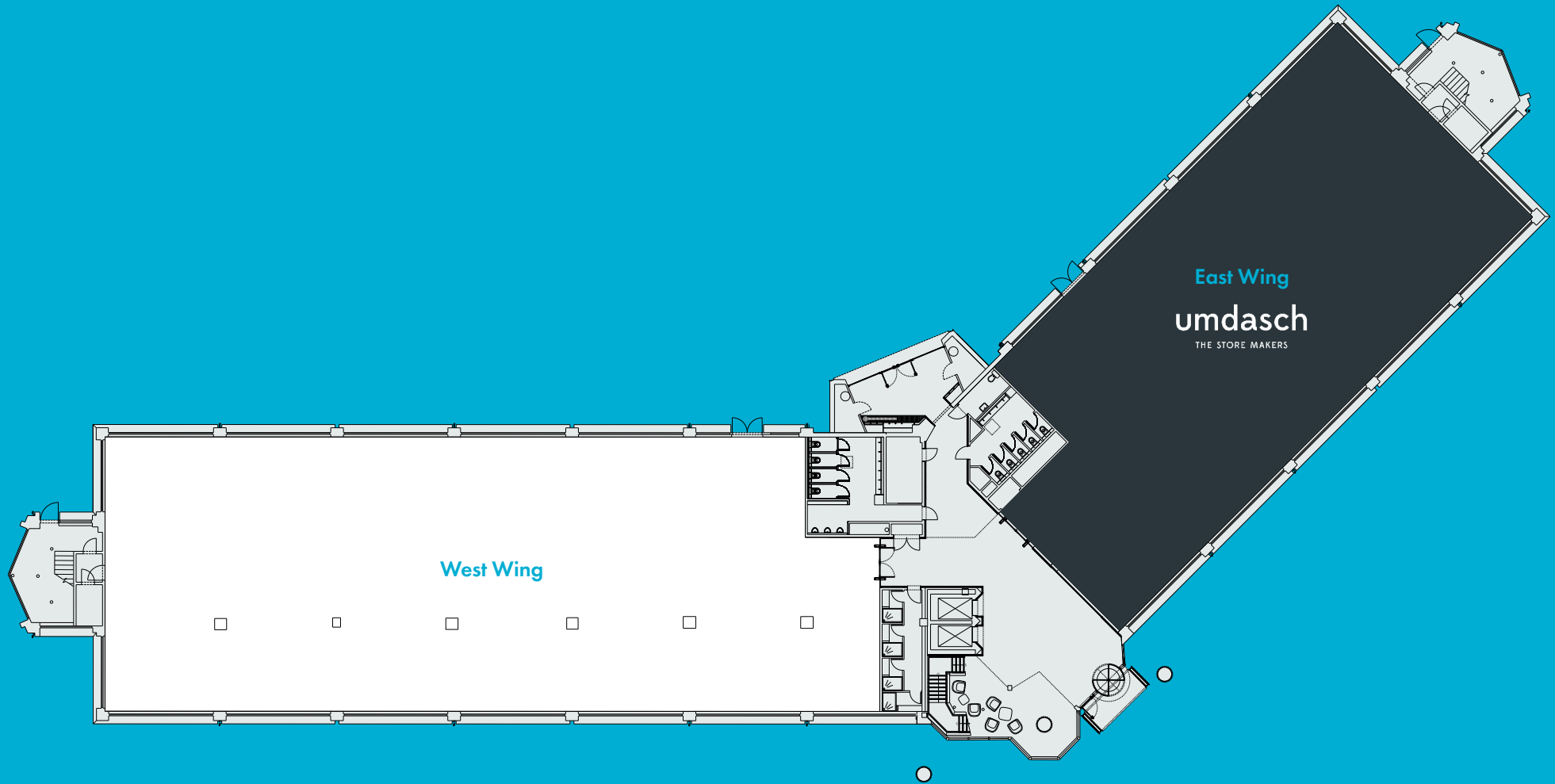

FIRST FLOOR

West Wing
Let – Mantle

East Wing – Suite A
177.2/1,907 (sqm/sqft)

East Wing – Suite B
Let – Navitas

Bespoke fitted solutions available to suit exact requirements, with a range of flexible payment structures.

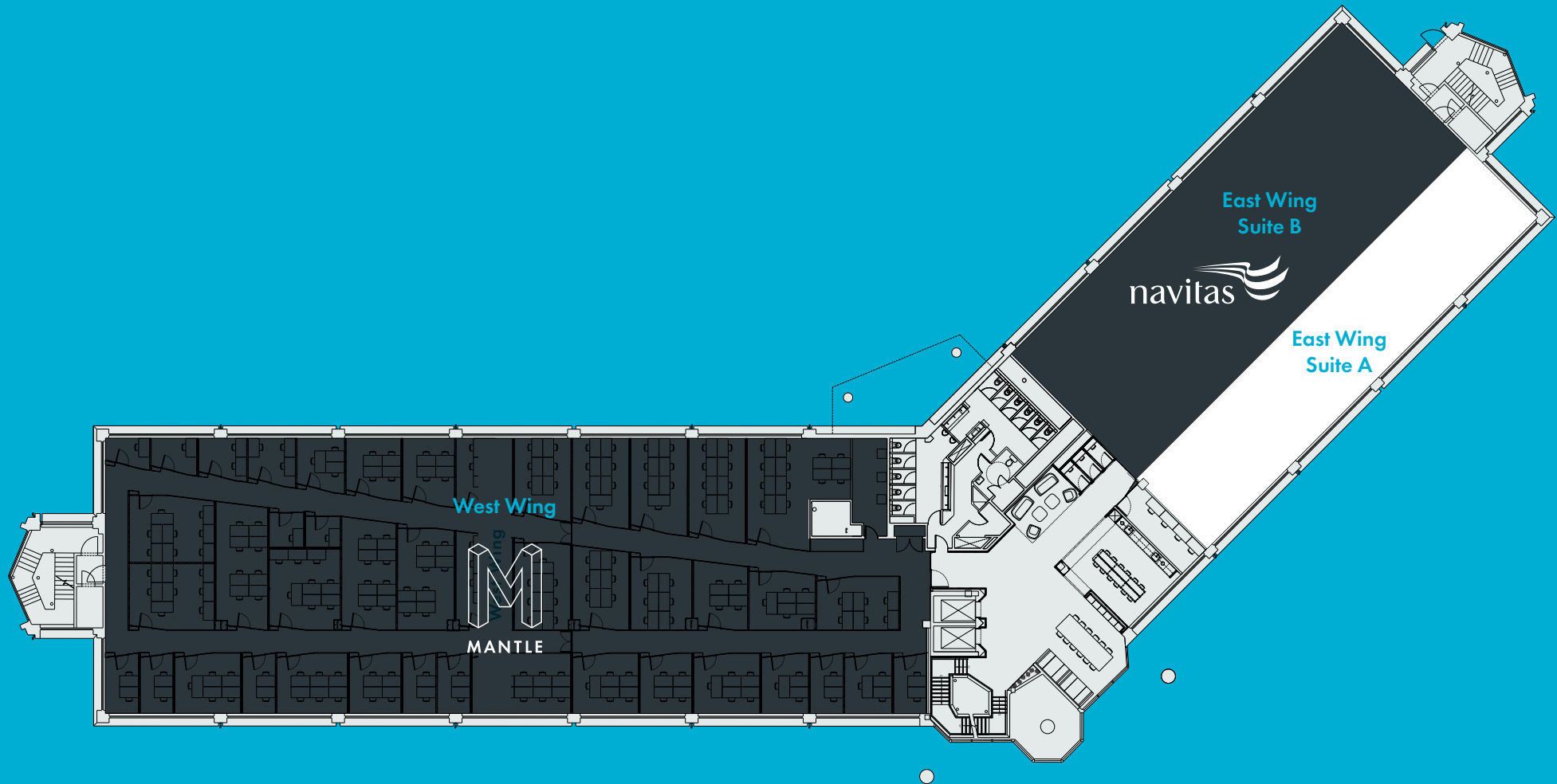

SECOND FLOOR

West Wing
867.9/9,342 (sqm/sqft)

East Wing – Suite A
Let – Orano

East Wing – Suite B
152/1,636 (sqm/sqft)

Bespoke fitted solutions available to suit exact requirements, with a range of flexible payment structures.

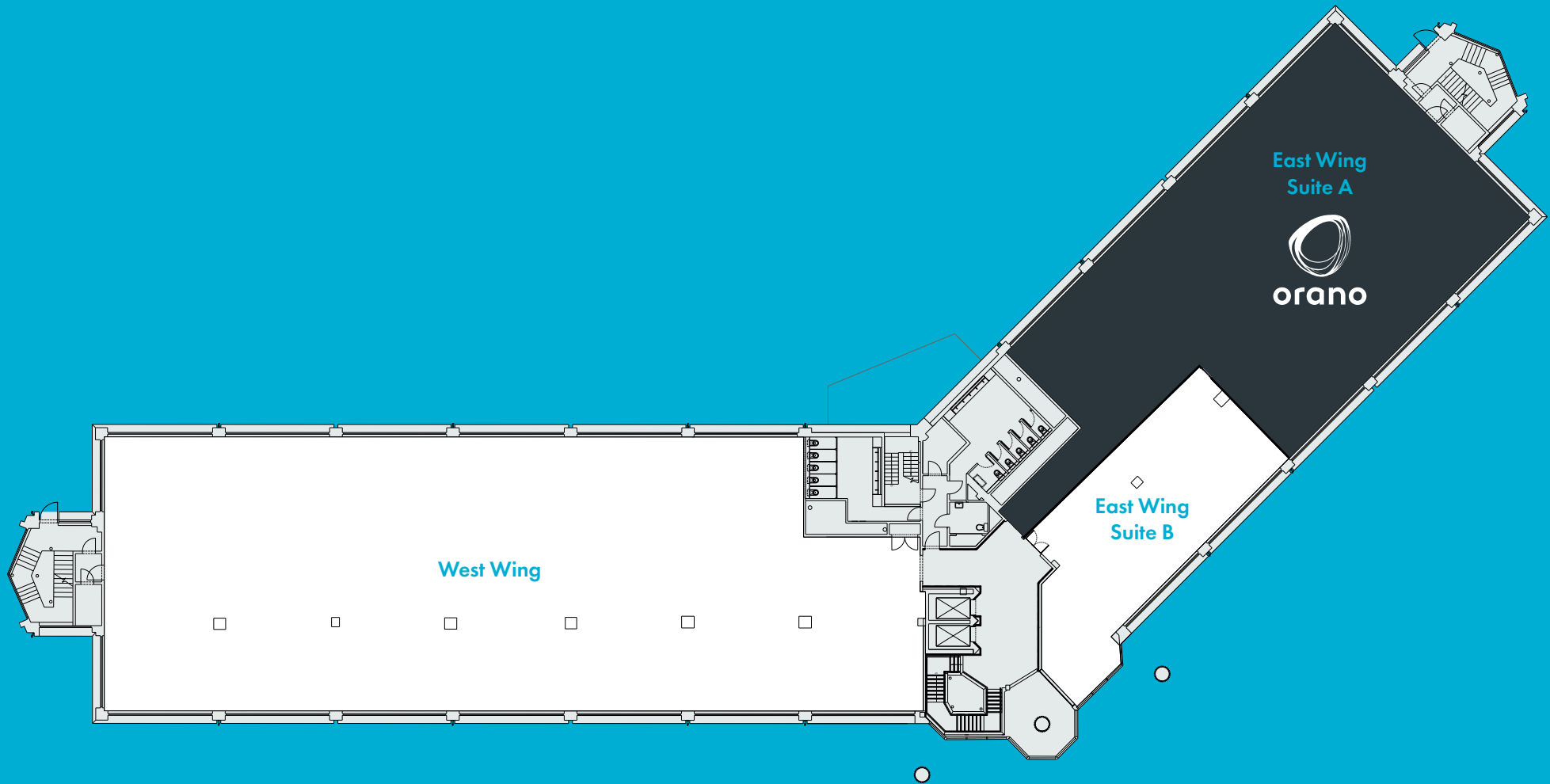

OCCUPIER CASE STUDY

Ideal conditions for Umdasch's international business

In Abingdon, the Store Makers have 50 percent more office space available than at their previous location in Oxford. Both customers and employees benefit from this. A prototype area in the centre of the office is the heart of the new location. This is where shopfitting life pulsates – prototypes and furniture of current customer projects are presented on this constantly changing stage. State-of-the-art lighting and stage technology is used for this. Curtains provide flexible room separation and, depending on the setting, offer exciting views in and out.

The excellent infrastructure around the Abingdon Business Park is another reason for the move. Abingdon is highly accessible to and from London, Central and Northern England and is in immediate proximity to several airports. So these are ideal conditions for the international business of umdasch which is managed from the British office.

In cooperation with top architects and established store designers the umdasch experts in the UK accompany premium brands like Harrods, Nike, Stone Island, KaDeWe, NIO, Bucherer and many others.

The entire office is equipped with state-of-the-art meeting and conference technology and also creates space for a retreat with communication booths. The Store Makers not only work with global players in sports retail, but also stay fit themselves. For example, the team has two meeting rooms with treadmills and indoor bicycles to keep them moving during longer meetings. For all sports enthusiasts who come to work on their bikes & Co, showers have also been provided. Height-adjustable desks support healthy and ergonomic working.







THE
LAMBOURN
AIRMUSEUM

Opening hours: 10am - 4pm
Closed: 24th Dec - 1st Jan
For all our facilities
AVAILABLE NOW

GET IN TOUCH

BENEDICTS
CONSULTANT SURVEYORS

For all letting enquiries and viewings

Edward Lively MRICS
Director
07464 492953
edward@benedicts.co.uk

Carter Jonas

Adrian Chan
Associate
07920 830554
Adrian.Chan@carterjonas.co.uk



Owned and managed by

Mantle
01279 874302
mantle.co.uk

IMPORTANT NOTICE

These particulars are for general information purposes only and do not represent an offer of contract or part of one. Benedicts and Carter Jonas has made every attempt to ensure that the particulars and other information provided are as accurate as possible and are not intended to amount to advice on which you should rely as being factually accurate. You should not assumed that the property has all necessary planning, building regulations or other consents and Benedicts or Carter Jonas have not tested any services, facilities or equipment. Any measurements and distances given are approximate only. Purchasers must satisfy themselves of all of the aforementioned by independent inspection or otherwise. Although we make reasonable efforts to update our information, neither Benedicts or Carter Jonas LLP nor anyone in their employment or acting on its behalf makes any representations warranties or guarantees, whether express or implied, in relation to the property, or that the content in these particulars is accurate, complete or up to date. Our images only represent part of the property as it appeared at the time they were taken. If you require further information please contact us.

What 3 Words /// [Deploying.electrode.cities](https://www.what3words.com/)
The Lambourn Wyndyke Furlong, Abingdon OX14 1UJ

[thelambournabingdon.co.uk](https://www.thelambournabingdon.co.uk)