

FOR LEASE

Mayhew Office Park

140 Mayhew Way, Pleasant Hill, CA



COMMERCIAL REAL ESTATE SERVICES



PROPERTY HIGHLIGHTS

- Two Story Garden Style Suburban Office Park
- Short Term Leases Available
- One Block to Interstate 680
- Close to Retail Services
- Contra Costa County Bus Service to the Curb
- Abundant Parking 4/1,000 SF
- Comcast Business Class Internet Service Available
- Rent: \$2.10 psf

Available Space

Suite 200	±1,575 SF
Suite 401	±1,200 SF
Suite 503	±486 SF
Suite 701*	±650 SF
Suite 702*	±875 SF
Suite 1000	±400 SF
Suite 1003	±400 SF

*can be combined with suite 702
for a total of 1,525 sf

For more information, please contact:

Dan Moylan
Principal
925.239.1427
dmoylan@lee-associates.com
LIC #00845782

FOR LEASE

Mayhew Office Park

140 Mayhew Way, Pleasant Hill, CA

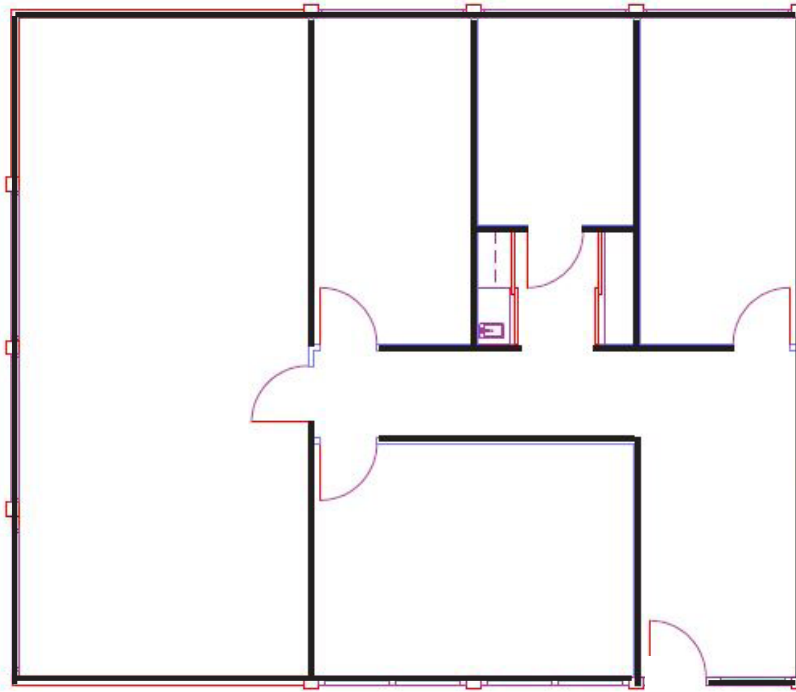

Suite 200
±1,575 SF

For more information, please contact:

Dan Moylan
Principal
925.239.1427
dmoylan@lee-associates.com
LIC #00845782

FOR LEASE

Mayhew Office Park

140 Mayhew Way, Pleasant Hill, CA

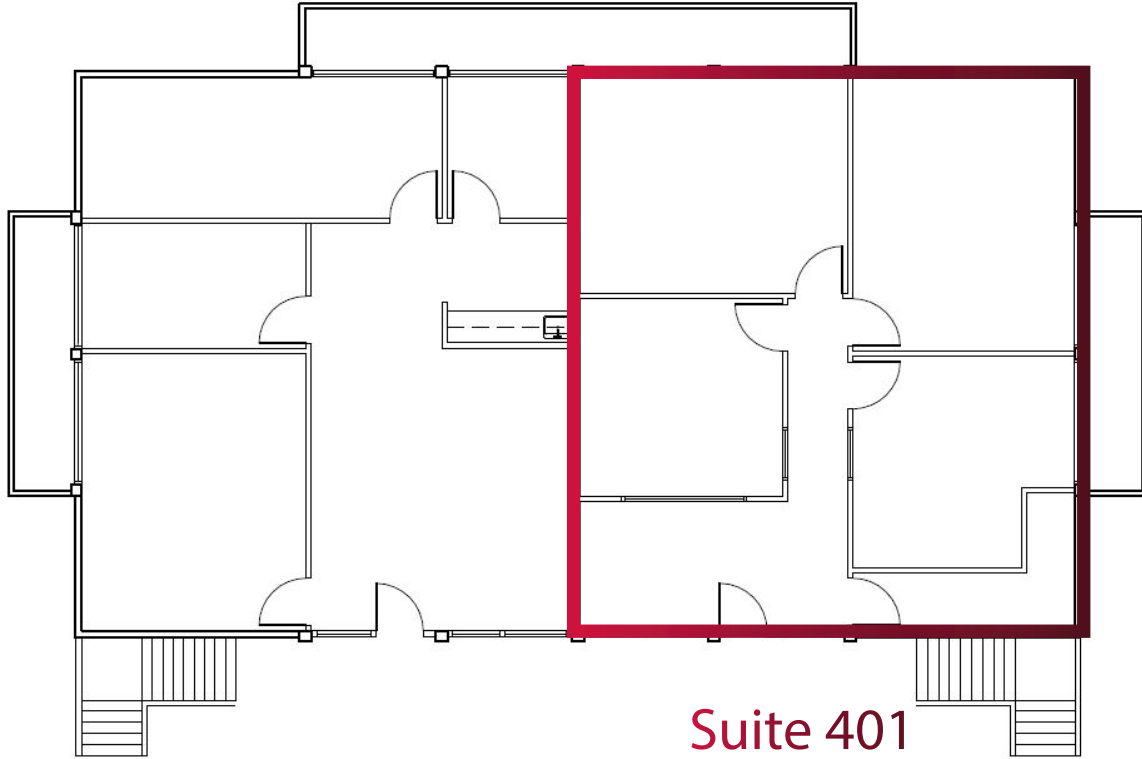

Suite 401
±1,200 SF

For more information, please contact:

Dan Moylan
Principal
925.239.1427
dmoylan@lee-associates.com
LIC #00845782

FOR LEASE

Mayhew Office Park

140 Mayhew Way, Pleasant Hill, CA

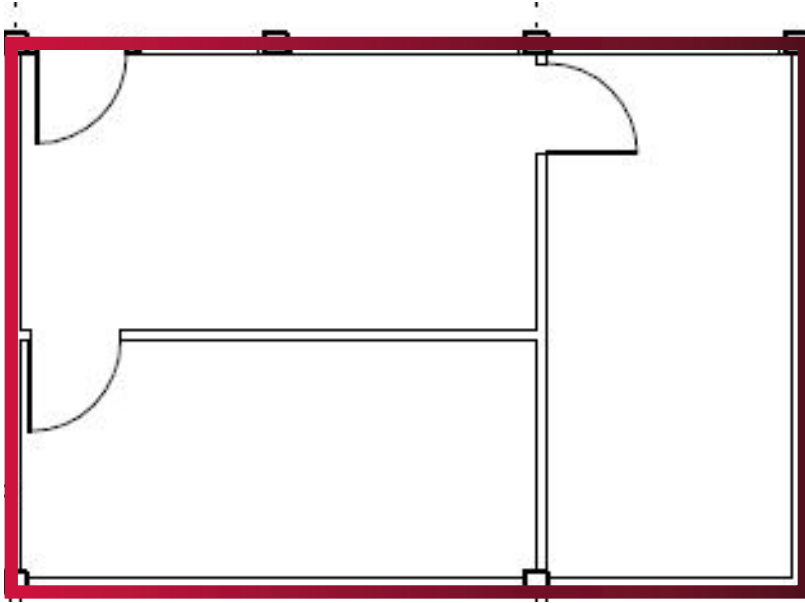

Suite 503
±486 SF

For more information, please contact:

Dan Moylan
Principal
925.239.1427
dmoylan@lee-associates.com
LIC #00845782

FOR LEASE

Mayhew Office Park

140 Mayhew Way, Pleasant Hill, CA

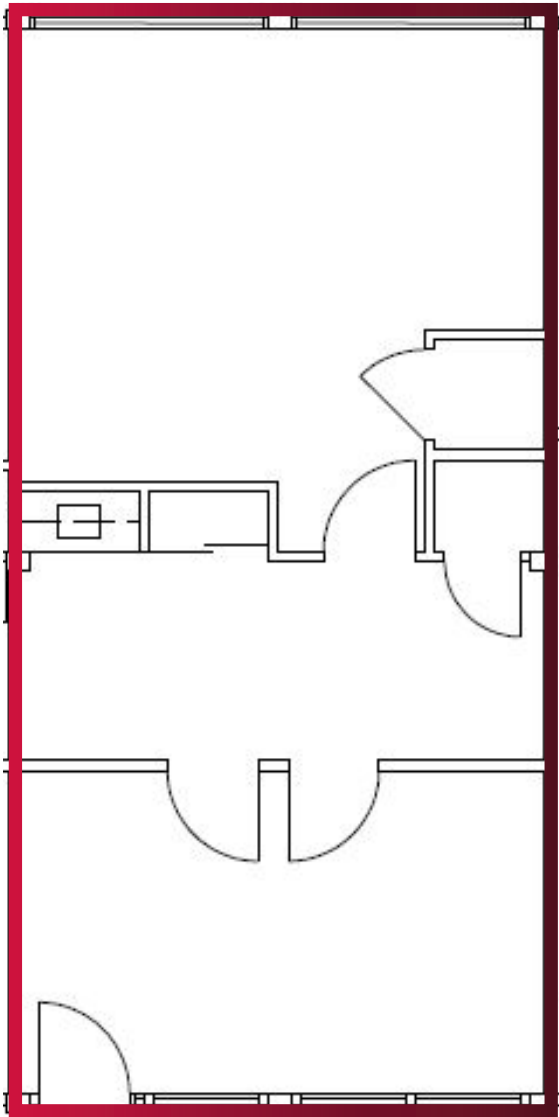

Suite 701
±650 SF

For more information, please contact:

Dan Moylan
Principal
925.239.1427
dmoylan@lee-associates.com
LIC #00845782

FOR LEASE

Mayhew Office Park

140 Mayhew Way, Pleasant Hill, CA

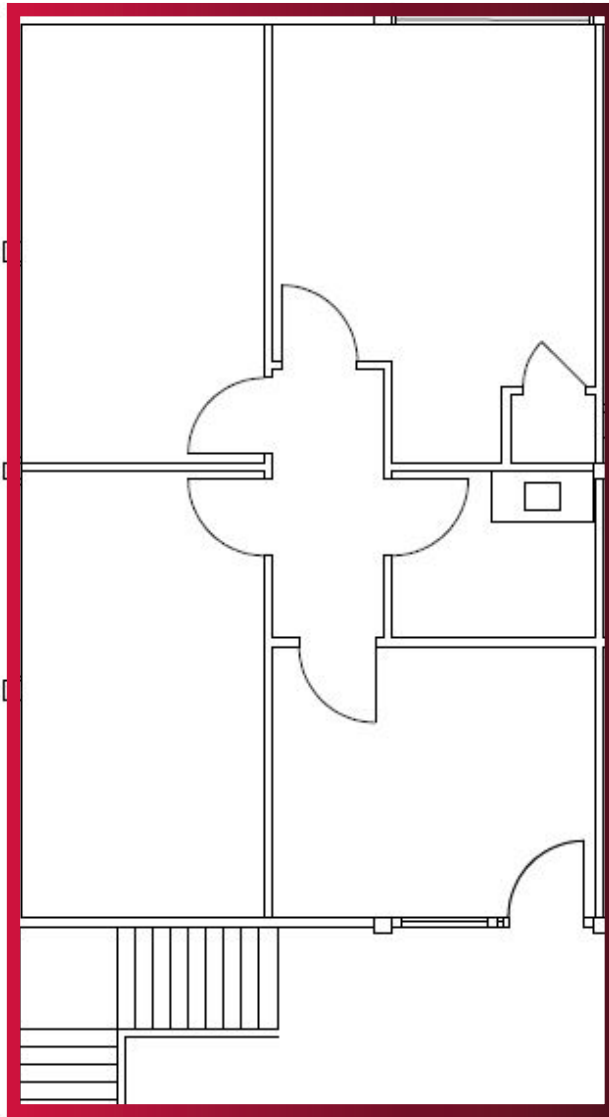

Suite 702

±875 SF

- Three (3) Offices
- Breakroom
- Reception

For more information, please contact:

Dan Moylan
Principal
925.239.1427
dmoylan@lee-associates.com
LIC #00845782

FOR LEASE

Mayhew Office Park

140 Mayhew Way, Pleasant Hill, CA

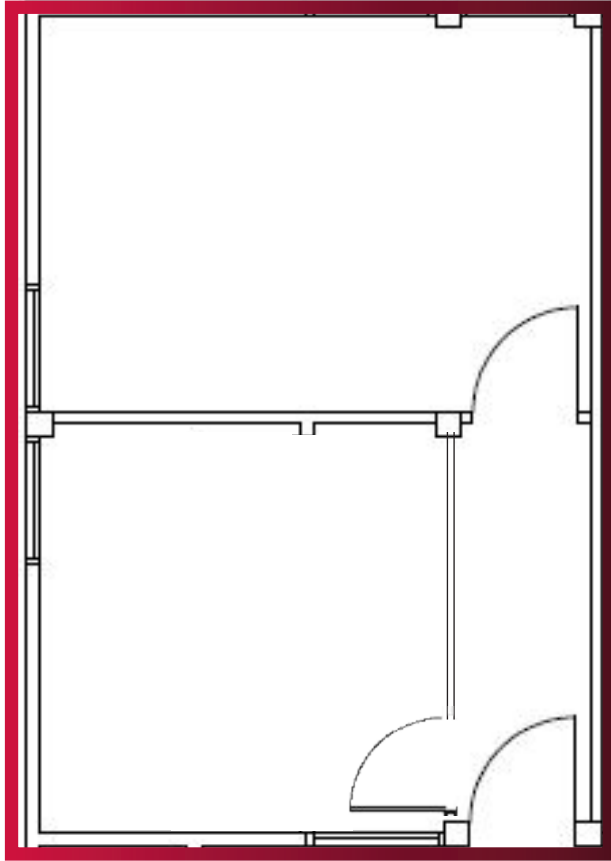

Suite 1000

±400 SF

- Two (2) Private Offices
- Reception

For more information, please contact:

Dan Moylan
Principal
925.239.1427
dmoylan@lee-associates.com
LIC #00845782

FOR LEASE

Mayhew Office Park

140 Mayhew Way, Pleasant Hill, CA

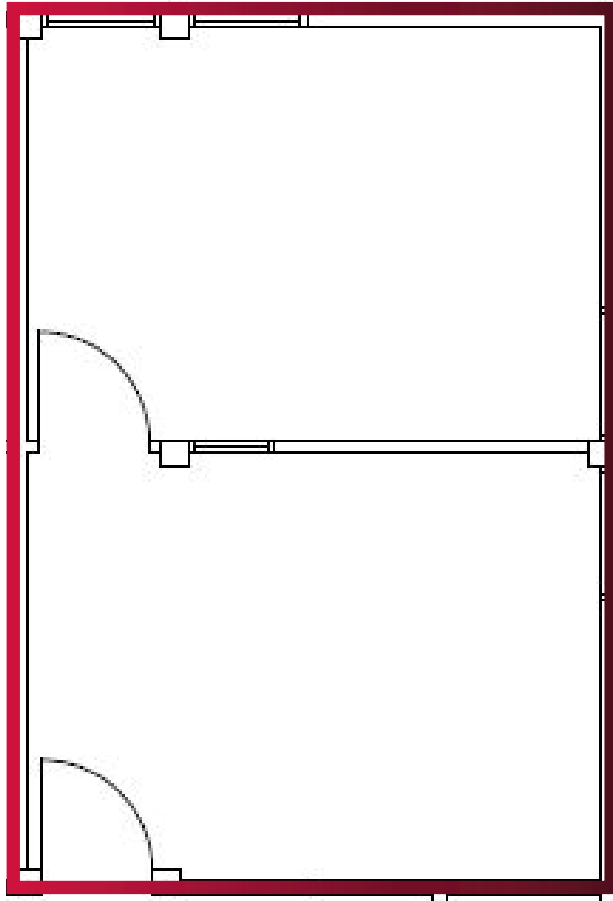

Suite 1003
±400 SF

For more information, please contact:

Dan Moylan
Principal
925.239.1427
dmoylan@lee-associates.com
LIC #00845782