

Office



---

# CitiCentre Building

**OFFICES FROM 1,200 SF TO 6,720 SF  
FOR LEASE**

290 NW 165th St | Miami, FL 33169

**For More Information**

**Sherry Halstead**

+1 305 775 6953

shalstead@naimiami.com

For more listings visit: [naimia-ftl.com/properties](http://naimia-ftl.com/properties)

**NAI** Miami  
Fort Lauderdale

# CitiCentre Building

290 NW 165th St | Miami, FL 33169

## Property Features

- Quality turnkey buildouts
- Plenty of natural light - window lined offices
- Efficient layouts
- Move-in ready
- Each suite is separately metered

## Availability

<b>**P600/P700</b>	2,491 RSF	\$32.00 PSF*
<b>P-600</b>	1,200 RSF	\$32.00 PSF*
<b>P-700</b>	1,291 RSF	\$32.00 PSF*

<b>**PH 5</b>	6,720 RSF	\$32.00 PSF*
<b>PH 5A</b>	2,384 RSF	\$32.00 PSF*
<b>PH 5B</b>	2,003 RSF	\$32.00 PSF*
<b>PH 5C</b>	2,333 RSF	\$32.00 PSF*

\* Base rent is on a modified gross basis, electricity is separately metered

\*\* Suites can be combined or leased separately

## Recent Upgrades

- Lobby has been painted and refreshed
- Hallways repainted, new ceiling tiles and light fixtures
- Elevator areas and interior cabs have been upgraded
- Covered parking area is painted and pressure washed
- Parking area is newly sealcoated





# CitiCentre Building

290 NW 165th St | Miami, FL 33169

## Location Features

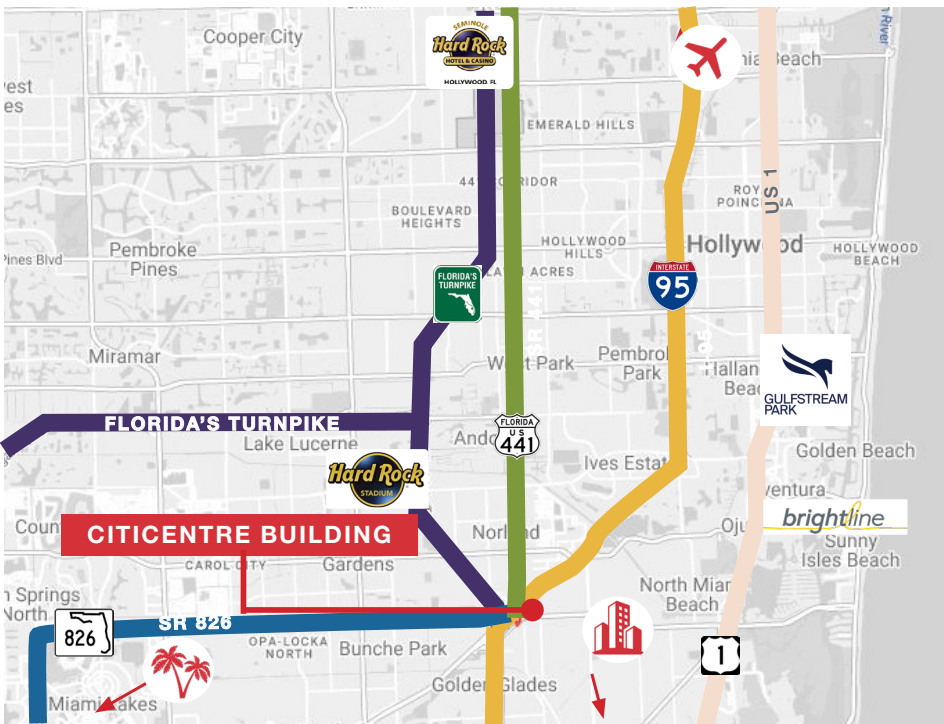
- Responsible long term ownership/ management
- Recently upgraded hallways, lobby, and elevator cabs
- On-site security and property manager
- Includes upgraded exterior lighting and building monitoring
- Strategically located with easy access to I-95, Florida's Turnpike, SR 826, and SR 441
- Minutes from Tri-Rail Park and Ride lots



  
**MIAMI INTERNATIONAL AIRPORT**  
± 13.4 Miles  
21 Minutes

  
**DOWNTOWN MIAMI**  
± 11.4 Miles  
18 Minutes

  
**FORT LAUDERDALE-HOLLYWOOD INTERNATIONAL AIRPORT**  
± 15.2 Miles  
18 Minutes

# Floor Plan - P-600 & P-700

290 NW 165th St | Miami, FL 33169

P-600 & P-700 - 2,491 RSF

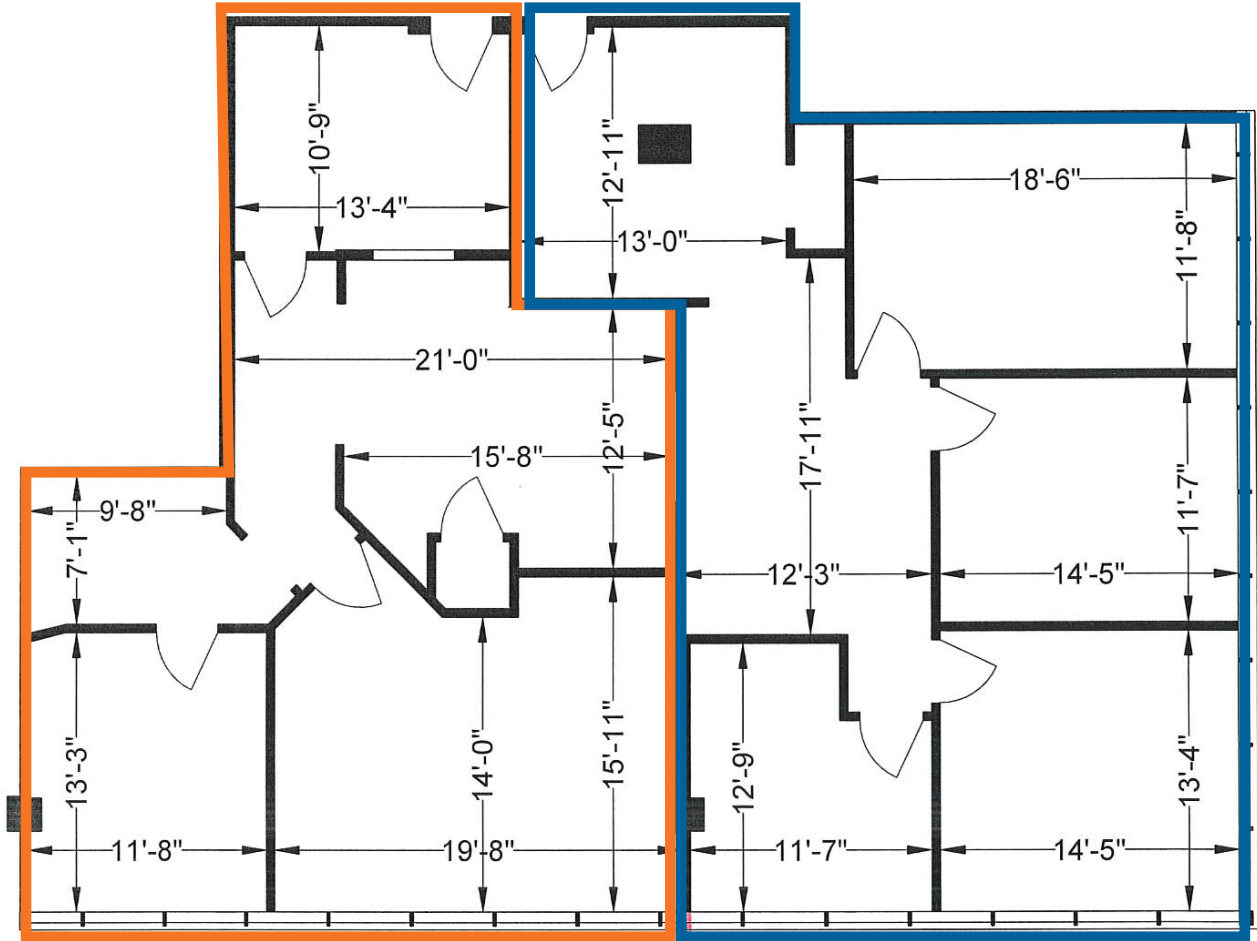

P- 600 - 1,200 RSF

P- 700 - 1,291 RSF

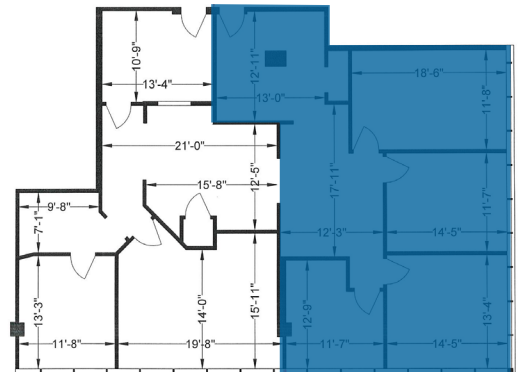
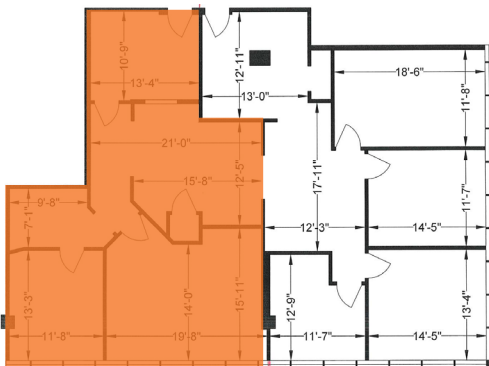

# Floor Plan - PH 5A

290 NW 165th St | Miami, FL 33169

2,384 RSF

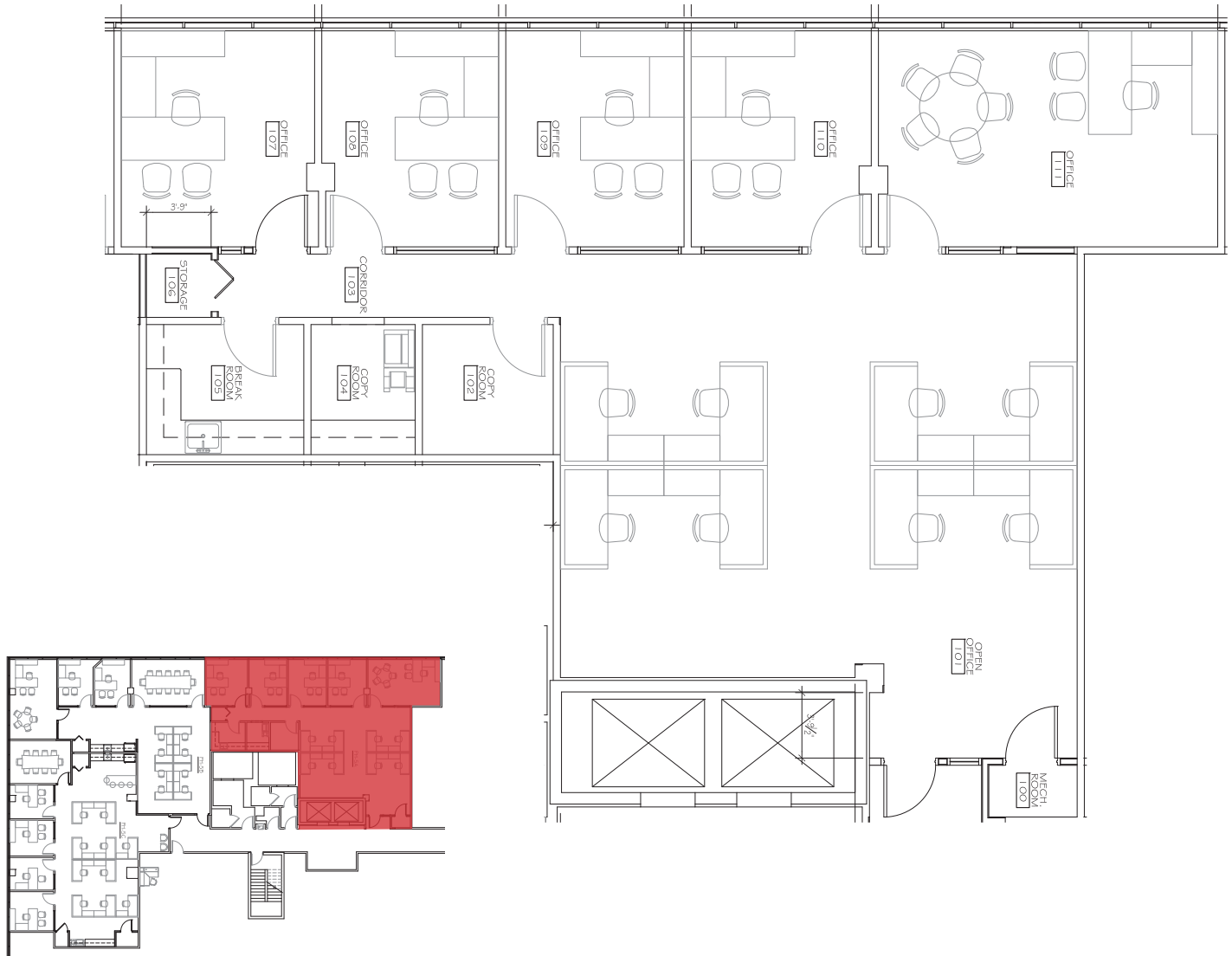

- Four (4) offices on window line
- Two (2) small interior admin offices
- Conference room on window line
- Bullpen area for eight (8) people
- Breakrooms
- IT closet/storage

# Floor Plan - PH 5B

290 NW 165th St | Miami, FL 33169

2,003 RSF

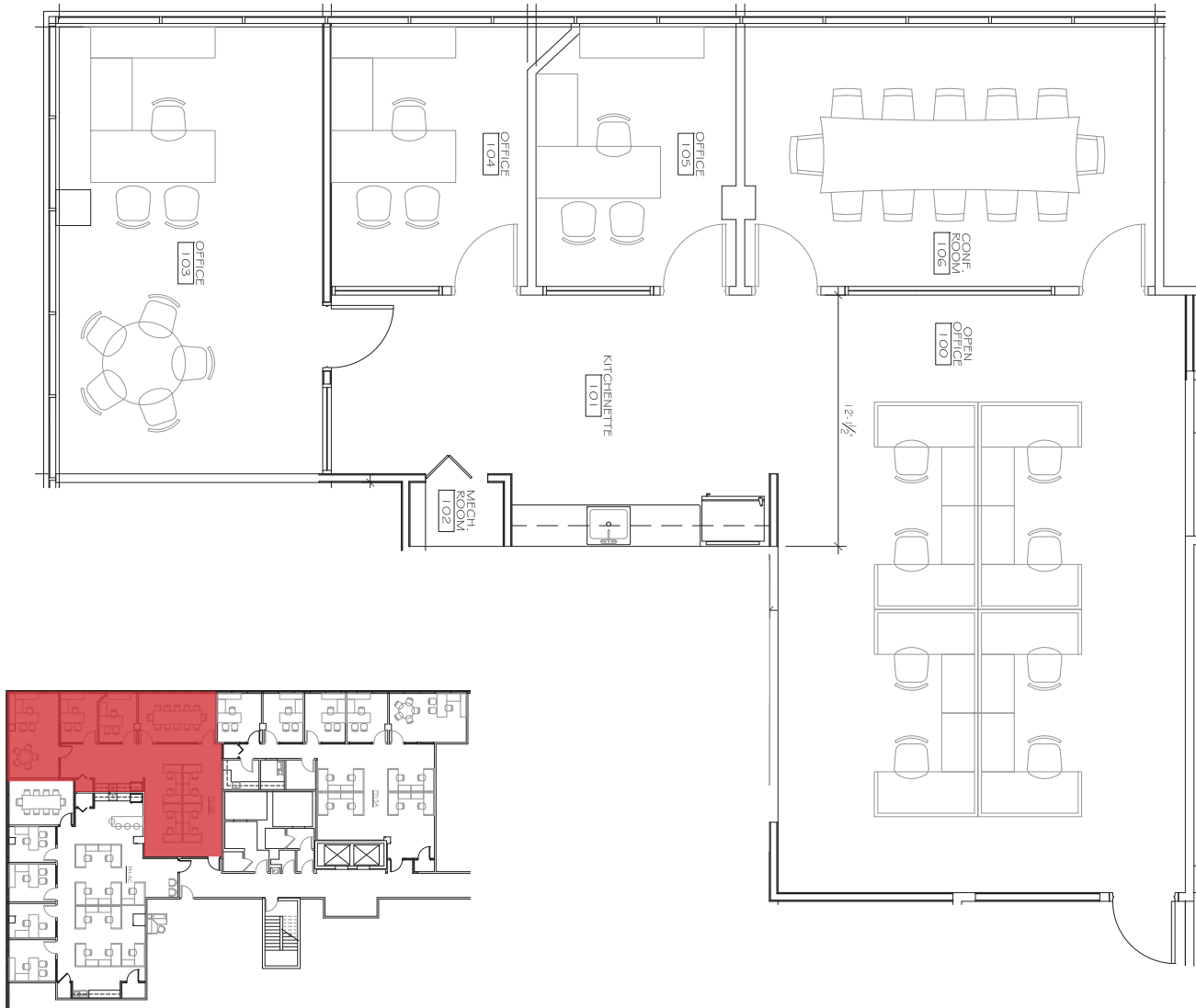

- Two (2) small & One (1) large offices on window line
- One (1) large conference room on corner of window line
- Bullpen area for eight (8) people
- Open kitchenette area

# Floor Plan - PH 5C

290 NW 165th St | Miami, FL 33169

2,333 RSF



- Small reception area
- Four (4) offices on window line
- Conference room
- Open area to seat 10 people
- Open kitchenette
- Storage closet
- IT closet

---

# Floor Plan - PH 5

290 NW 165th St | Miami, FL 33169

PH 5A, PH 5B, & PH 5C

Up to 6,720 RSF

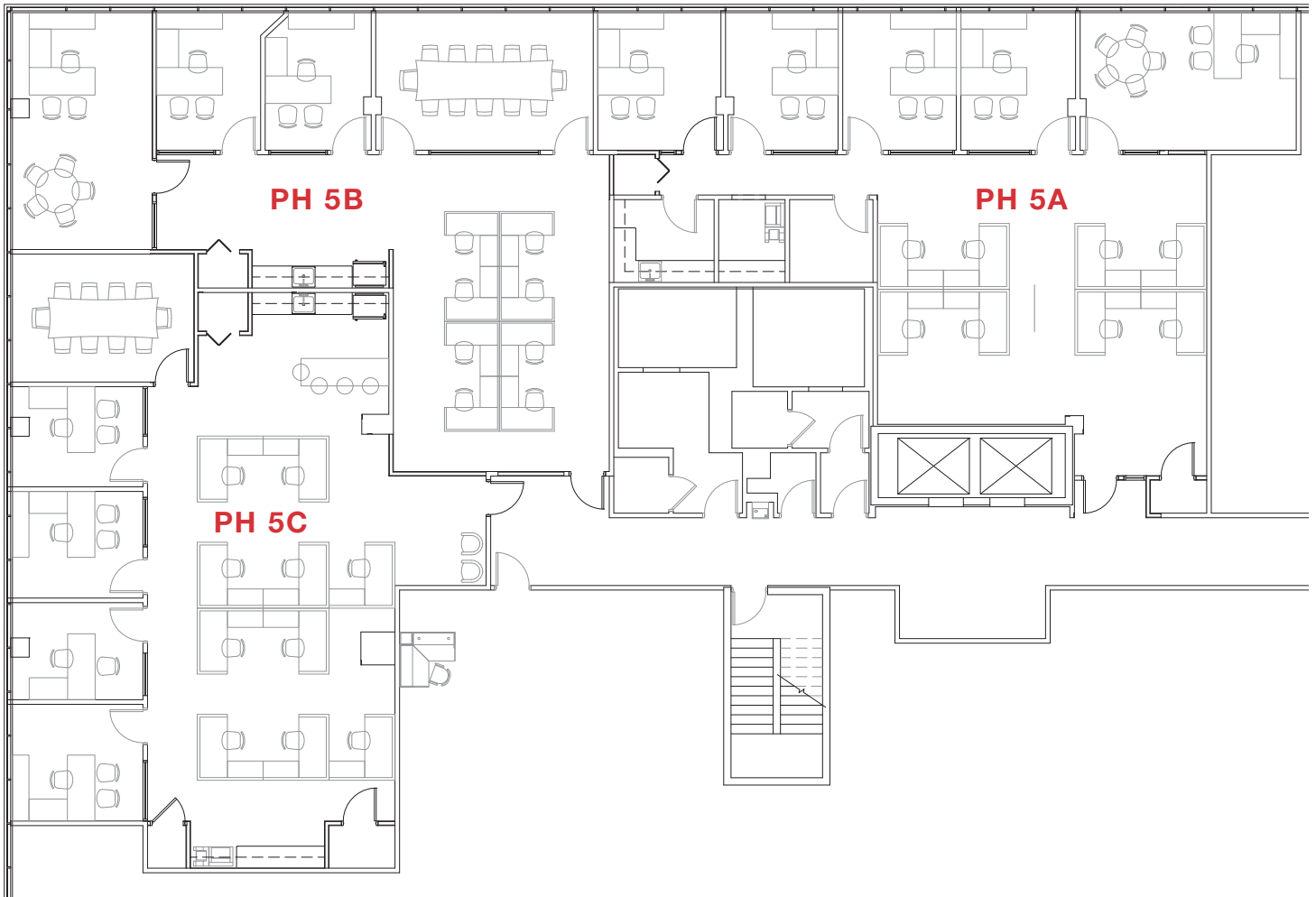

---

## For More Information

Sherry Halstead

+1 305 775 6953

shalstead@naimiami.com



📍 9655 South Dixie Highway, Suite 300, Miami, FL 33156

📞 +1 305 938 4000

🌐 naimia-ftl.com

NO WARRANTY OR REPRESENTATION, EXPRESS OR IMPLIED, IS MADE AS TO THE ACCURACY OF THE INFORMATION CONTAINED HEREIN, AND THE SAME IS SUBMITTED SUBJECT TO ERRORS, OMISSIONS, CHANGE OF PRICE, RENTAL OR OTHER CONDITIONS, PRIOR SALE, LEASE OR FINANCING, OR WITHDRAWAL WITHOUT NOTICE, AND OF ANY SPECIAL LISTING CONDITIONS IMPOSED BY OUR PRINCIPALS NO WARRANTIES OR REPRESENTATIONS ARE MADE AS TO THE CONDITION OF THE PROPERTY OR ANY HAZARDS CONTAINED THEREIN ARE ANY TO BE IMPLIED.