

**LEASE**

# San Ysidro Center

**8610-8660 SAN YSIDRO AVE**

Gilroy, CA 95020

**PRESENTED BY:**

**MIKE PRIOLO**

O: 408.439.8875

mike.priolo@svn.com

CalDRE #01878385

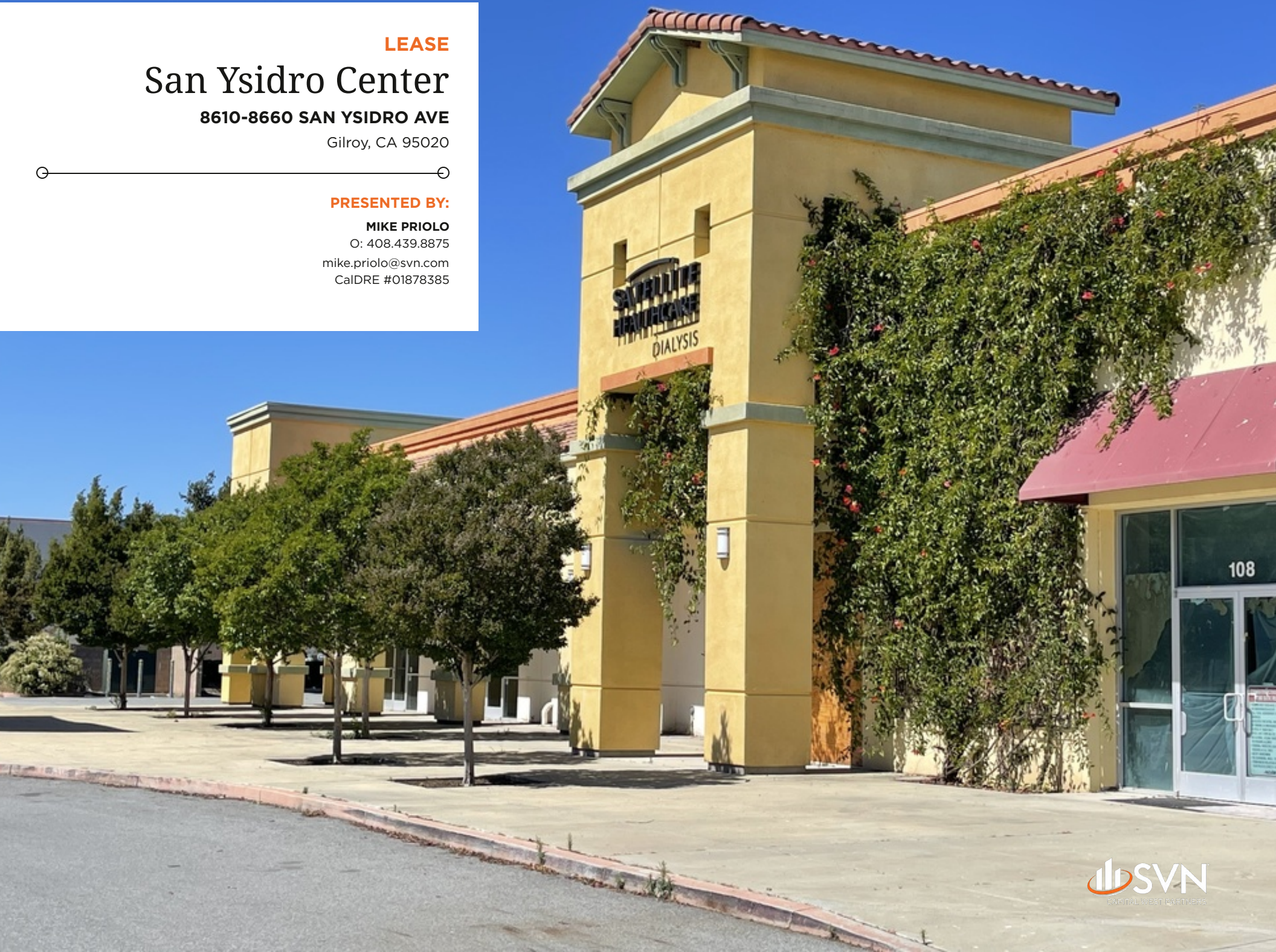

# PROPERTY SUMMARY

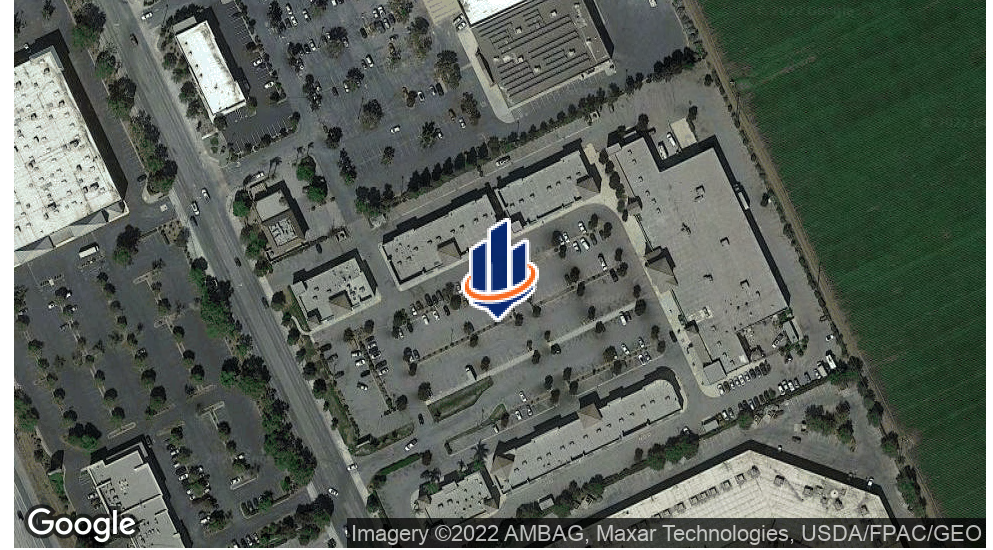

## OFFERING SUMMARY

<b>LEASE RATE:</b>	\$1.80 - 2.00 SF/month (NNN)
<b>BUILDING SIZE:</b>	100,000 SF
<b>AVAILABLE SF:</b>	1,005 - 26,925 SF
<b>LOT SIZE:</b>	9.48 Acres
<b>YEAR BUILT:</b>	2008
<b>ZONING:</b>	C3
<b>MARKET:</b>	South County

### MIKE PRIOLO

O: 408.439.8875  
mike.priolo@svn.com  
CalDRE #01878385

## PROPERTY HIGHLIGHTS

- Wide Variety of Suite Sizes and Configurations Available - suites range from +-1,200 to +-27,000 SF
- Zoned C3 Shopping Center Commercial Which Allows for a Wide Variety of Commercial, Office and Industrial Uses!
- Suite 104 has two loading docs and can be demised
- Motivated Landlord TI Allowance and Rent Abatement Available for Qualified Tenants!
- Low NNN expenses - Estimated at \$0.40/SF ( For Year 2022)
- Ample Parking
- Co-Anchored by Satellite Dialysis and Garlic City Casino

## PROPERTY DETAILS & HIGHLIGHTS

<b>BUILDING NAME</b>	San Ysidro Center
<b>PROPERTY TYPE</b>	Retail
<b>PROPERTY SUBTYPE</b>	Outlet Center
<b>BUILDING SIZE</b>	100,000 SF
<b>LOT SIZE</b>	9.48 Acres
<b>YEAR BUILT</b>	2008
<b>NUMBER OF FLOORS</b>	1

San Ysidro Center offers tenants a wide variety of space options within the center. With suite sizes ranging from +/-1,200 to +/-27,000 any tenant can find a suite to fit their needs at San Ysidro Center. In addition, the site is in very close proximity to Highway 101 which boasts 90,000+ traffic counts, and national retailers such as Home Depot, Walmart, Costco, Lowes, Best Buy. When coupled with Gilroy's excellent demographics, San Ysidro Center offers tremendous potential for local, regional and national tenants.

### MIKE PRIOLO

O: 408.439.8875

mike.priolo@svn.com

CalDRE #01878385



# RETAILER AERIAL



**MIKE PRIOLO**

O: 408.439.8875

mike.priolo@svn.com

CalDRE #01878385

**PROPERTY AERIAL**



**MIKE PRIOLO**

O: 408.439.8875  
mike.priolo@svn.com  
CalDRE #01878385

# RETAILER MAP

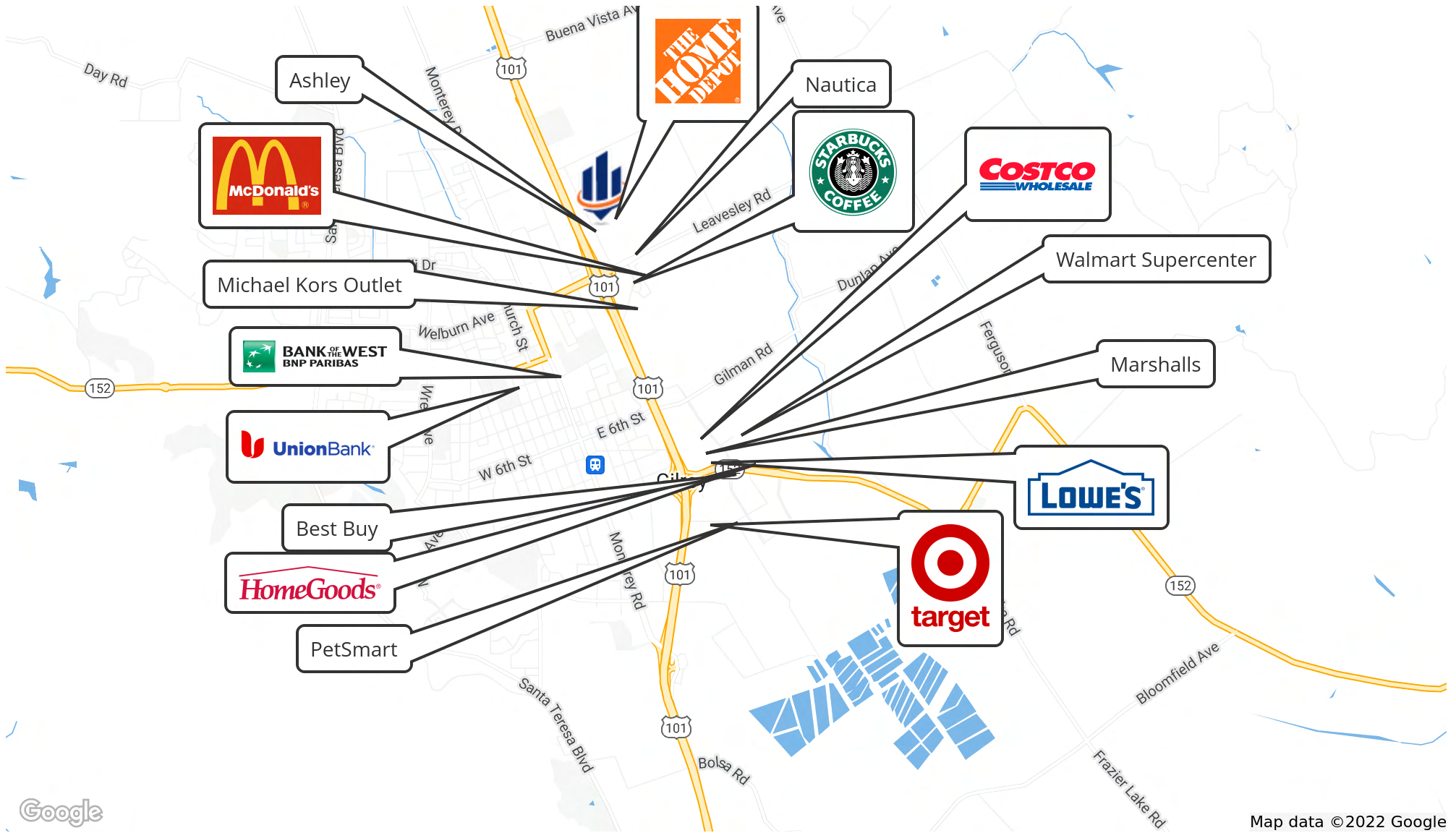

**MIKE PRIOLO**

O: 408.439.8875

mike.priolo@svn.com

CalDRE #01878385

# SAN YSIDRO CENTER

8610-8660



ROLL



GARLIC CITY  
**CASINO**

BAY CITY  
**FURNITURE**

A<sup>TELLITE</sup> HEALTHCARE

**DYLAN HAIR & NAILS**

**GAME WORLD #2**

CROSSFIT MOR<sup>Λ</sup>

**LOVER'S OUTLET**



**TK NOODLE**

**L&C PURE WATER**

**TAPIOCA EXPRESS**

**GILROY OPTOMETRY**

**NHC NUTRITION**

**H&T DENTAL CARE**

**SPLENDID SPA**

**GAME WORLD #2**

**SPLENDID FOOT**

**THE GARLIC SHOPPE**

**SITE PLAN**

*Site Plan & Availabilities*



- Suite 104 - Gilroy Business Center
  - Suite 108 - TK Noodle
- BUILDING 8650**
- Suite 100 - L & C Pure Water
  - Suite 102 - Star Tea
  - Suite 104 - Gilroy Optometry
  - Suite 108 - AVAILABLE 1,360 SF
  - Suite 112 - H&T Dental Care
  - Suite 116 - AVAILABLE 1,337 SF
  - Suite 120 - AVAILABLE 1,388 SF
  - Suite 124 - Splendid Foot
  - Suite 128 - AVAILABLE 1,309 SF
- BUILDING 8640**
- Suite 100 - AVAILABLE 2,782 SF
  - Suite 108 - Dylan Hair & Nails
  - Suite 112 - AVAILABLE 1,383 SF
  - Suite 116 - AVAILABLE 1,337 SF
  - Suite 120 - AVAILABLE 2,476 SF
- BUILDING 8630**
- Suite 112 - AVAILABLE 2,363 SF
  - Suite 108 - Satellite Dialysis
  - Suite 120 - AVAILABLE 1,326 SF
  - Suite 104 - AVAILABLE 26,295 SF
  - Suite 100 - Casino
- BUILDING 8620**
- Suite 148 - AVAILABLE 2,247 SF
  - Suite 140 - AVAILABLE 2,245 SF
  - Suite 136 - AVAILABLE 1,146 SF
  - Suite 132 - AVAILABLE 1,106 SF
  - Suite 128 - AVAILABLE 1,657 SF
  - Suite 124 - AVAILABLE 1,155 SF
  - Suite 120 - AVAILABLE 1,094 SF
  - Suite 116 - Salad Master
  - Suite 112 - Green Rush  
Smoke Shop
  - Suite 108 - Splendid Spa
  - Suite 100 - AVAILABLE 3,009 SF

**MIKE PRIOLO**

O: 408.439.8875

mike.priolo@svn.com

CalDRE #01878385

FLOOR PLANS - 8620 STE 100

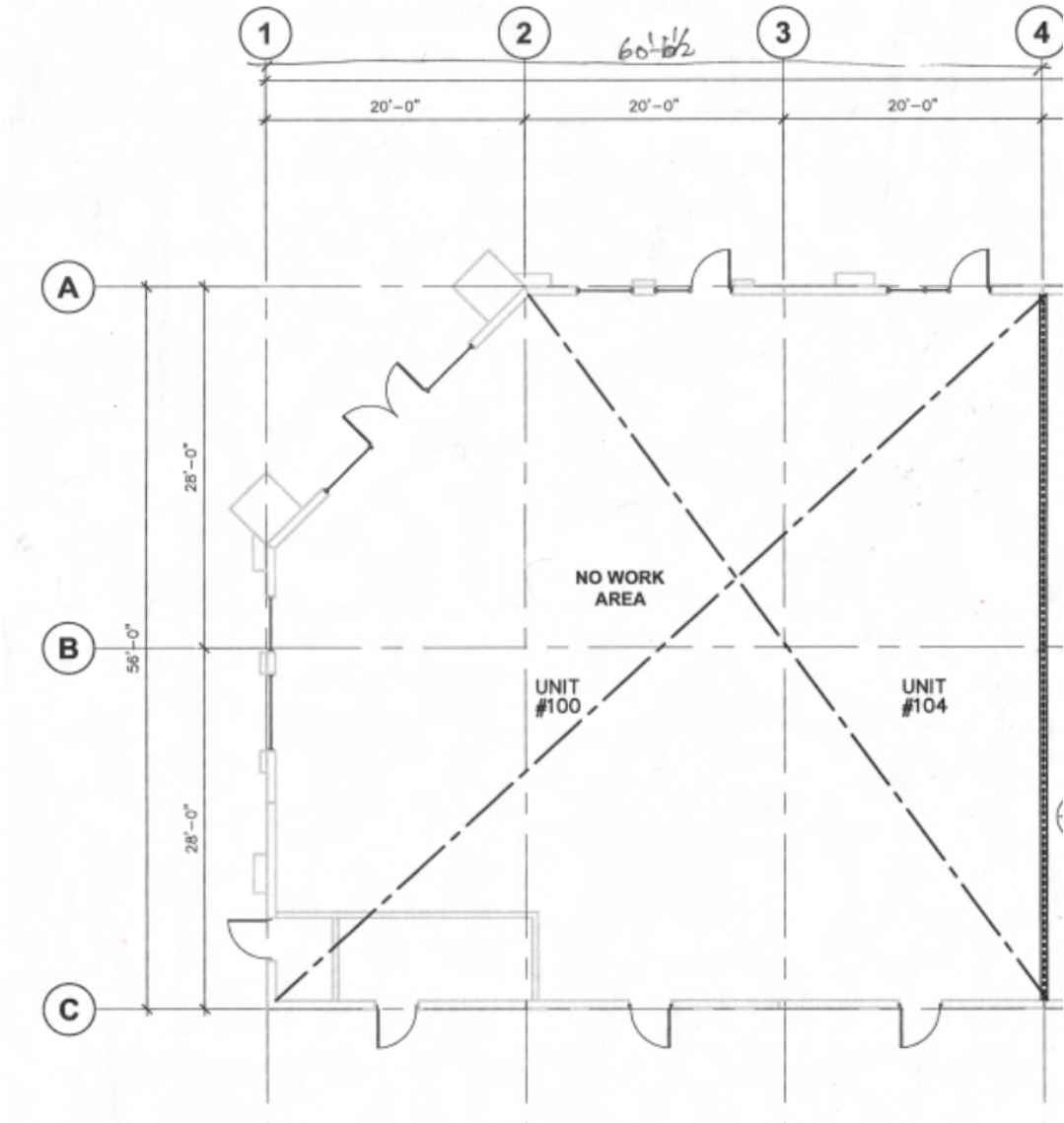

**MIKE PRIOLO**  
O: 408.439.8875  
mike.priolo@svn.com  
CalDRE #01878385

**FLOOR PLANS 8620 STE 116-148**

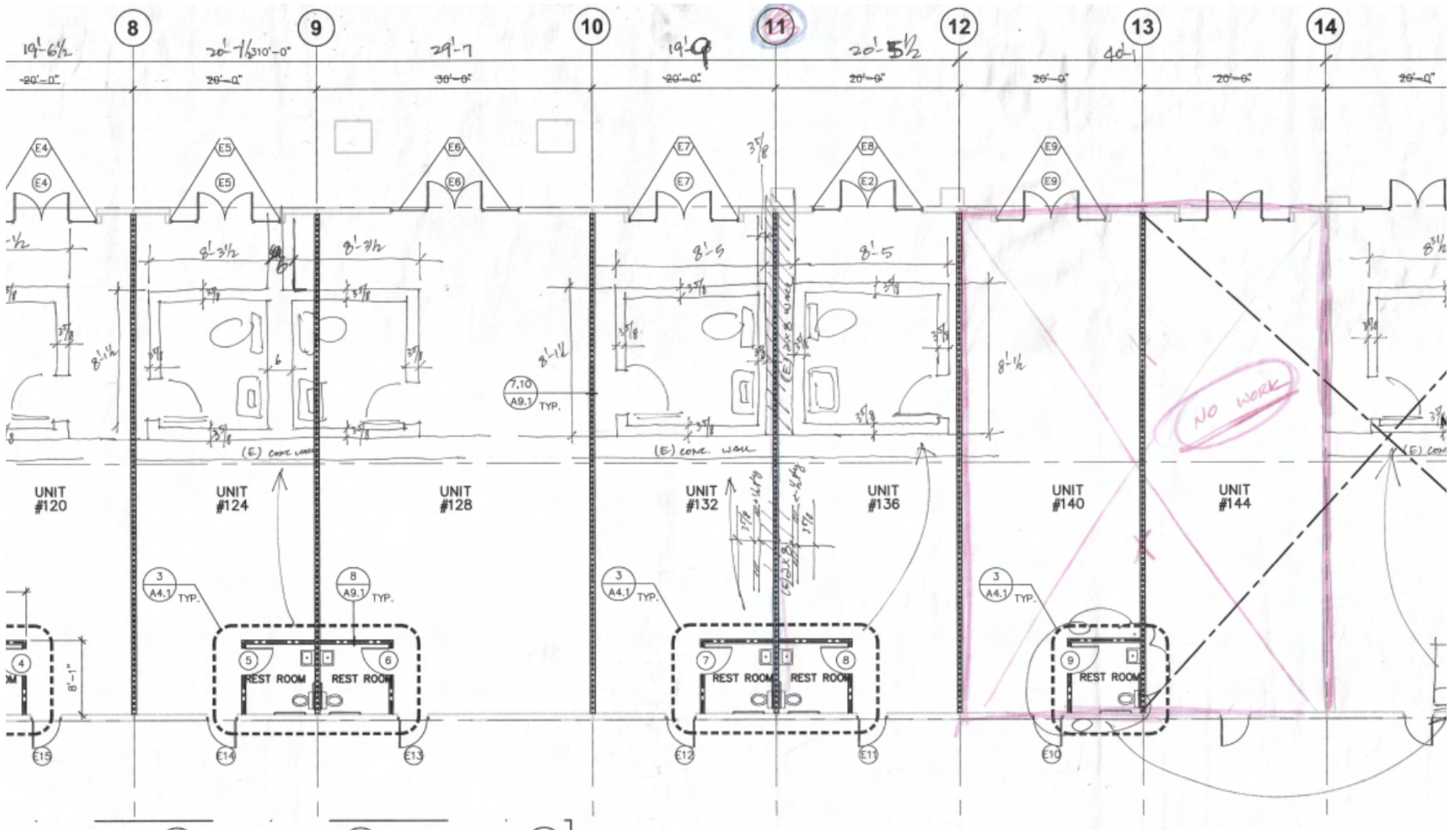

**MIKE PRIOLO**

O: 408.439.8875  
 mike.priolo@svn.com  
 CalDRE #01878385

# FLOOR PLANS 8630

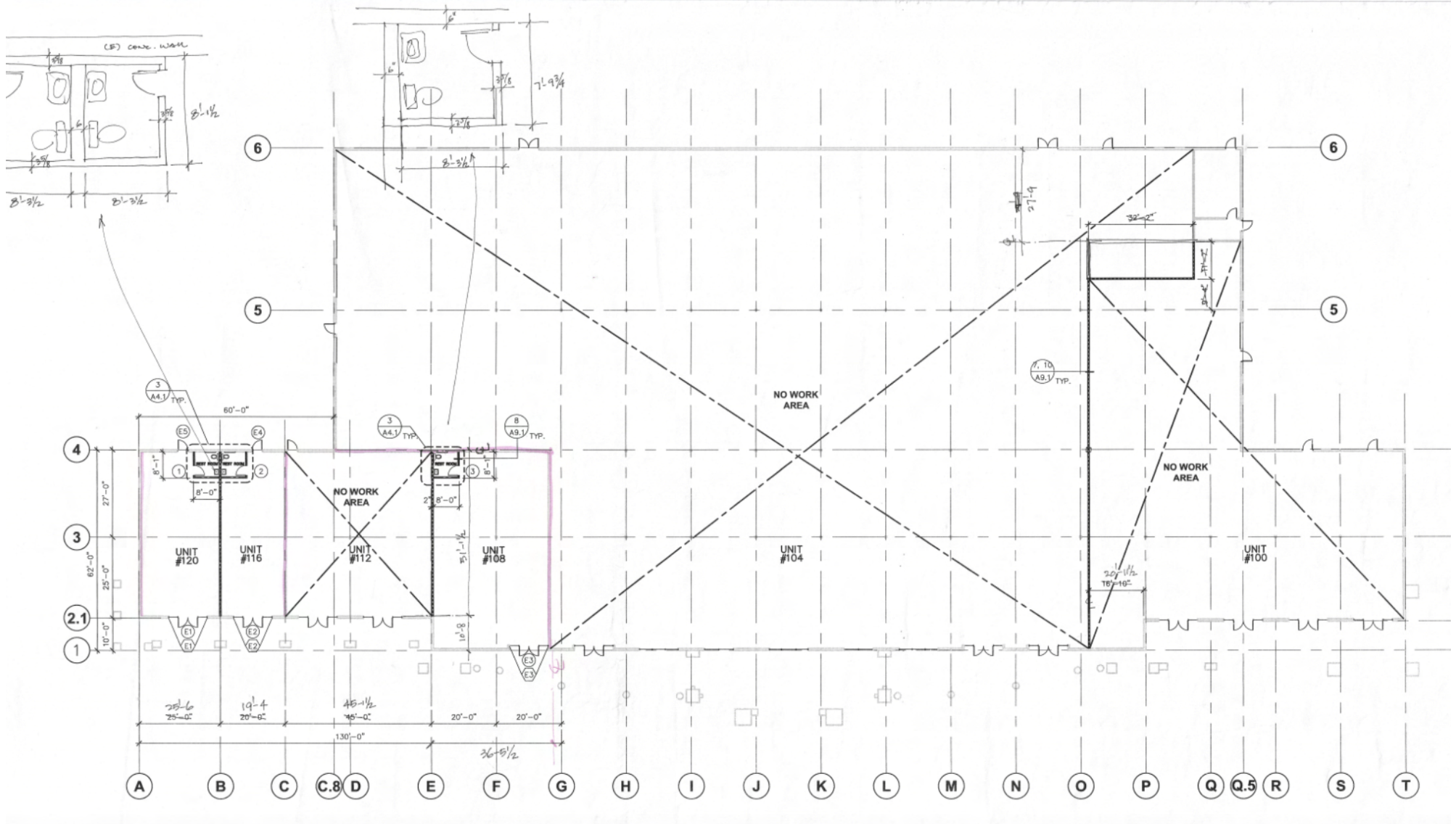

**MIKE PRIOLO**

O: 408.439.8875

mike.priolo@svn.com

CalDRE #01878385

# FLOOR PLANS 8640

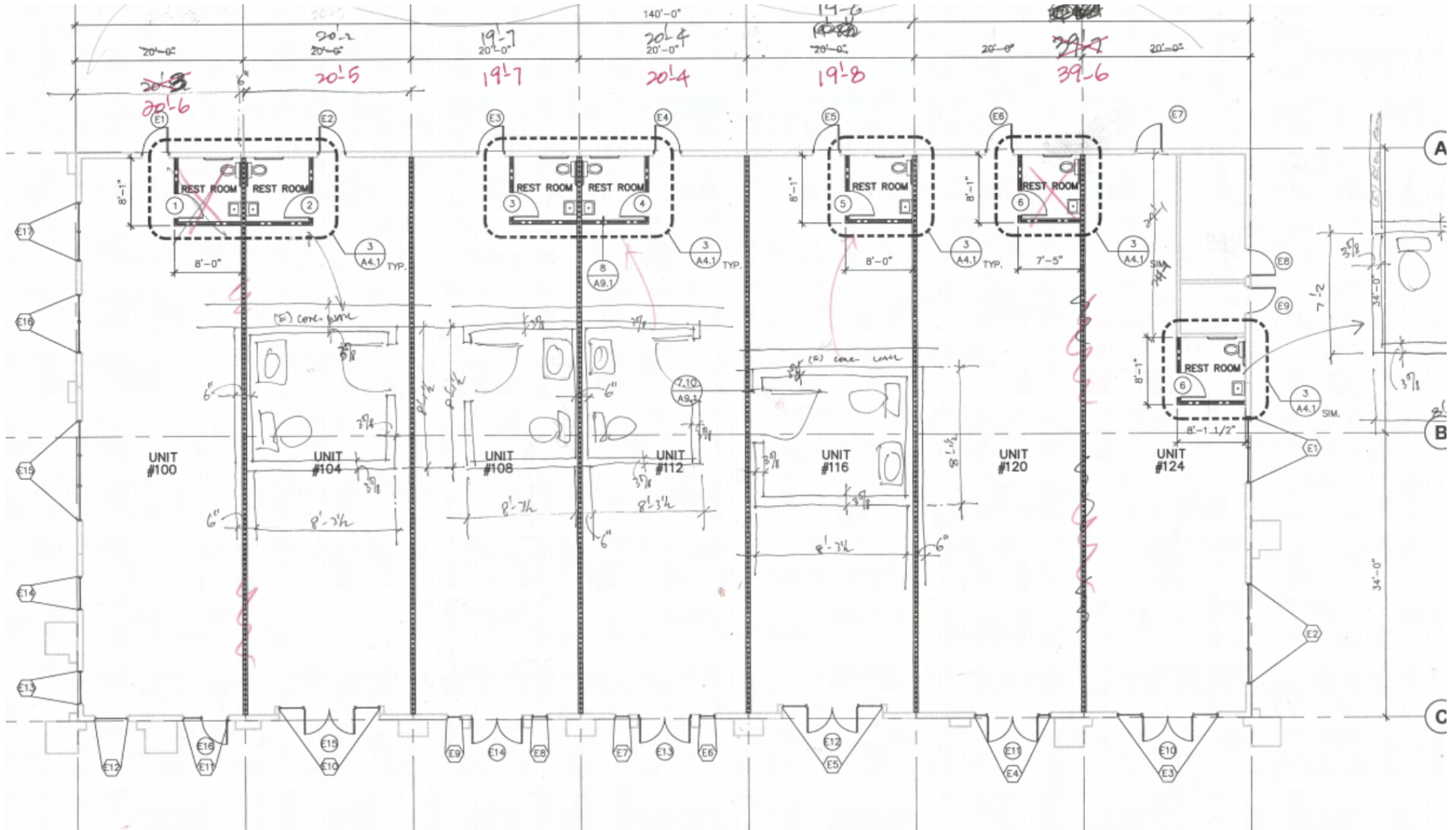

**MIKE PRIOLO**

O: 408.439.8875

mike.priolo@svn.com

CalDRE #01878385

# FLOOR PLANS 8650

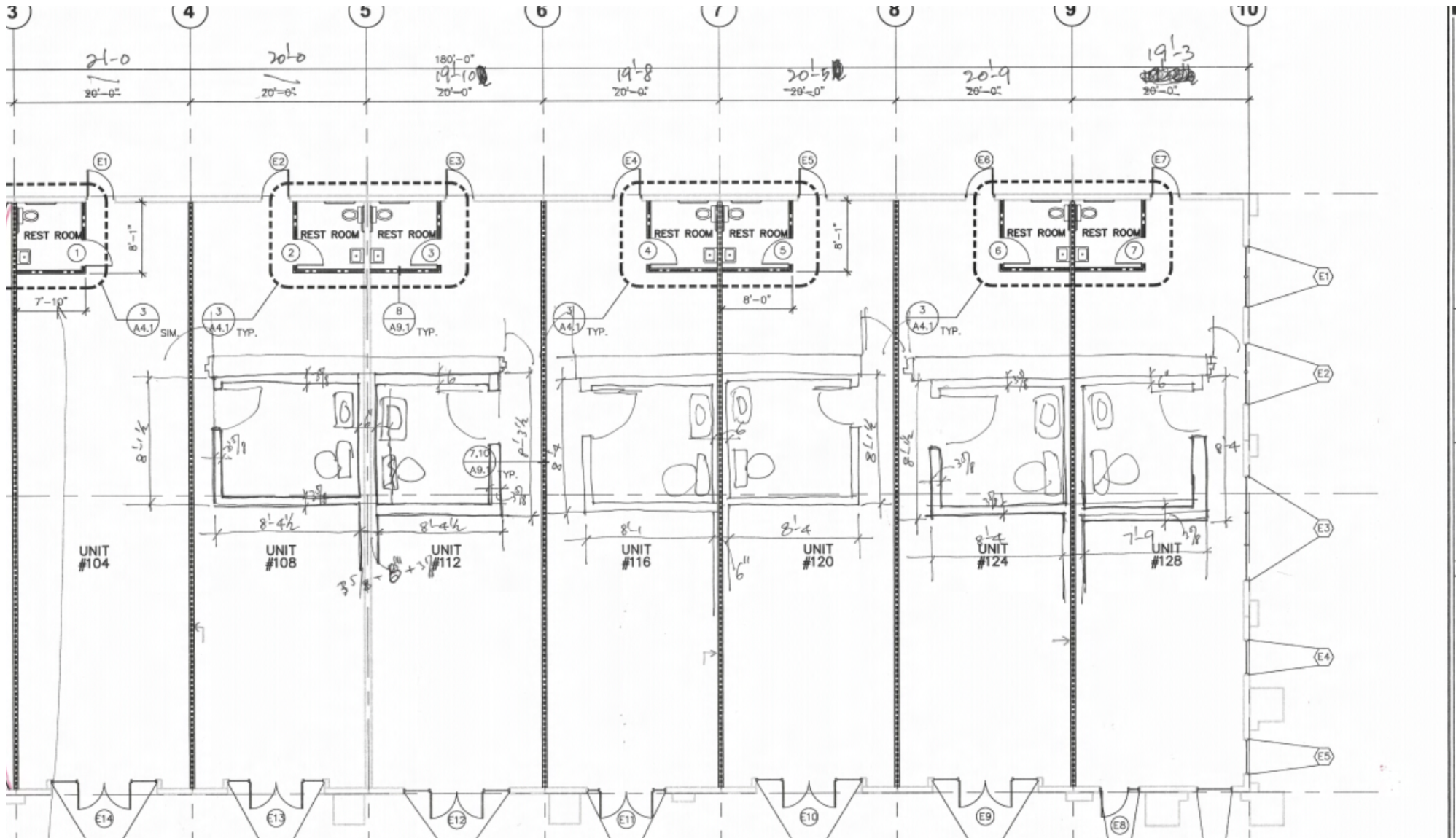

**MIKE PRIOLO**

O: 408.439.8875

mike.priolo@svn.com

CalDRE #01878385

## AVAILABLE SPACES

### LEASE INFORMATION

<b>LEASE TYPE:</b>	NNN	<b>LEASE TERM:</b>	Negotiable
<b>TOTAL SPACE:</b>	1,005 - 26,925 SF	<b>LEASE RATE:</b>	\$1.80 - \$2.00 SF/month

### AVAILABLE SPACES

SUITE	TENANT	SIZE (SF)	LEASE TYPE	LEASE RATE	DESCRIPTION
8620 Suite 100	Available	3,009 SF	NNN	\$1.80 - 2.00 SF/month	-
8620 Suite 116	Available	1,148 SF	NNN	\$1.80 - 2.00 SF/month	Old Salad Master Space - Suite has Food Use Build-Out!
8620 Suite 120	Available	1,094 SF	NNN	\$1.80 - 2.00 SF/month	-
8620 Suite 124	Available	1,155 SF	NNN	\$1.80 - 2.00 SF/month	-
8620 Suite 128	Available	1,657 SF	NNN	\$1.80 - 2.00 SF/month	-
8620 Suite 132	Available	1,106 SF	NNN	\$1.80 - 2.00 SF/month	-
8620 Suite 136	Available	1,146 SF	NNN	\$1.80 - 2.00 SF/month	-
8620 Suite 140	Available	2,245 SF	NNN	\$1.80 - 2.00 SF/month	-
8620 Suite 148	Available	2,247 SF	NNN	\$1.80 - 2.00 SF/month	End Cap Space - Excellent for a Restaurant/Food Use
8630 Suite 120	Available	1,326 SF	NNN	\$1.80 - 2.00 SF/month	-
8630 Suite 112	Available	2,363 SF	NNN	\$1.80 - 2.00 SF/month	-
8630 Suite 116	Available	1,005 SF	NNN	\$1.80 - 2.00 SF/month	-

#### MIKE PRIOLO

O: 408.439.8875

mike.priolo@svn.com

CalDRE #01878385

# AVAILABLE SPACES

SUITE	TENANT	SIZE (SF)	LEASE TYPE	LEASE RATE	DESCRIPTION
8630 Suite 104	Available	26,925 SF	NNN	Negotiable	Anchor Space, TI Dollars Available, Divisible, Two Loading Docs
8640 Suite 116	Available	1,337 SF	NNN	\$1.80 - 2.00 SF/month	-
8640 Suite 112	Available	1,383 SF	NNN	\$1.80 - 2.00 SF/month	-
8640 Suite 100	Available	2,782 SF	NNN	\$1.80 - 2.00 SF/month	-
8640 Suite 120	Available	2,476 SF	NNN	\$1.80 - 2.00 SF/month	-
8650 Suite 128	Available	1,309 SF	NNN	\$1.80 - 2.00 SF/month	-
8650 Suite 120	Available	1,388 SF	NNN	\$1.80 - 2.00 SF/month	-
8650 Suite 116	Available	1,337 SF	NNN	\$1.80 - 2.00 SF/month	-
8650 Suite 108	Available	1,360 SF	NNN	\$1.80 - 2.00 SF/month	-
8650 Suite 104	Available	1,428 SF	NNN	\$1.80 - 2.00 SF/month	Second Generation Optometry Space

**MIKE PRIOLO**

O: 408.439.8875  
 mike.priolo@svn.com  
 CalDRE #01878385

# DEMOGRAPHICS - 5 MILE RADIUS

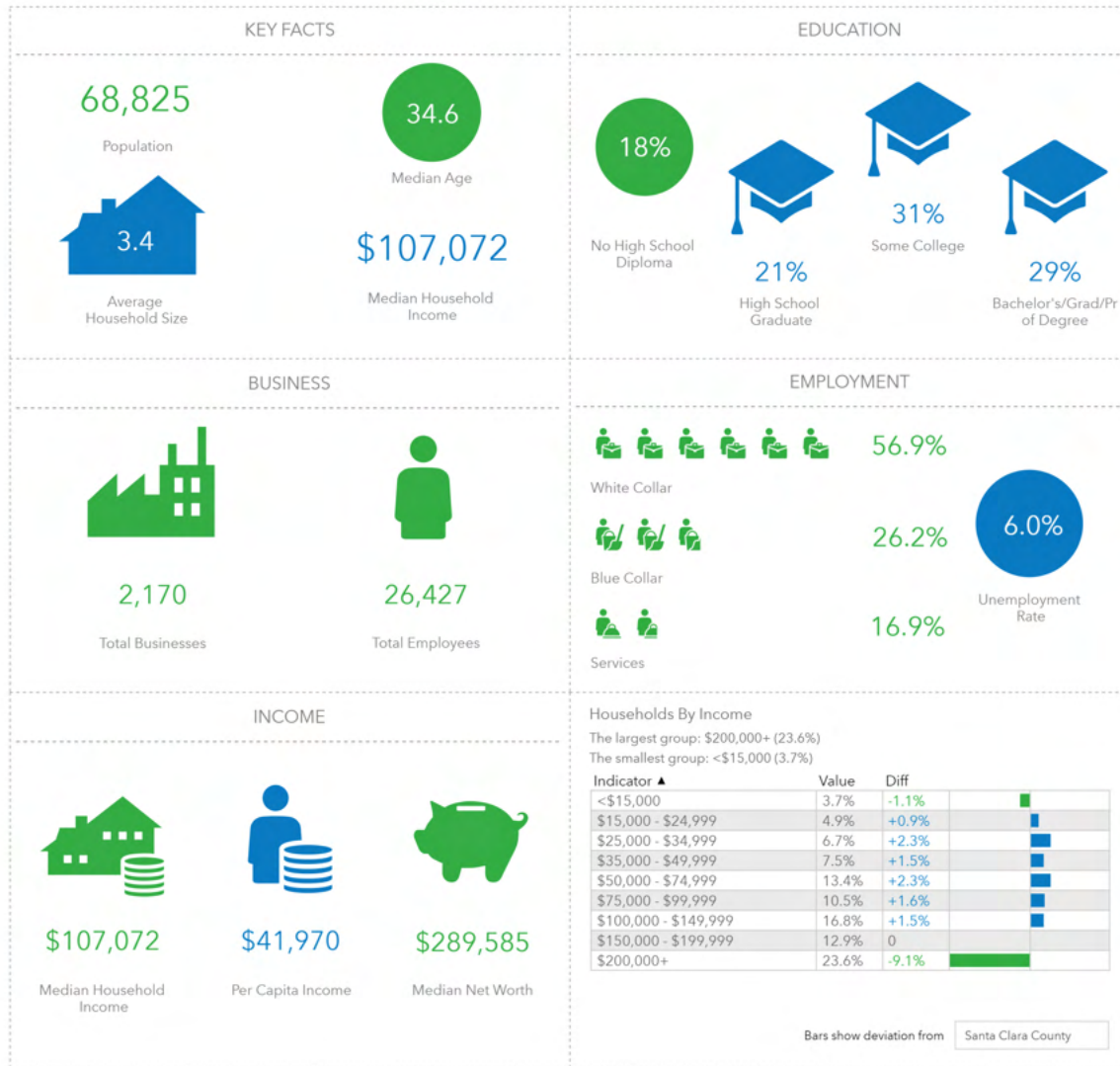

This infographic contains data provided by Esri, Esri and Data Axle. The vintage of the data is 2021, 2026.

© 2022 Esri

## MIKE PRIOLO

O: 408.439.8875

mike.priolo@svn.com

CalDRE #01878385