

3RD FLOOR - DIMENSION PLAN

1/8"=1'-0"

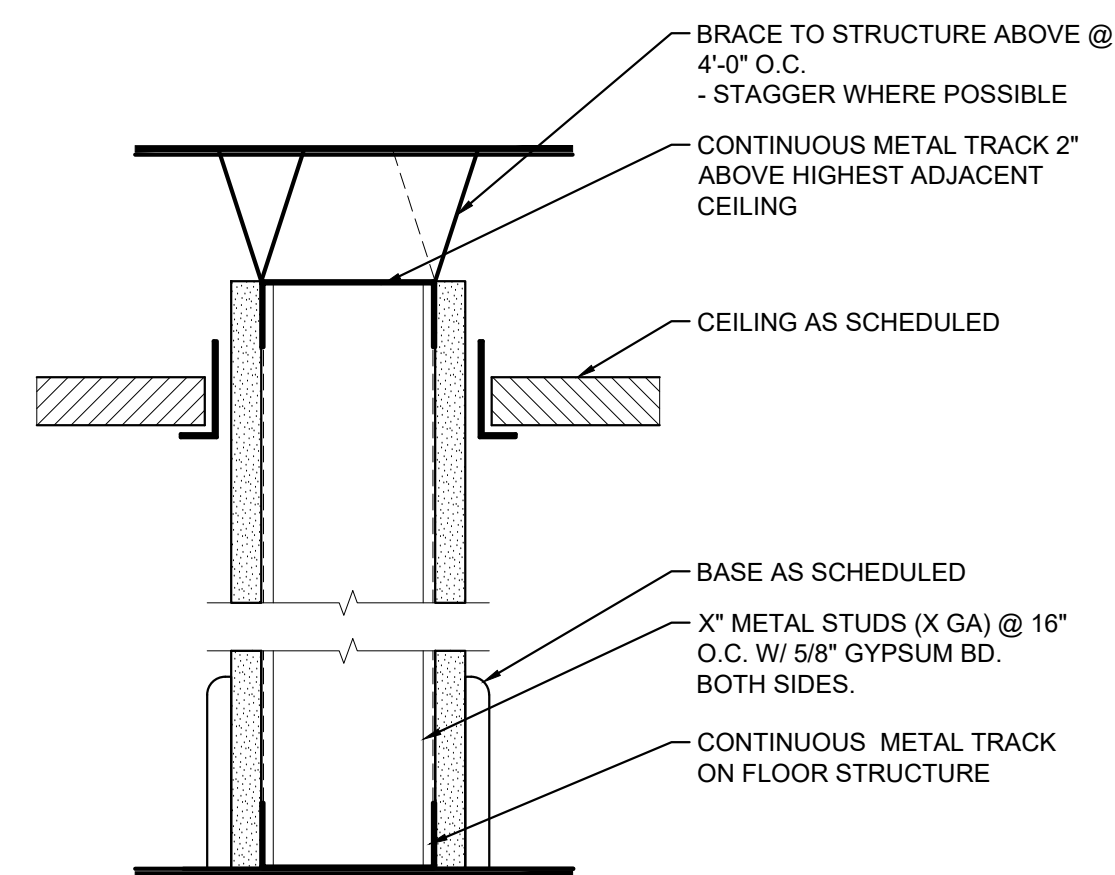

STANDARD PARTITION

3" = 1'-0"

1
A131

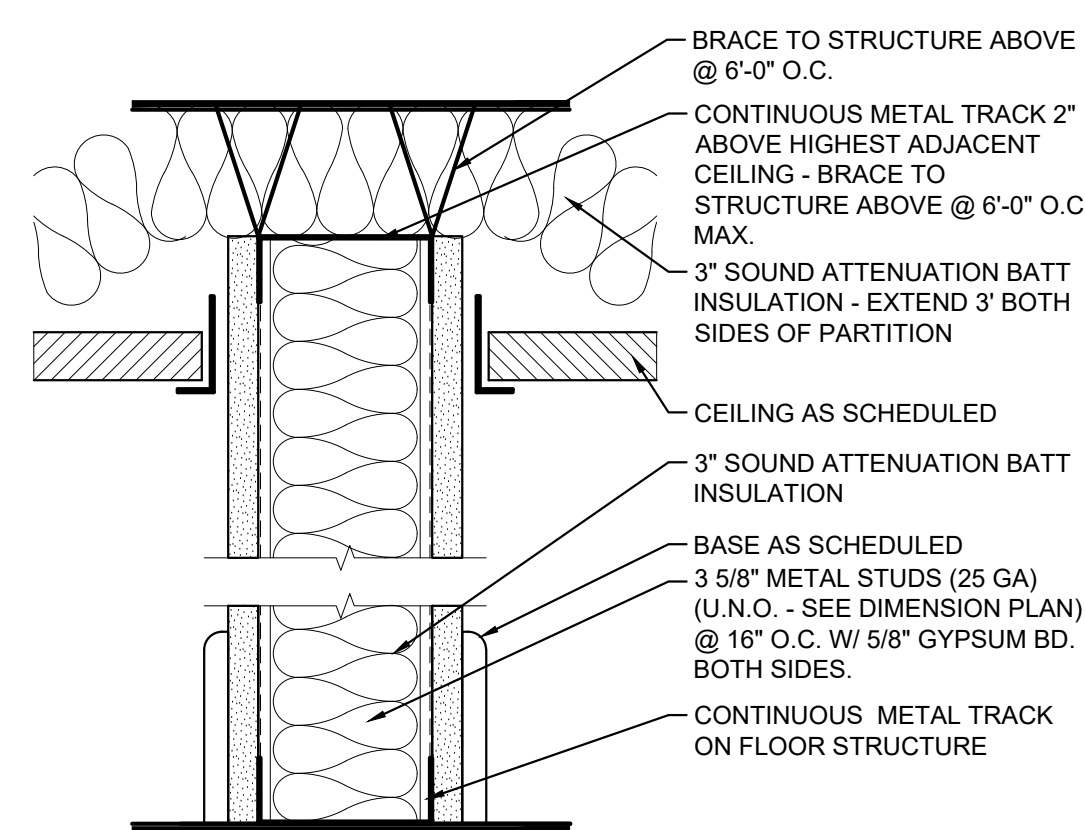

SOUND PARTITION ABOVE CEILING

3" = 1'-0"

2
A131

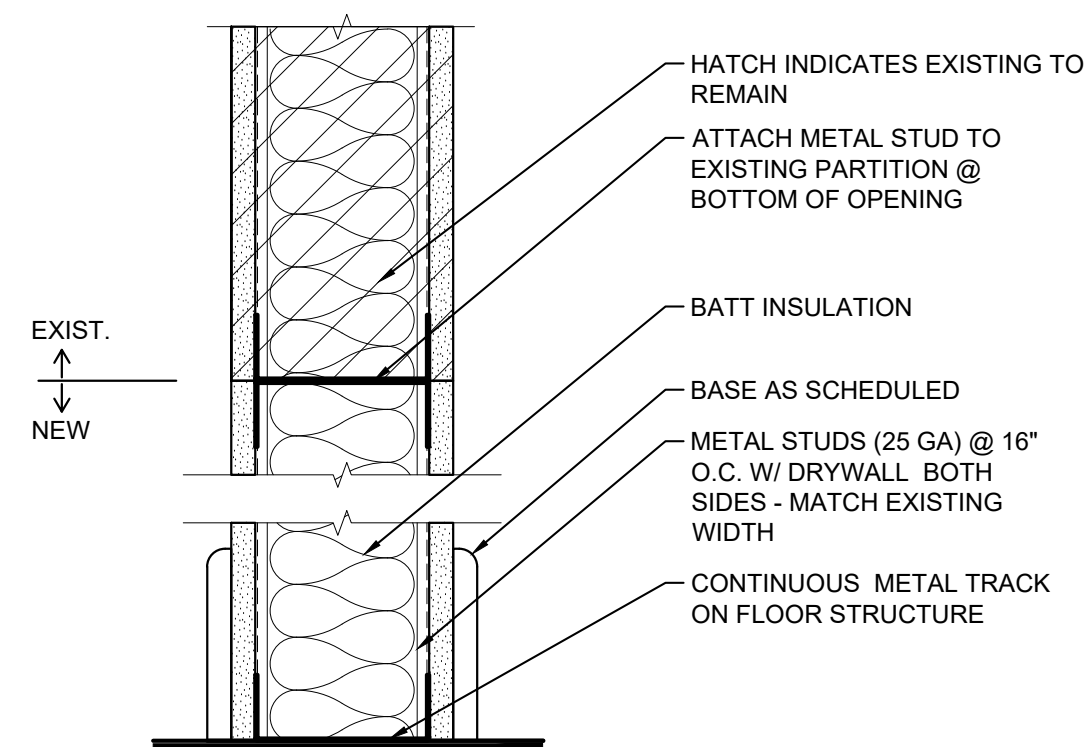

NEW INFILL SOUND PARTITION AT EXISTING WALL OPENING

3" = 1'-0"

3
A131

PARTITION @ EXTERIOR WINDOW

3" = 1'-0"

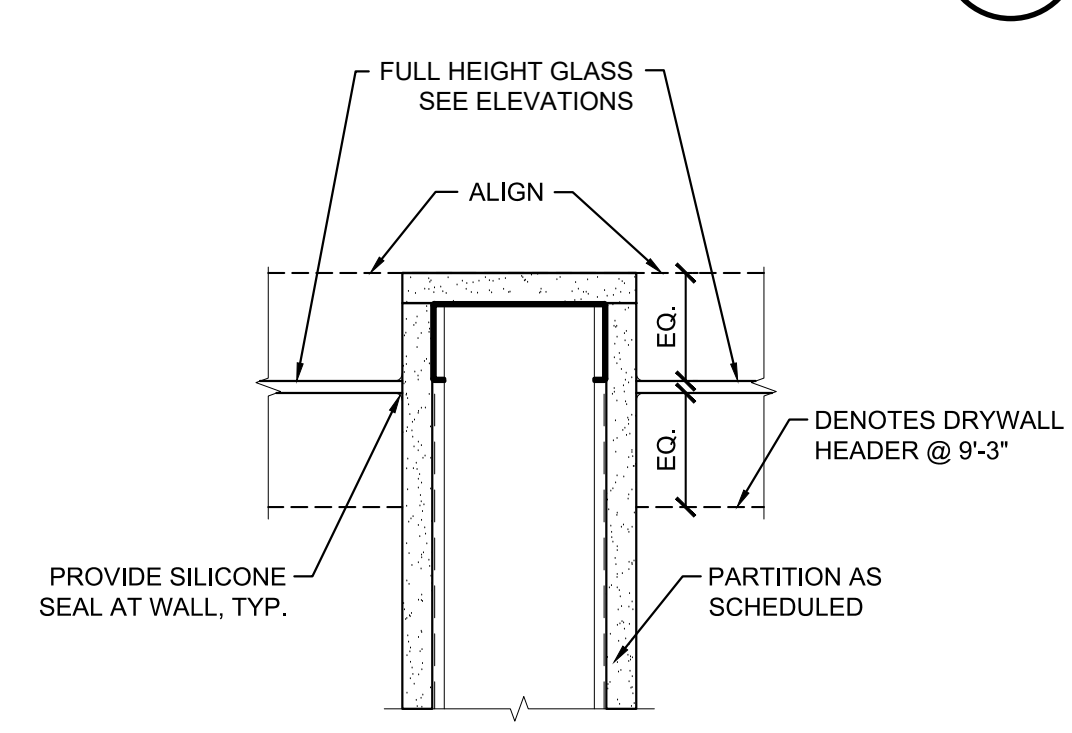

PARTITION @ INTERIOR WINDOW

3" = 1'-0"

4
A131

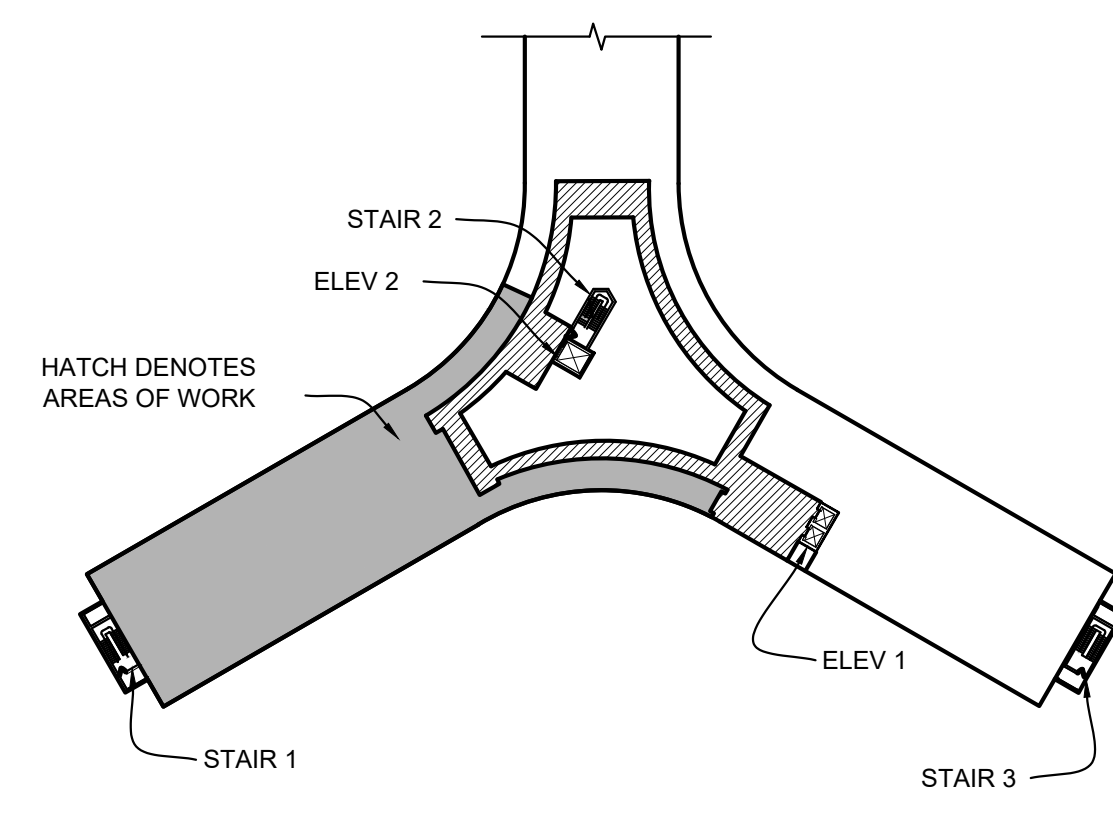

PROJECT KEY PLAN

NOT TO SCALE