

# GASWORX

Tampa, Florida



*Move in ready suites coming soon*

# The Lifestyle Workplace



## AVAILABLE SPACE

Floor 5	2,755 SF
Floor 5	4,871 SF
Floor 6	4,620 SF



## BUILDING AMENITIES

- Rooftop deck
- Tenant terraces
- Conference facility
- Lobby café & bar
- Esplanade joining 35,000 SF dining & retail marketplace
- Grow Financial Credit Union



## PARKING

- Adjacent structured parking
- EV charging stations
- Secure bicycle parking
- Street parking



## BUILDING SPECS

- 6-story office/retail bldg
- 95,000 SF total
- 12' clear height (10' with drop ceiling)
- LEED Certified



## LOCATION

- 1301 E 4th Avenue
- Tampa, FL 33605
- Adjacent to new city park & new TECO Streetcar stop

# FLOOR 5

## SPEC FLOOR PLAN

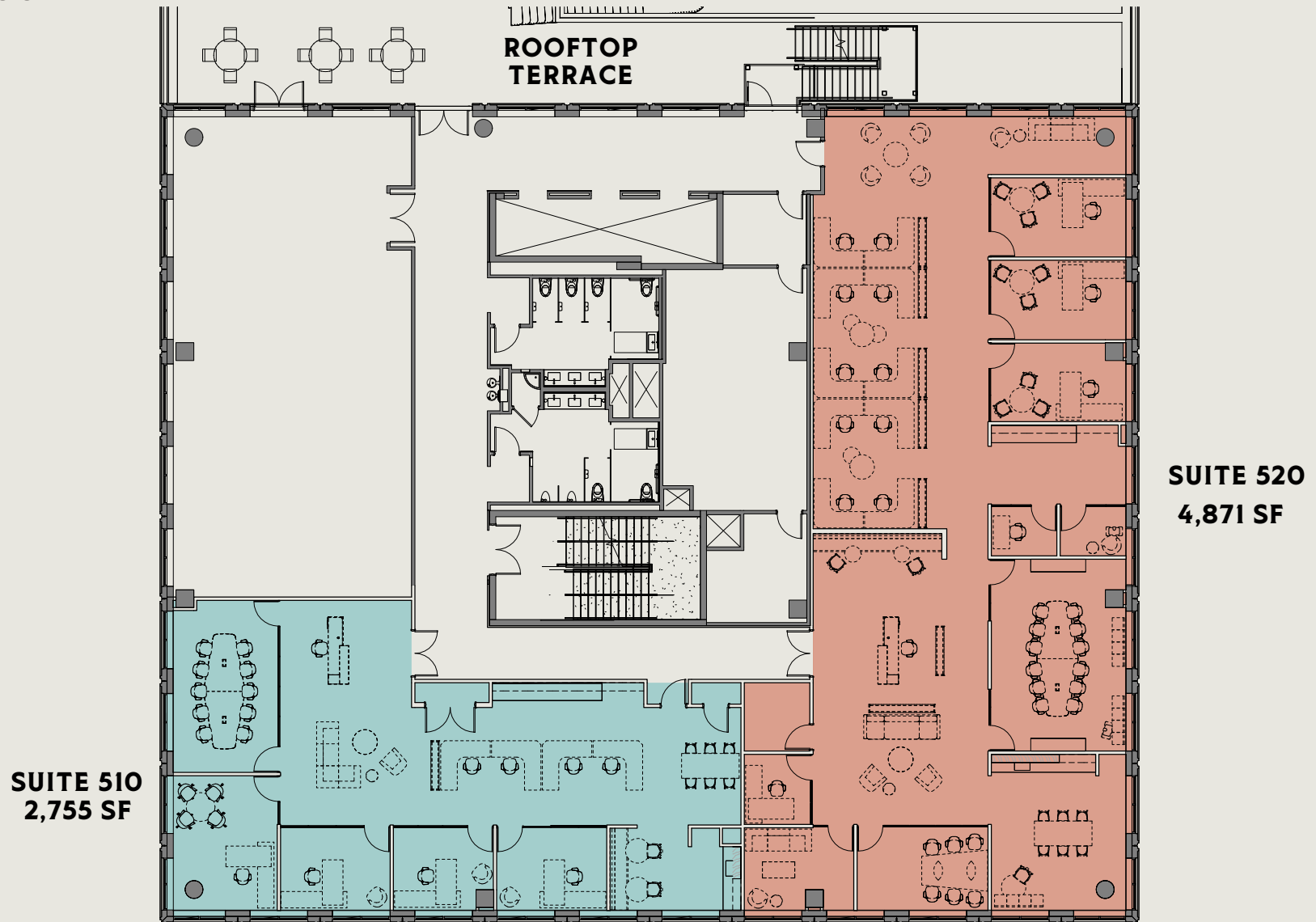

FURNITURE NOT INCLUDED

# FLOOR 6

## SPEC FLOOR PLAN

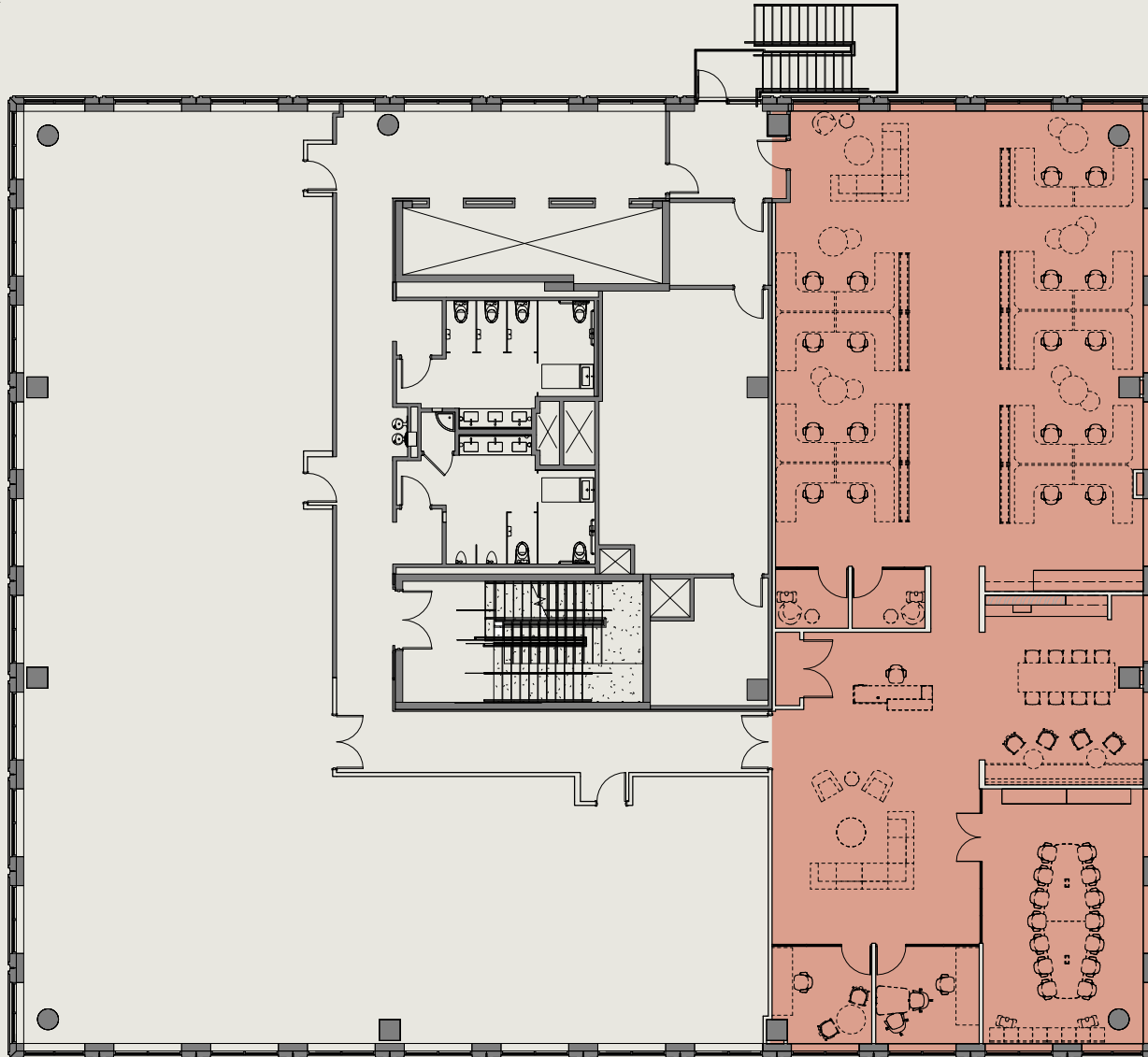

**SUITE 610**  
**4,620 SF**

FURNITURE NOT INCLUDED

# INTERIOR VIBES

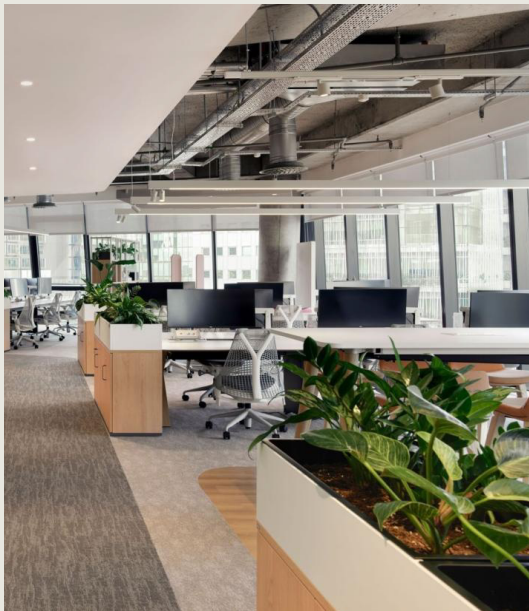

# FINISHES THROUGHOUT



# ELEVATIONS



GRIDDED BLACK FRAME

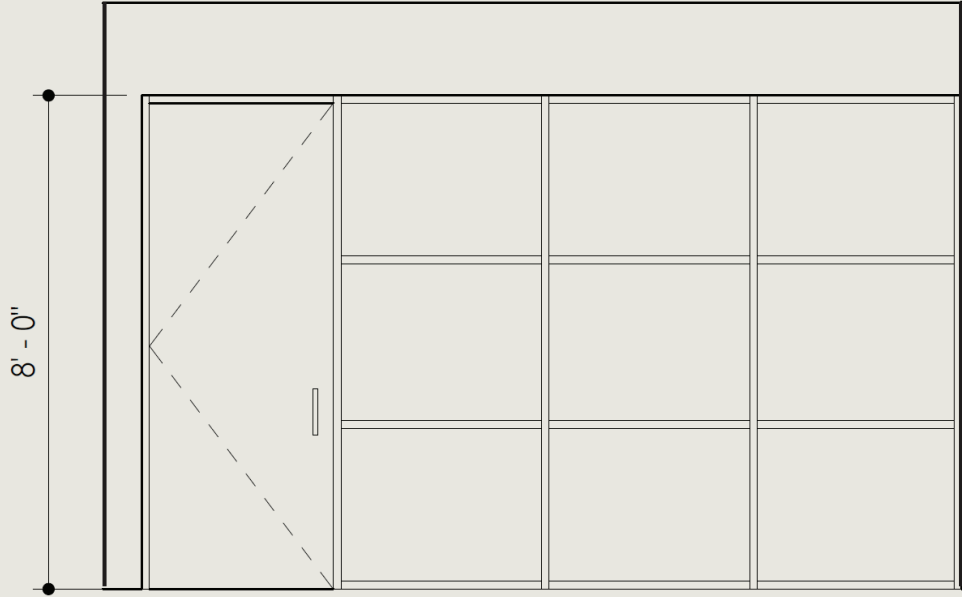

TYP. OFFICE FRONT ELEVATION

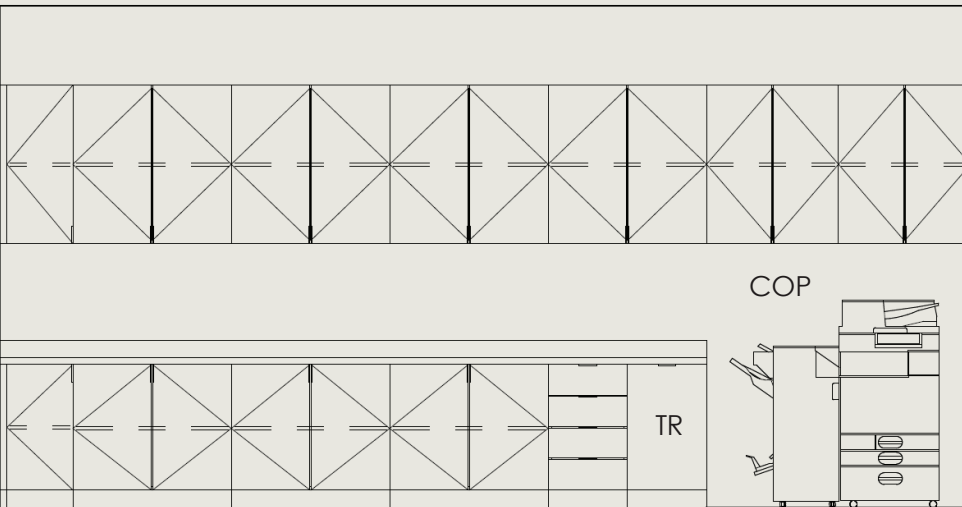

TYP. BIZ HUB ELEVATION

# BREAK ROOM FINISHES

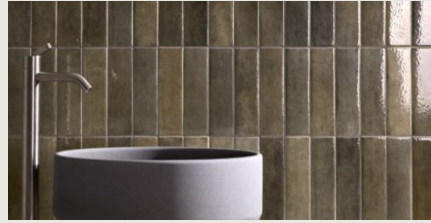

UPPER CABINETS + SHELF

BACKSPLASH  
MIX "FENDI" AND "OFF  
WHITE" 2.5"X9" HAND  
GLAZED TILES IN VERTICAL  
STACK PATTERN. LEFT  
IMAGE SHOWS RANGE  
OF COLOR VARIATION



COUNTERTOPS



SEALED CONCRETE

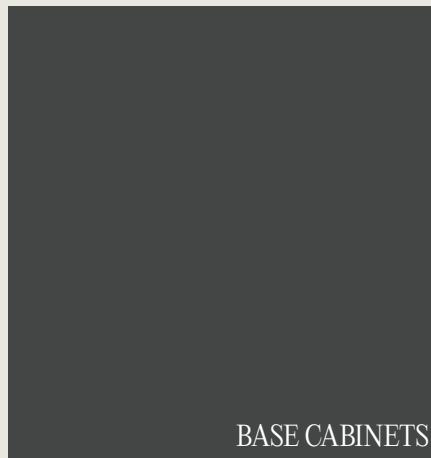

BASE CABINETS

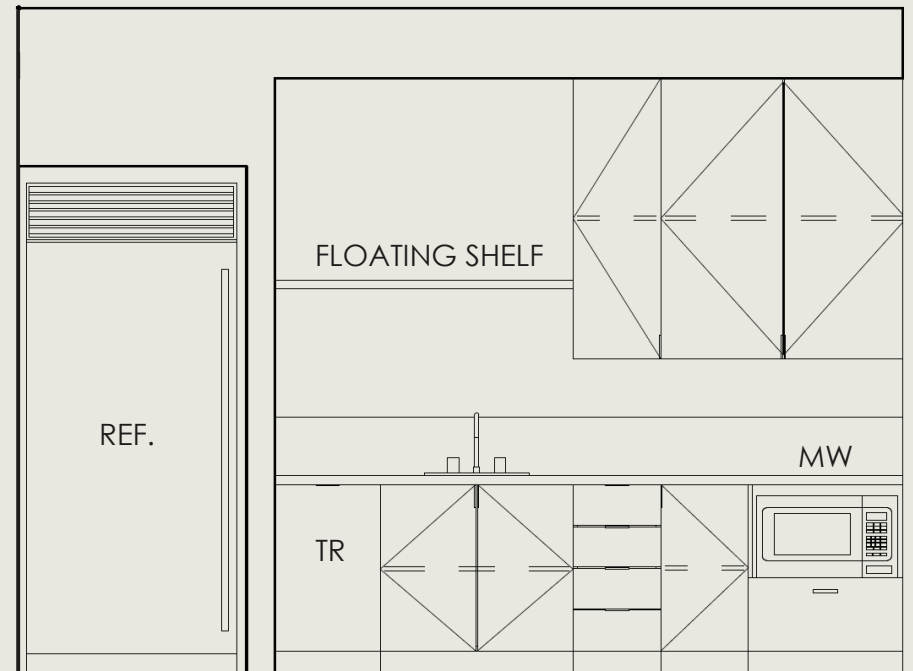

# CEILING PLAN



**LEVEL 5**

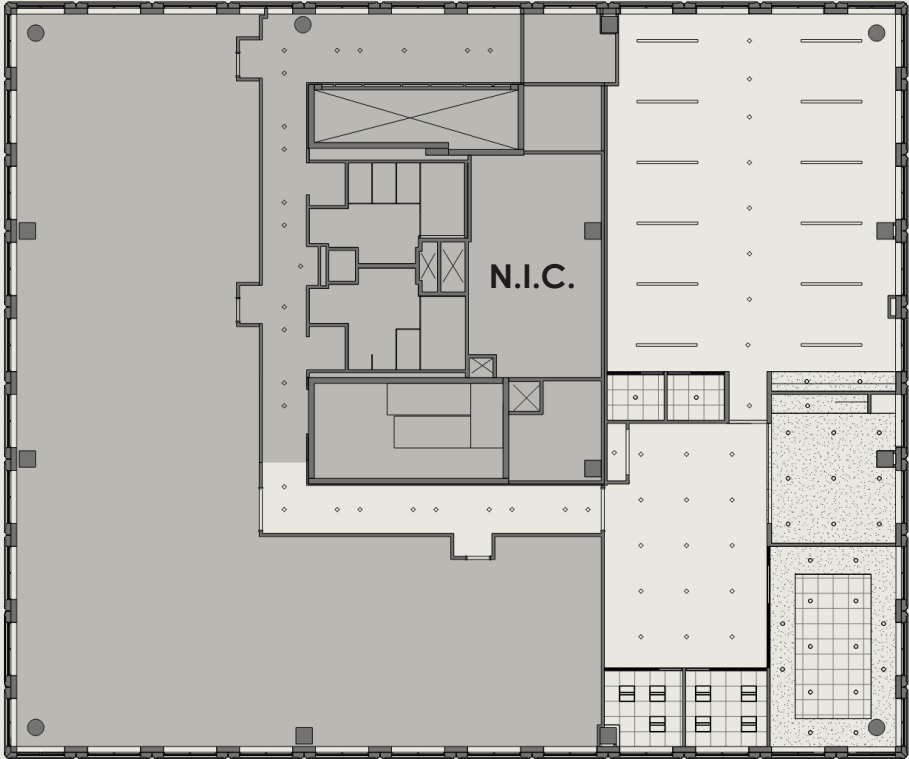

**LEVEL 6**

**LEGEND**



EXPOSED CEILING



GYP CEILING

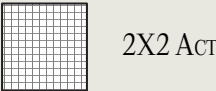

2X2 ACT



**2X2 LAY-IN**  
Typ. At Offices

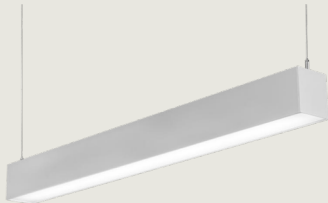

**LINEAR PENDANT**  
Open Office Areas



**CYLINDAR PENDANT**  
Typ. At All Exposed  
Ceiling Locations



**4" DOWNLIGHT**  
Typ. At Conference And  
Break Rooms

# GASWORX



**JIM MOLER**

[jim.moler@jll.com](mailto:jim.moler@jll.com)

+1 813 387 1308

**DEANA BEER**

[deana.beer@jll.com](mailto:deana.beer@jll.com)

+1 813 387 1298

[gasworx.com](http://gasworx.com)

Although information has been obtained from sources deemed reliable, JLL does not make any guarantees, warranties or representations, express or implied, as to the completeness or accuracy as to the information contained herein. Any projections, opinions, assumptions or estimates used are for example only. There may be differences between projected and actual results, and those differences may be material. JLL does not accept any liability for any loss or damage suffered by any party resulting from reliance on this information. If the recipient of this information has signed a confidentiality agreement with JLL regarding this matter, this information is subject to the terms of that agreement.

©2026 Jones Lang LaSalle Brokerage, Inc. All rights reserved.