

Muti-Tenant Industrial/Flex/R&D/Office | For Lease

CBRE

# Charter Business Park

San Jose, CA 95136

[www.cbre.com/siliconvalley](http://www.cbre.com/siliconvalley)

±1,296 SF - ±2,592 SF





## Property Features

- + Mixed-use development: R&D, Industrial, Office and some Retail
- + Strategic location with proximity to Highways 87, 101 and 85
- + 0.5 Miles to Caltrain Capitol Station, 1 mile from Capitol Expressway Light Rail Station
- + Located in the highly desirable Charter Business Park across the street from Communication Hill

### Current Availability

3710 Charter Park Dr, Units B & C	2 Roll Up Doors, 2 Offices, 2 Restrooms	±2,592 SF
3851 Charter Park Dr, Unit Q	1 Office, 1 Bathroom, 1 Roll Up Door	±1,397 SF
3750 Charter Park Dr, Unit D	1 Office, 1 Bathroom, 1 Roll Up Door	±1,296 SF
3728 Charter Park Dr, Unit C	1 Office, 1 Bathroom, 1 Roll Up Door	±1,296 SF

**3710 Charter Park Dr**  
**UNITS B & C**  
±2,592 SF

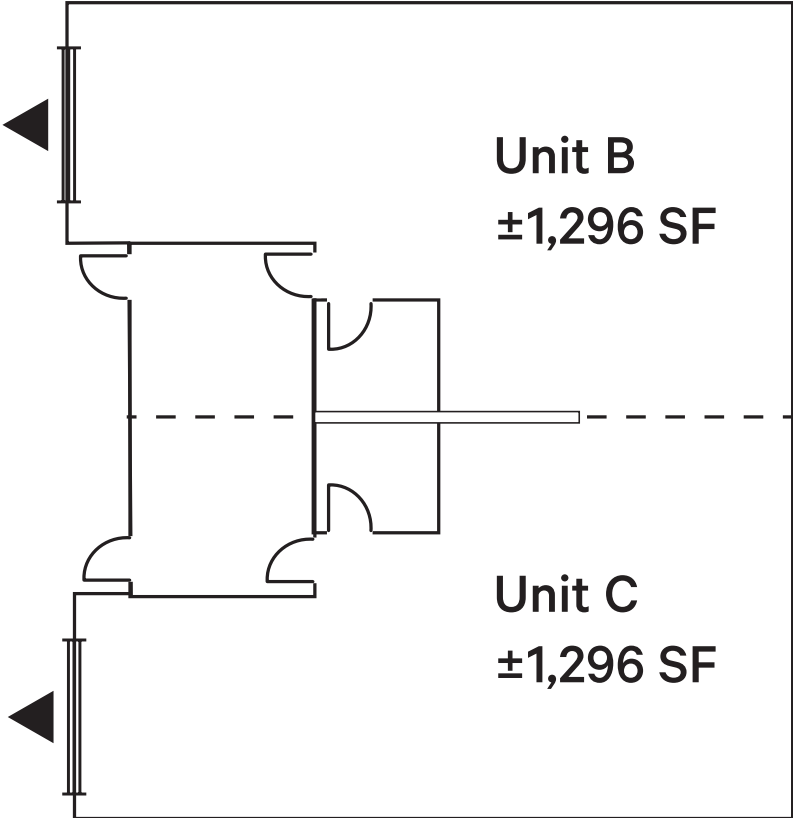

- + Sprinklered
- + 85% Warehouse
- + 15% Office
- + 2 Roll Up Doors
- + 2 Offices
- + 2 Restrooms
- + Market Ready
- + Available May 1, 2026

**3851 Charter Park Dr.**

**UNIT Q**

±1,397 SF

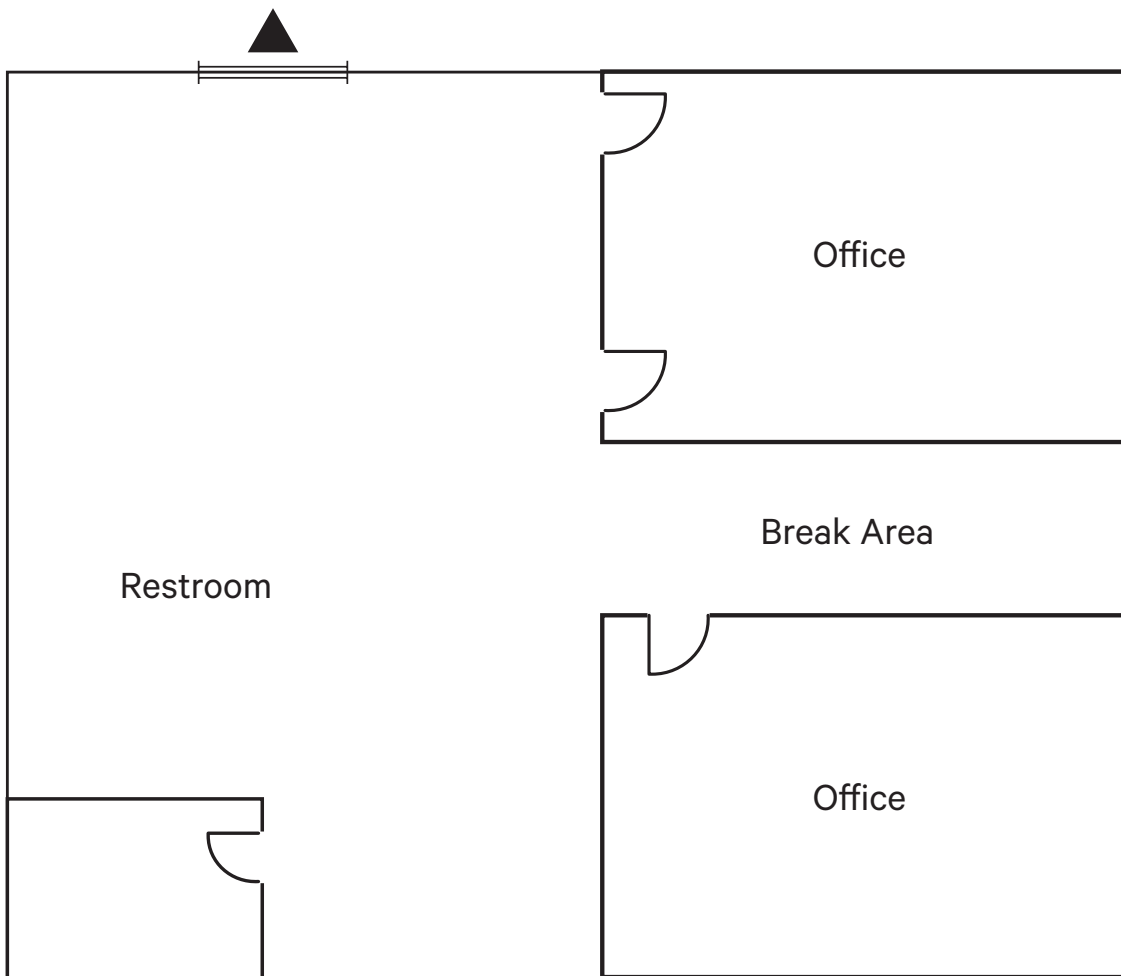

- +1 Office
- +1 Bathroom
- +1 Roll Up Door (10' x 10')
- + Balance Warehouse
- + Can be combined with Unit P for ±2,794 SF

**3750 Charter Park Dr.**  
**UNIT D**  
±1,296 SF

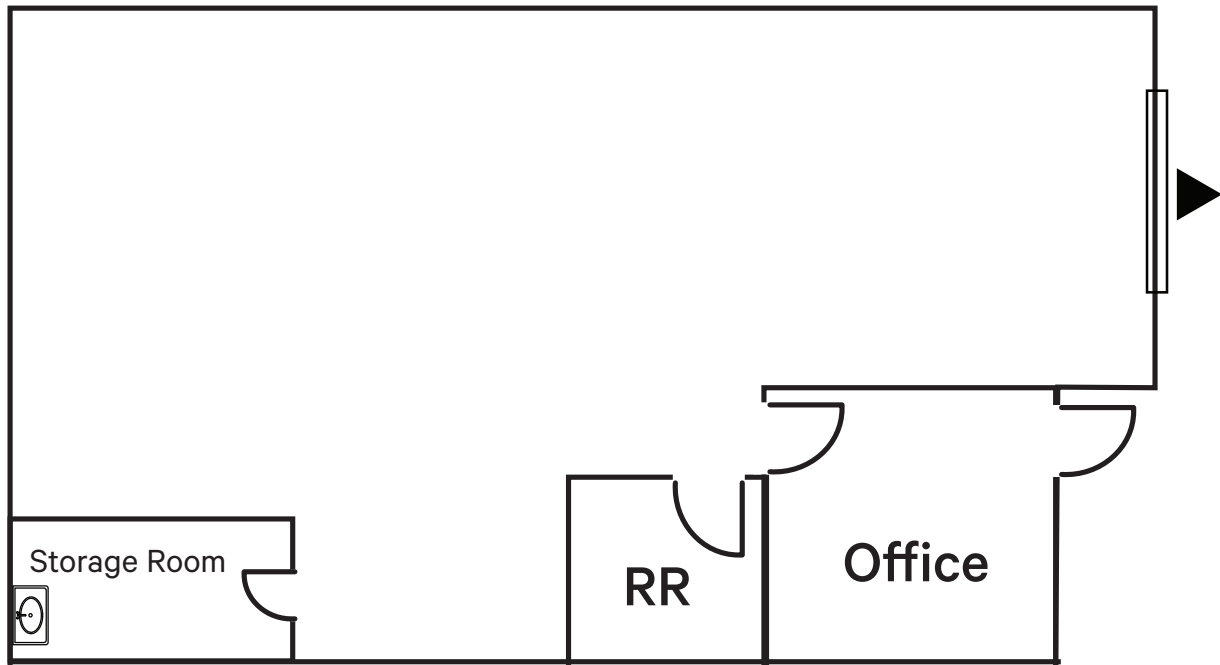

- +1 Office
- +1 Bathroom
- +1 Roll Up Door

**3728 Charter Park Dr.**  
**UNIT C**  
±1,296 SF

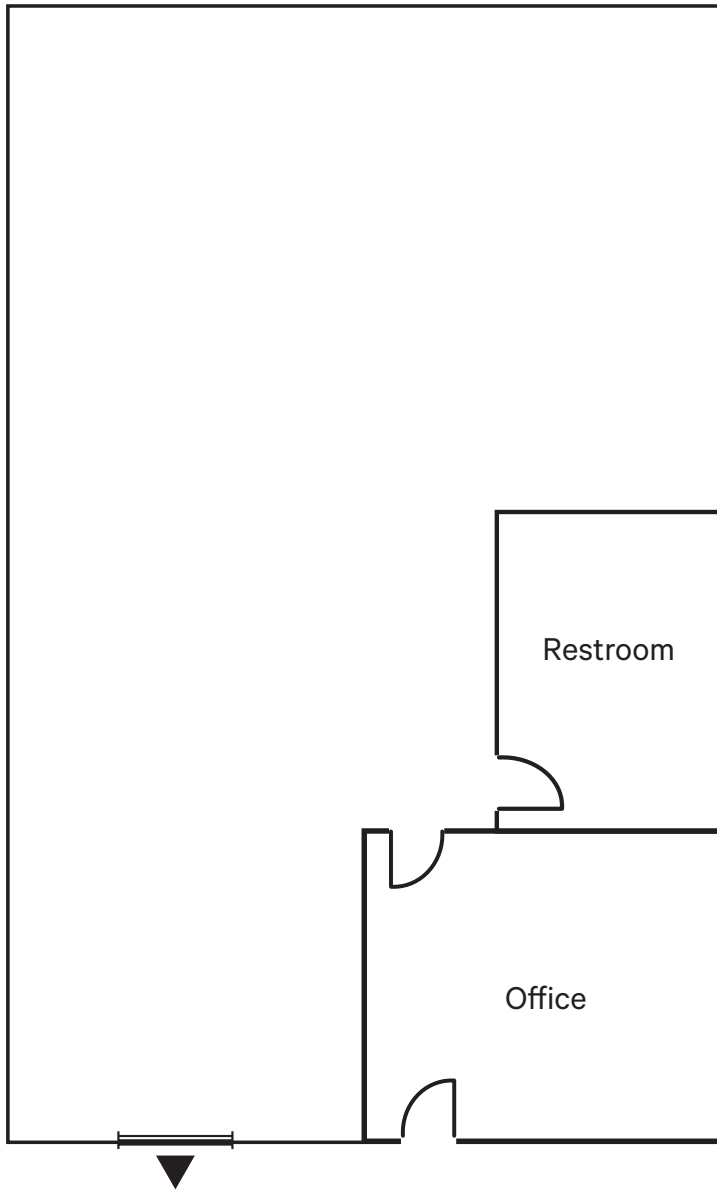

+1 Office  
+1 Bathroom

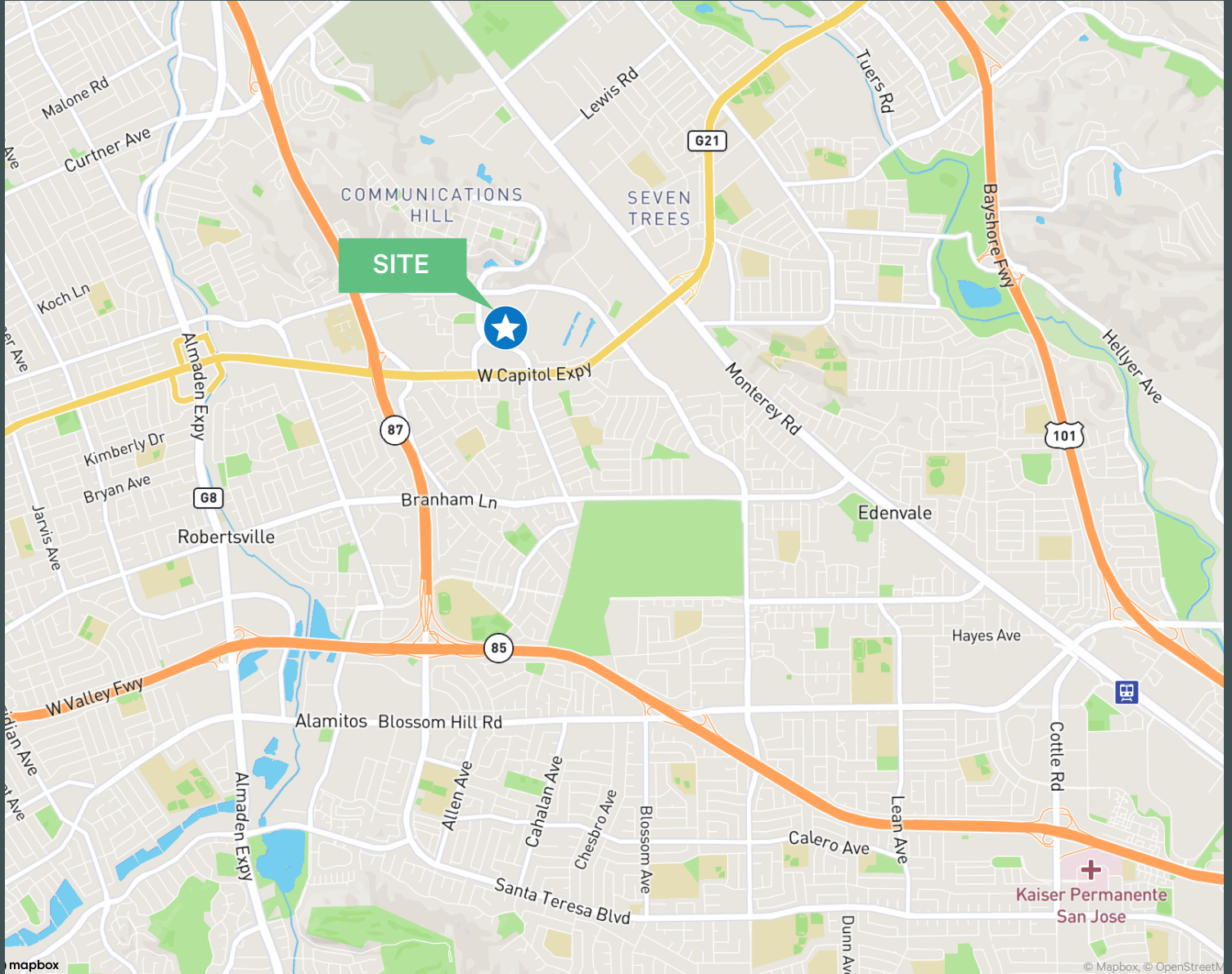

## Contact Us

**Terence Fox**

Vice President  
+1 408 591 2901  
terence.fox@cbre.com  
Lic. 02068798

**Brian Matteoni**

Executive Vice President  
+1 408 453 7407  
brian.matteoni@cbre.com  
Lic. 00917296

© 2026 CBRE, Inc. All rights reserved. This information has been obtained from sources believed reliable but has not been verified for accuracy or completeness. CBRE, Inc. makes no guarantee, representation or warranty and accepts no responsibility or liability as to the accuracy, completeness, or reliability of the information contained herein. You should conduct a careful, independent investigation of the property and verify all information. Any reliance on this information is solely at your own risk. CBRE and the CBRE logo are service marks of CBRE, Inc. All other marks displayed on this document are the property of their respective owners, and the use of such marks does not imply any affiliation with or endorsement of CBRE. Photos herein are the property of their respective owners. Use of these images without the express written consent of the owner is prohibited.