

RETAIL SPACE FOR LEASE

NORTH PARK PLAZA AT 225 FAIRVIEW DRIVE,
BRANTFORD, ONTARIO

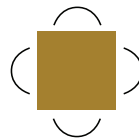

Len Goudy
Broker of Record
Goudy Real Estate Corp.
Real Estate Brokerage
(416) 830-0880



Goudy Real Estate Corp.
Real Estate Brokerage
Commercial Real Estate
Sales & Leasing

505 Hood Rd., Unit 20, Markham, ON L3R 5V6 | (905) 477-3000

DC DOV CAPITAL Asset Managers
CORPORATION Tel: (416) 633-8108

The information contained herein has been provided to Goudy Real Estate Corp. by others. We do not warrant its accuracy. You are advised to independently verify the information prior to submitting an Offer and to provide for sufficient due diligence in an offer. The information contained herein may change from time to time without notice. The property may be withdrawn from the market at any time without notice.

DETAILS

225 FAIRVIEW DRIVE



STRATEGIC LOCATION

Exceptional location located across the street from North Park Collegiate High School and Wayne Gretzky Sports Centre which, in addition to the surrounding residential community brings a lot of people to the plaza. Wayne Gretzky Sports Centre recently underwent a reconstruction and expansion and now sees over 1,000,000 visitors annually from all across the province.

North Park Plaza is located in the heart of an established residential neighbourhood providing it with a loyal customer base. Directly behind and slightly east of the Site is a combination of low and high rise residential apartment buildings contributing to the abundance of residents in the immediate area.

AVAILABLE UNITS

UNIT 2	APPROX. 990 SQ. FT.
RENT	\$35 PSF PA
TMI	\$11.03 PSF PA
UNIT 12	APPROX. 3,056 SQ. FT.
RENT	\$32 PSF PA
TMI	\$11.03 PSF PA

SITE PLAN

225 FAIRVIEW DRIVE

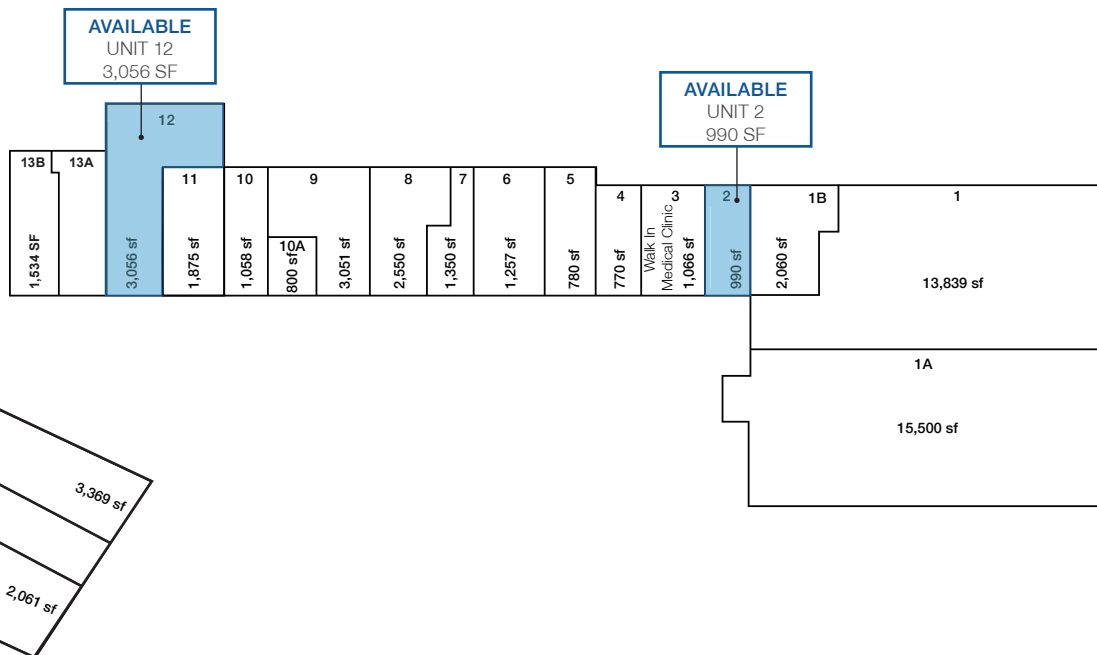

FLOOR PLAN - UNIT 2

225 FAIRVIEW DRIVE

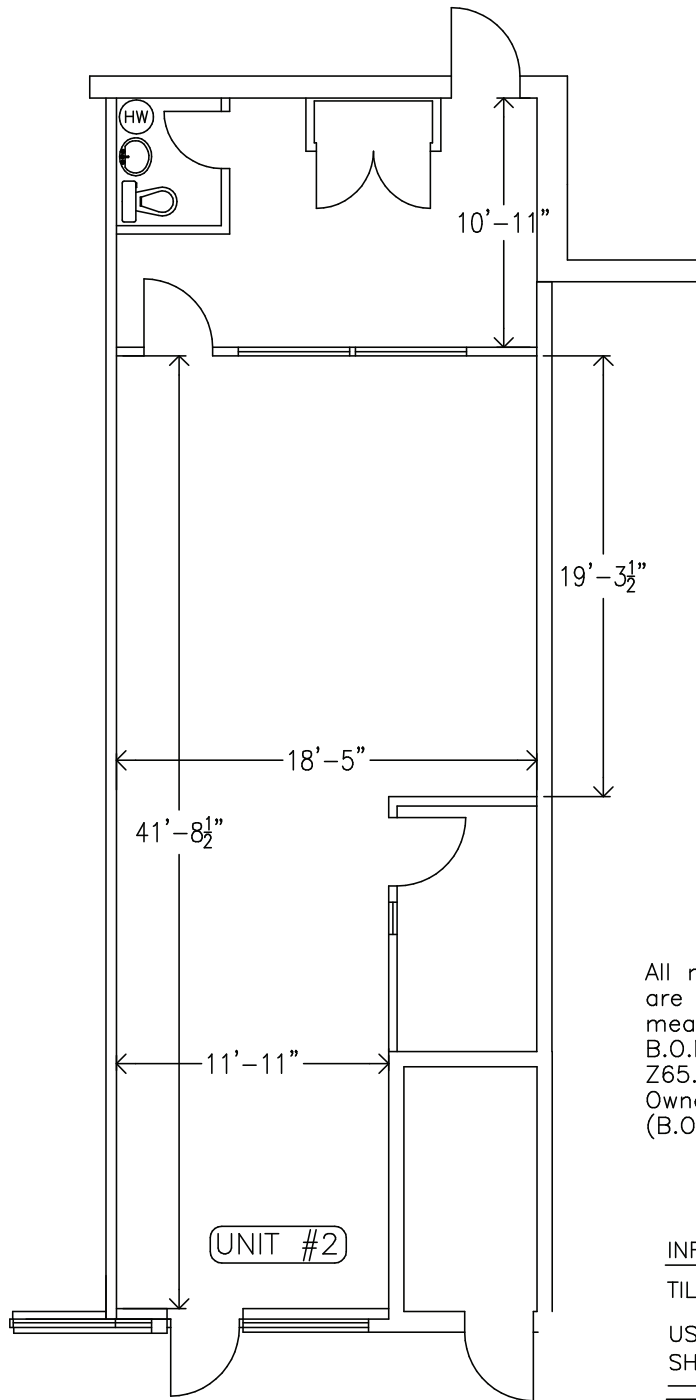

All measurements and calculations are based on the principles of measurements as set out in B.O.M.A. Standard ANSI/BOMA Z65.1-2010 Published by Building Owners and Managers Association (B.O.M.A.)

INFORMATION:

TILE HEIGHT:	9'10"
USABLE AREA:	968 SQ.FT.
SHARE OF COMMON:	22 SQ.FT.
TOTAL RENTABLE:	990 SQ.FT.

FLOOR PLAN - UNIT 12

225 FAIRVIEW DRIVE

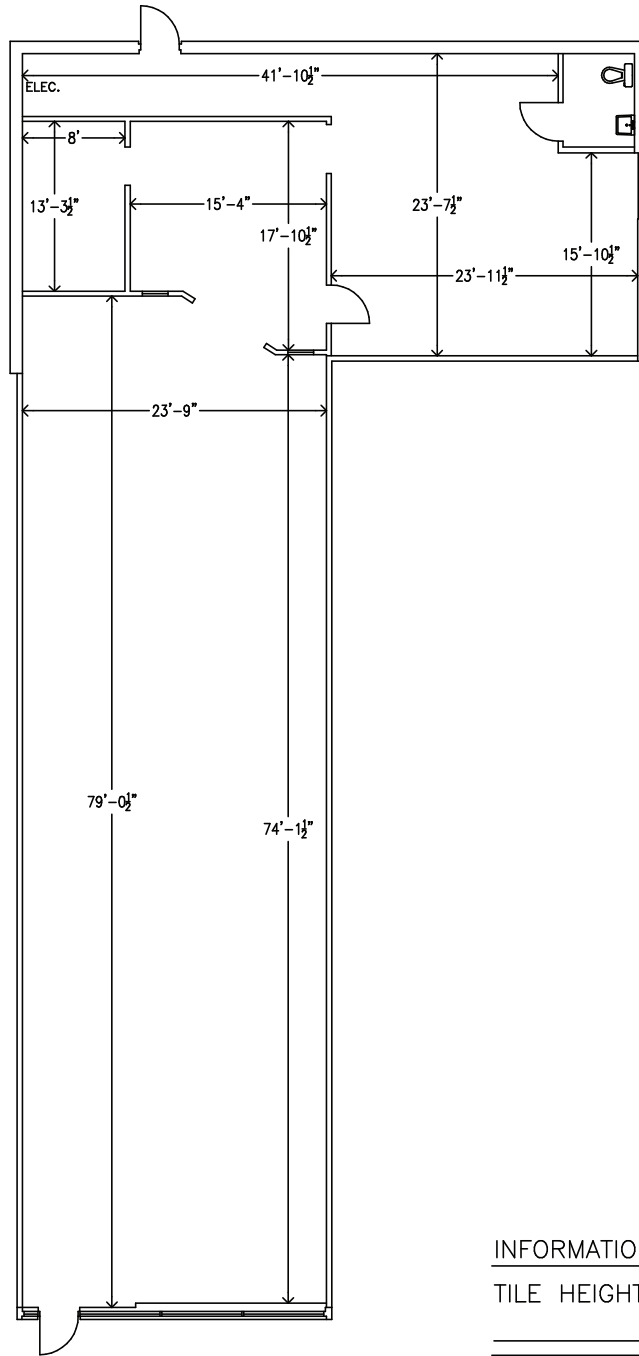

INFORMATION: _____
TILE HEIGHT: 10'7"

TOTAL RENTABLE: 3,056 SQ.FT.

TRADE AREA MAP

225 FAIRVIEW DRIVE

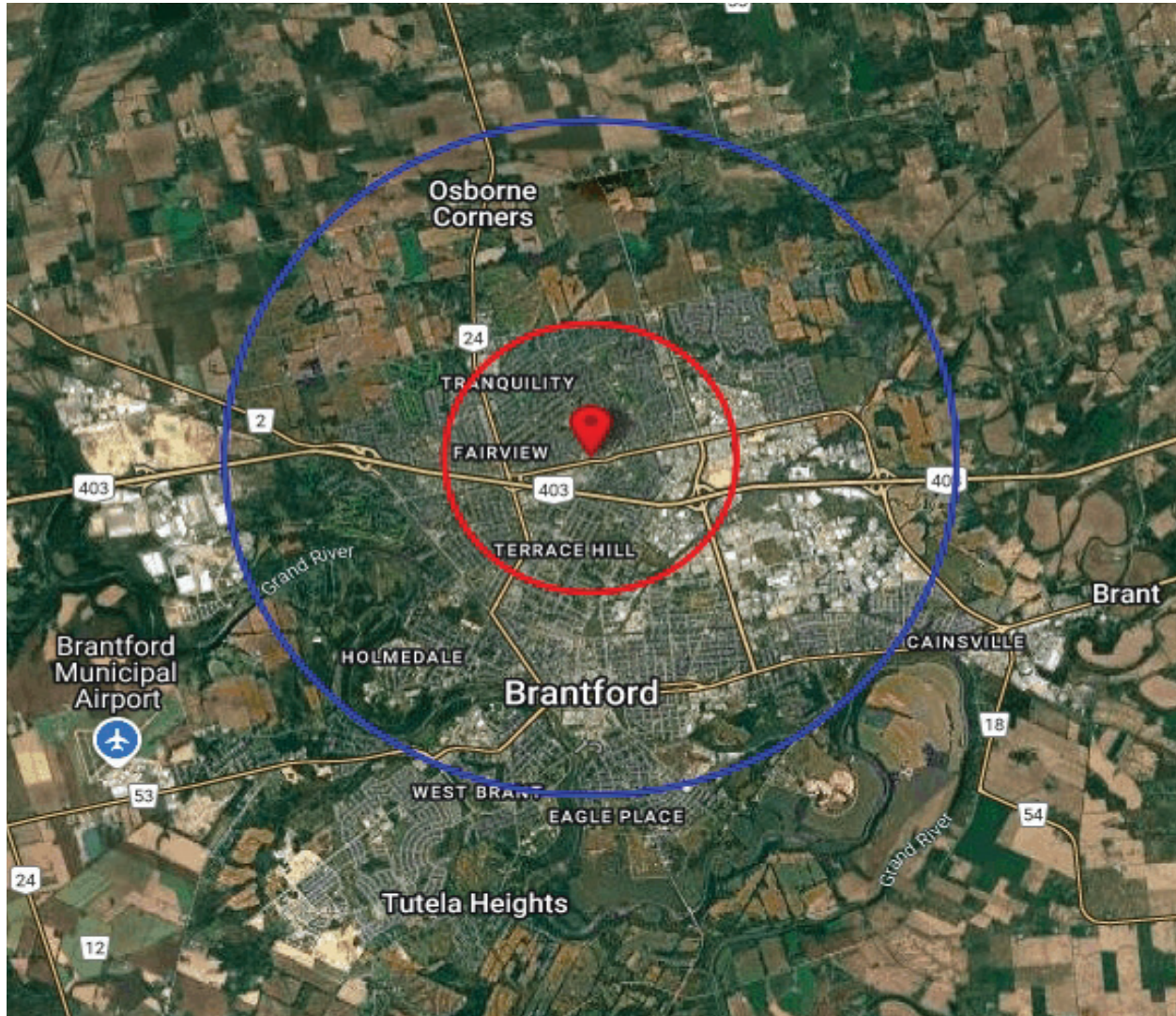

2024 Daytime Population	225 Fairview Dr, Brantford, ON N3R 7E3 0 - 2 km		225 Fairview Dr, Brantford, ON N3R 7E3 0 - 5 km	
		%		%
Total Estimated Population	28,315		88,961	
Total Daytime Population	26,917		91,268	
Daytime Population at Home	14,565	54.1%	45,825	50.2%
0 to 14 years	4,163	15.5%	13,478	14.8%
15 to 64 years	4,351	16.2%	17,083	18.7%
65 years and over	6,051	22.5%	15,263	16.7%
Daytime Population at Work	12,404	46.1%	45,536	49.9%
Work At Usual Place	8,147	30.3%	31,076	34.0%
Work Mobile	1,912	7.1%	6,996	7.7%
Work At Home	2,346	8.7%	7,465	8.2%

TRADE AREA DEMOGRAPHICS

225 FAIRVIEW DRIVE

2024 Demographic Snapshot	225 Fairview Dr, Brantford, ON N3R 7E3 0 - 2 km		225 Fairview Dr, Brantford, ON N3R 7E3 0 - 5 km	
		%		%
Total Population				
2019 estimated	27,411		84,668	
2024 estimated	28,315		88,961	
2029 Projected	29,511		94,397	
% Pop. Change (2019-2024)	3.3%		5.1%	
% Pop. Change (2024-2029)	4.2%		6.1%	
2024 Total Population by Age	28,315		88,961	
0 to 4 years	1,260	4.5%	4,408	5.0%
5 to 19 years	4,433	15.7%	13,727	15.4%
20 to 24 years	1,606	5.7%	5,643	6.3%
25 to 34 years	3,635	12.8%	13,957	15.7%
35 to 44 years	3,449	12.2%	11,343	12.8%
45 to 54 years	3,105	11.0%	9,917	11.1%
55 to 64 years	3,807	13.4%	11,791	13.3%
65 to 74 years	3,616	12.8%	10,302	11.6%
75 years & over	3,404	12%	7,873	9%
Median Age	44.4		40.8	
2024 Total Census Families	7,826		23,851	
Average Persons Per Family	3.0		2.9	
Total Couples	6,335	80.9%	18,554	77.8%
Without children at home	3,170	40.5%	9,305	39.0%
With children at home	3,165	40.4%	9,249	38.8%
Lone-parent families	1,491	19.1%	5,297	22.2%
Children Per Census Family	1.0		1.1	
2024 Educational Attainment (15 years+)	23,653		74,449	
Less than a bachelor degree	19,513	82.5%	62,035	83.3%
Bachelor degree & higher	4,139	17.5%	12,414	16.7%
2024 Households	11,339		37,076	
Persons per household	2.45		2.37	
Average household income	\$ 110,104		\$ 100,818	
2024 Occupied Dwellings	11,339		37,076	
Owned dwellings	8,105	71.5%	23,320	62.9%
Rented dwellings	3,234	28.5%	13,756	37.1%
Dominant building type	Houses		Houses	
Dominant period of construction	1961-1980		Before 1960	

TRADE AREA DEMOGRAPHICS

225 FAIRVIEW DRIVE

2024 Estimates Visible Minority	225 Fairview Dr, Brantford, ON N3R 7E3 0 - 2 km		225 Fairview Dr, Brantford, ON N3R 7E3 0 - 5 km	
		%		%
2024 Household Population by visible minority groups	27,796	%base	87,991	%base
Total visible minority population	2,848	10.2%	11,651	13.2%
Chinese	123	0.4%	494	0.6%
South Asian	573	2.1%	3,740	4.3%
Black	779	2.8%	3,008	3.4%
Filipino	266	1.0%	1,165	1.3%
Latin American	235	0.8%	779	0.9%
Southeast Asian	478	1.7%	1,127	1.3%
Arab	240	0.9%	535	0.6%
West Asian	31	0.1%	45	0.1%
Korean	0	0.0%	157	0.2%
Japanese	19	0.1%	30	0.0%
Visible minority, n.i.e.	56	0.2%	186	0.2%
Multiple visible minorities	48	0.2%	384	0.4%
Not a visible minority	24,948	89.8%	76,339	86.8%

2027 Projections Visible Minority	225 Fairview Dr, Brantford, ON N3R 7E3 0 - 2 km		225 Fairview Dr, Brantford, ON N3R 7E3 0 - 5 km	
		%		%
2027 Household Population by visible minority groups	28,361	%base	90,938	%base
Total visible minority population	3,179	11.2%	13,305	14.6%
Chinese	133	0.5%	536	0.6%
South Asian	676	2.4%	4,504	5.0%
Black	875	3.1%	3,414	3.8%
Filipino	291	1.0%	1,271	1.4%
Latin American	267	0.9%	914	1.0%
Southeast Asian	507	1.8%	1,206	1.3%
Arab	267	0.9%	596	0.7%
West Asian	37	0.1%	55	0.1%
Korean	0	0.0%	182	0.2%
Japanese	19	0.1%	30	0.0%
Visible minority, n.i.e.	57	0.2%	189	0.2%
Multiple visible minorities	49	0.2%	408	0.4%
Not a visible minority	25,182	88.8%	77,634	85.4%