

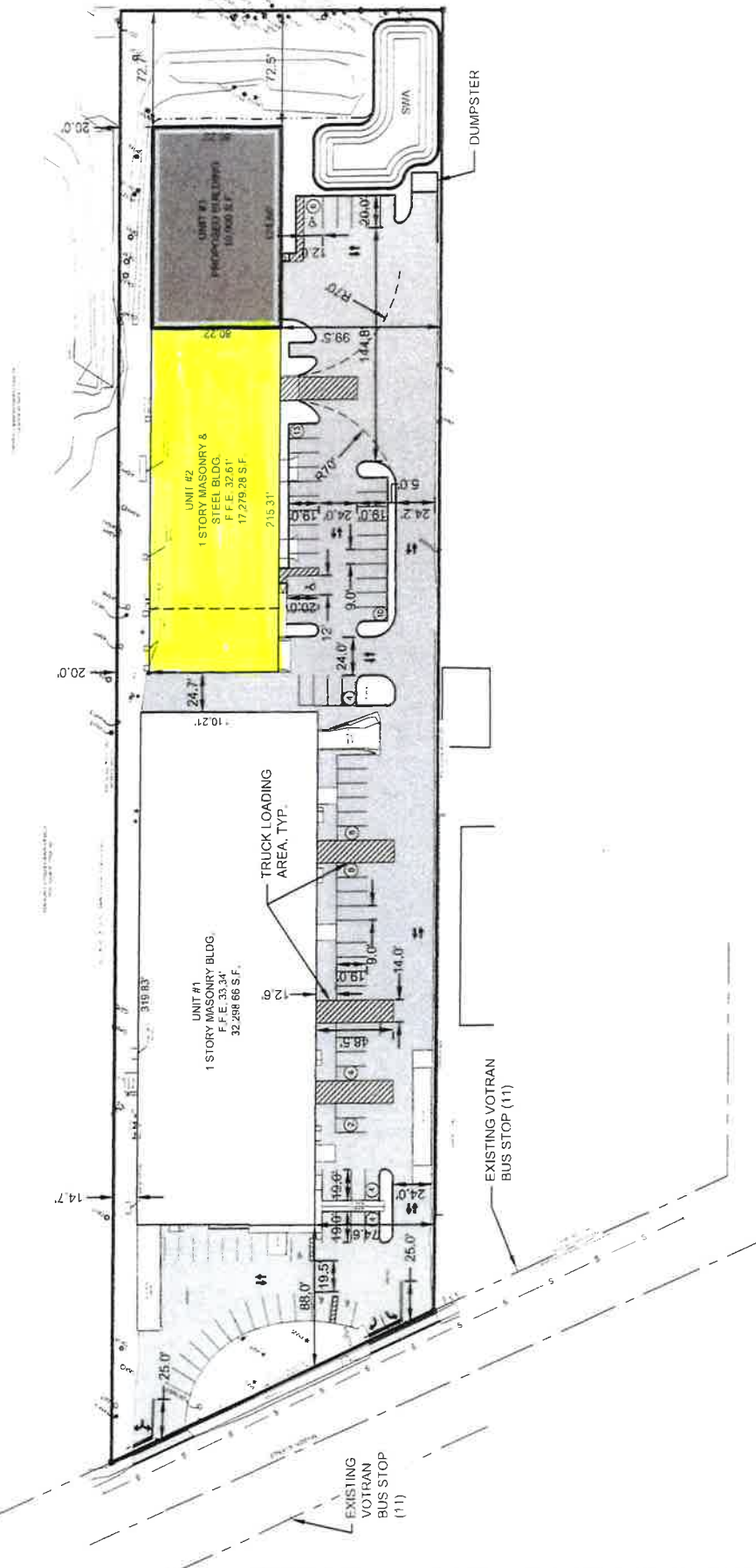

SCALE: 1" = 100'



DEV2022-158

SHEET 4 OF 5

NO.	DATE	REVISION
1	10/24/22	REVISED PER COOB COMMENTS DATED 9/9/22

EXHIBIT B - OVERALL DEVELOPMENT PLAN	
PROJECT: 888 MASON AVE COMMERCIAL PARK	SCALE: 1"=100'
FILE: 888-MASON PD EXHIBIT	DATE: 7/25/22; 10/24/22; 4/26/23

THE PERFORMANCE GROUP
CIVIL ENGINEERING / PLANNING / DEVELOPMENT



JOSEPH H. HOPKINS, P.E. NO. 48059
100 MARINA POINT DR. DAYTONA BEACH, FL 32114
TELEPHONE (386) 239-7466 FAX (386) 239-7120

- Table
- Ladder
- Rack
- Cooler/Fridge
- Water
- Loose Pallets

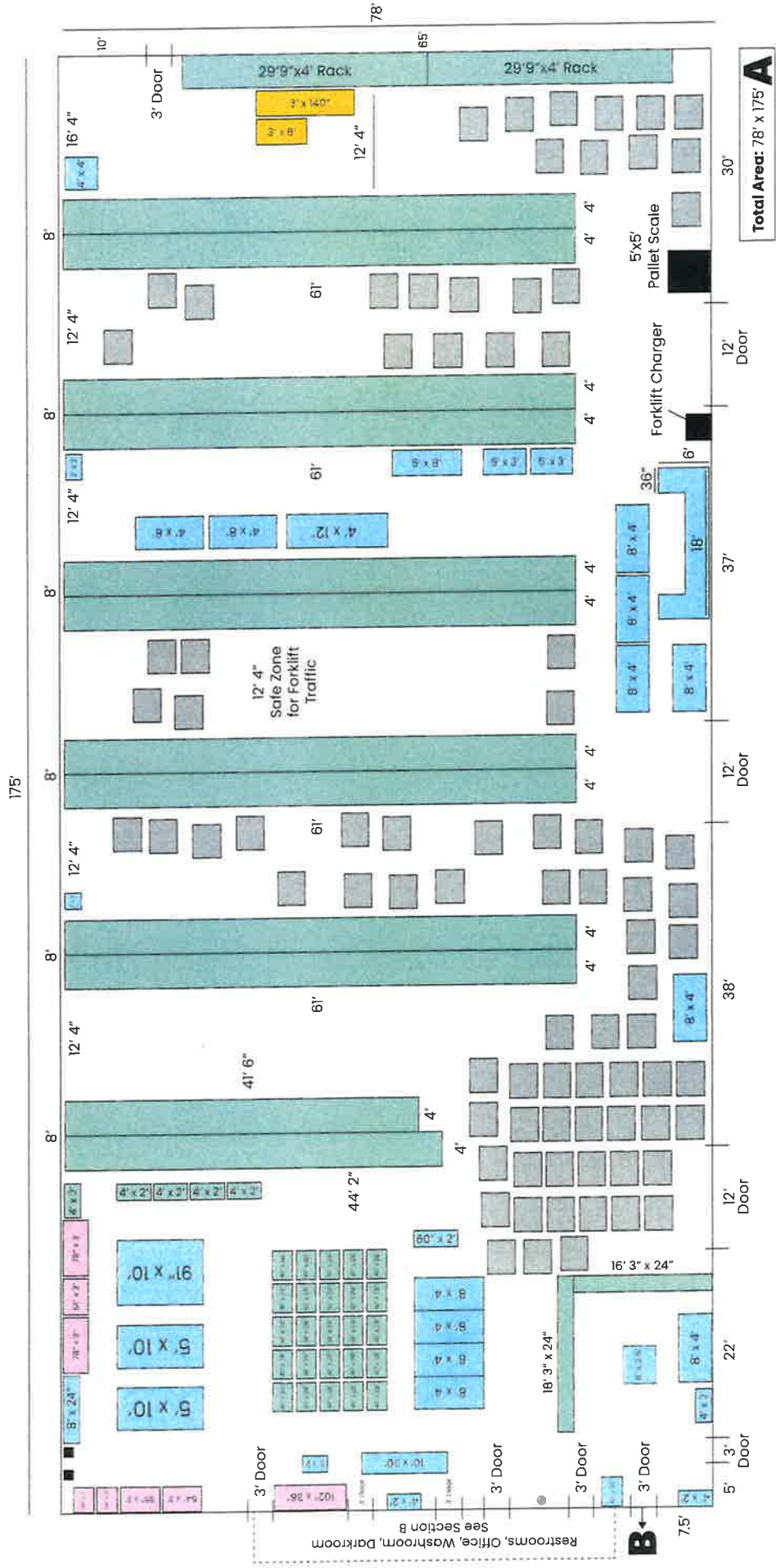

1 inch = 12 feet



-  Table
-  Cooler/Fridge
-  Water



28.5'

35'

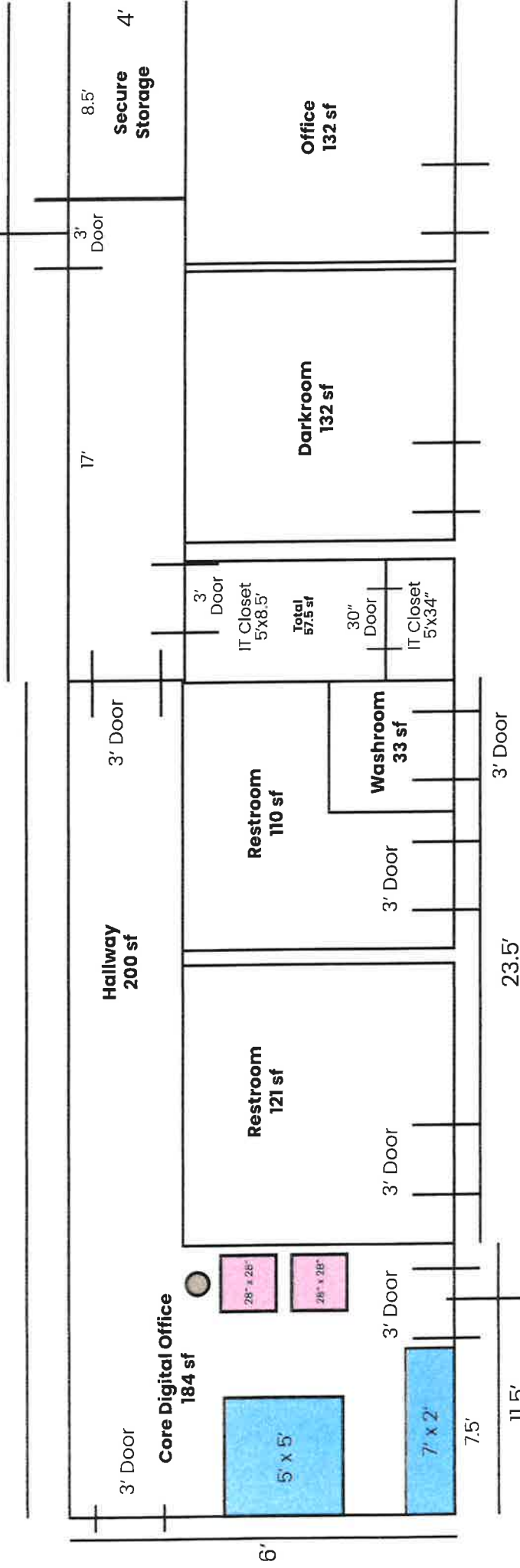

Downstairs Hall/Offices - Front B

1 inch = 4 feet

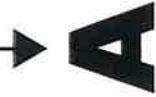

23.5'

3' Door

11.5'

7' x 2'

3' Door

3' Door

Washroom
33 sf

Restroom
121 sf

Restroom
110 sf

Total
57.5 sf

Darkroom
132 sf

Office
132 sf

Hallway
200 sf

3' Door

3' Door

Secure
Storage
4'

17'

8.5'

3' Door

Core Digital Office
184 sf

5' x 5'

28' x 28'

28' x 28'

3' Door

3' Door

IT Closet
5'x8.5'

IT Closet
5'x3.4"

30" Door

6'

1 inch = 4 feet



Upstairs Office **D**

