



**FOR LEASE**

*Small Office Space Available*  
**1080 Laskin Road**  
Virginia Beach, VA



**Ricky Anderson**

Executive Vice President  
+1 757 217 1892  
[ricky.anderson@colliers.com](mailto:ricky.anderson@colliers.com)

150 West Main Street  
Suite 1100  
Norfolk, VA 23510  
P: +1 757 490 3300

# Features

- ± 6,000 SF two-story office building
- Available Space:  
Suite 103: ± 650 SF available
- Monument signage available
- Close to Birdneck Road/Laskin Road intersection with easy access to I-264
- Close proximity to Sentara Virginia Beach General Hospital, Hilltop Shopping Center, and the Virginia Beach Oceanfront
- Lease Rate: \$1,400 per month (net of electric and janitorial)

## Floor Plan

Suite 103  
± 650 SF available

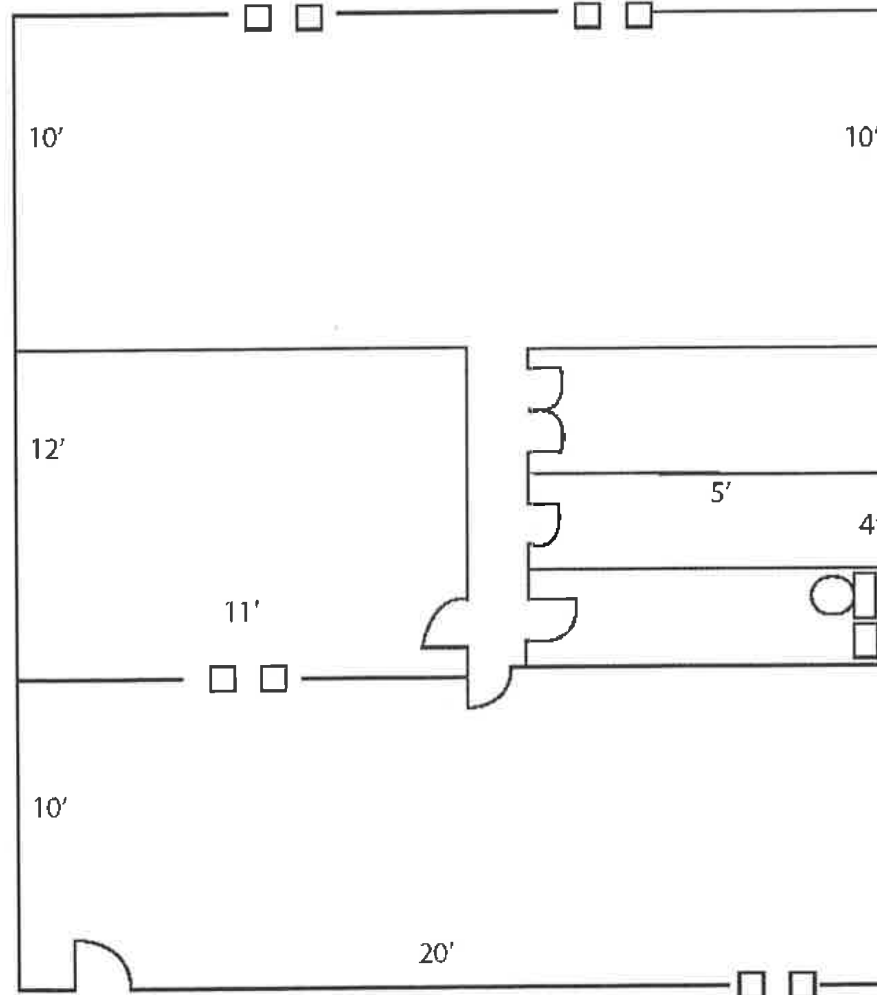



**Ricky Anderson**

Executive Vice President

+1 757 217 1892

[ricky.anderson@colliers.com](mailto:ricky.anderson@colliers.com)

150 West Main Street  
 Suite 1100  
 Norfolk, VA 23510  
 P: +1 757 490 3300



This document has been prepared by Colliers International for advertising and general information only. Colliers International makes no guarantees, representations or warranties of any kind, expressed or implied, regarding the information including, but not limited to, warranties of content, accuracy and reliability. Any interested party should undertake their own inquiries as to the accuracy of the information. Colliers International excludes unequivocally all inferred or implied terms, conditions and warranties arising out of this document and excludes all liability for loss and damages arising there from. This publication is the copyrighted property of Colliers International and/or its licensor(s). ©2026. All rights reserved.