

# RAMAPO PLAZA

1,860 SF - 5,220 SF AVAILABLE

755-797 HAMBURG TPKE.  
WAYNE, NJ



**CATALYST**  
REAL ESTATE PARTNERS

FOR MORE  
INFORMATION

WILLIAM FARKAS  
MIKE TESTA

bf@catalystrenj.com C: 973.223.6600  
mt@catalystrenj.com C: 201.232.6086

All information is from sources deemed reliable and is submitted subject to errors, omissions, change of price, terms, prior sales and withdrawals.

CATALYST REAL ESTATE PARTNERS | 20 White St. Unit 2A, Red Bank, NJ, 07701 | 732.333.8571 | info@catalystrenj.com

**1,860 SF - 10,215 SF  
AVAILABLE**

755-797 HAMBURG TPKE.  
WAYNE, NJ

# RAMAPO PLAZA



**GLA:** 57,963 SF  
**LOT:** +/- 9.29 ACRES  
**AVAILABLE:** UP TO 5,220 SF INLINE  
**PARKING:** 455 SPACES  
**TRAFFIC:** 24,430 VPD HAMBURG  
 22,693 VPD VALLEY  
**RENT:** CALL FOR QUOTE  
**NNN:** EST. \$11.01 PSF  
 CAM: \$5.46  
 INS: \$0.54  
 TAX: \$5.01

TRAFFIC CONTROLLED  
INTERSECTION IN HIGH VOLUME RETAIL  
MARKET



	1 MILE	3 MILE	5 MILE
POPULATION	10,392	78,955	320,242
AVG. HOUSEHOLD INCOME	\$164,117	\$190,518	\$146,272
HOUSEHOLDS	4,475	27,040	110,285
DAYTIME POPULATION	7,149	49,299	206,914
NUMBER OF EMPLOYEES	4,413	28,392	119,164
AVERAGE HOUSEHOLD SIZE	2.3	2.8	2.9

**FOR MORE  
INFORMATION**

**WILLIAM FARKAS** bf@catalystrenj.com C: 973.223.6600  
**MIKE TESTA** mt@catalystrenj.com C: 201.232.6086

All information is from sources deemed reliable and is submitted subject to errors, omissions, change of price, terms, prior sales and withdrawals.

[www.CATALYSTRENJ.com](http://www.CATALYSTRENJ.com)



**1,860 SF - 5,220 SF  
AVAILABLE**

755-797 HAMBURG TPKE.  
WAYNE, NJ

# RAMAPO PLAZA

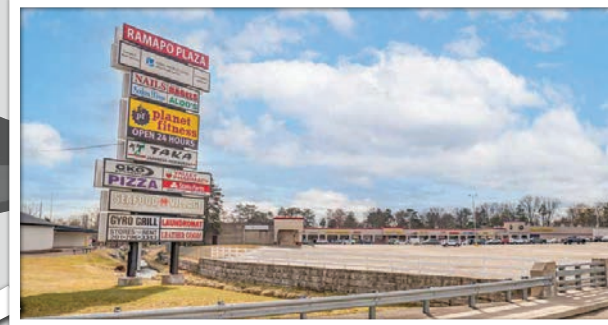

## TENANT ROSTER

- 759. Valley Health
- 761-765. Pre-Leasing 3,360 SF
- 767. Pre-Leasing 1,860 SF
- 769. Laundromat
- 771. AVAILABLE 3,720 SF
- 775. Marty's Burgers
- 781. Pre-Leasing 5,100 SF
- 783. Gyro Grill
- 785. Juice Bar
- 787. Taka Japanese
- 789. State Farm
- 791. Valley Pharmacy
- 783. Lucky Nails
- 795. Victor Salon
- 797. Planet Fitness



**FOR MORE  
INFORMATION**

**WILLIAM FARKAS** bf@catalystrenj.com C: 973.223.6600  
**MIKE TESTA** mt@catalystrenj.com C: 201.232.6086

All information is from sources deemed reliable and is submitted subject to errors, omissions, change of price, terms, prior sales and withdrawals.

[www.CATALYSTRENJ.com](http://www.CATALYSTRENJ.com)



**1,860 SF - 5,220 SF  
AVAILABLE**

755-797 HAMBURG TPKE.  
WAYNE, NJ

# RAMAPO PLAZA

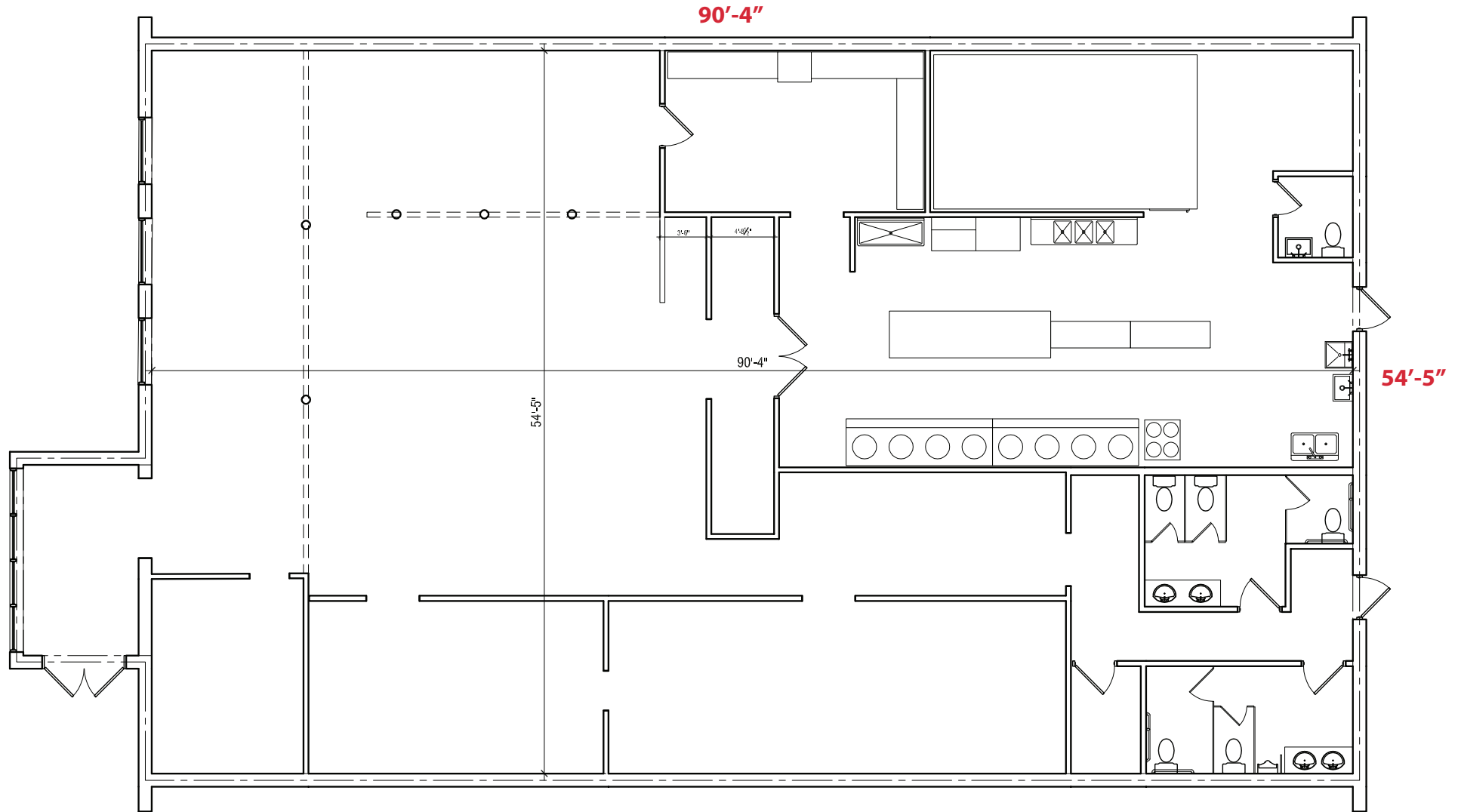

1 FLOOR PLAN - 781  
1/4" = 1'-0"

**AREA CALCULATIONS :**  
SQ.FT.: 5,210

**FOR MORE  
INFORMATION**

**WILLIAM FARKAS** bf@catalystrenj.com C: 973.223.6600  
**MIKE TESTA** mt@catalystrenj.com C: 201.232.6086

All information is from sources deemed reliable and is submitted subject to errors, omissions, change of price, terms, prior sales and withdrawals.

[www.CATALYSTRENJ.com](http://www.CATALYSTRENJ.com)



**1,860 SF - 5,220 SF  
AVAILABLE**

755-797 HAMBURG TPKE.  
WAYNE, NJ

# RAMAPO PLAZA

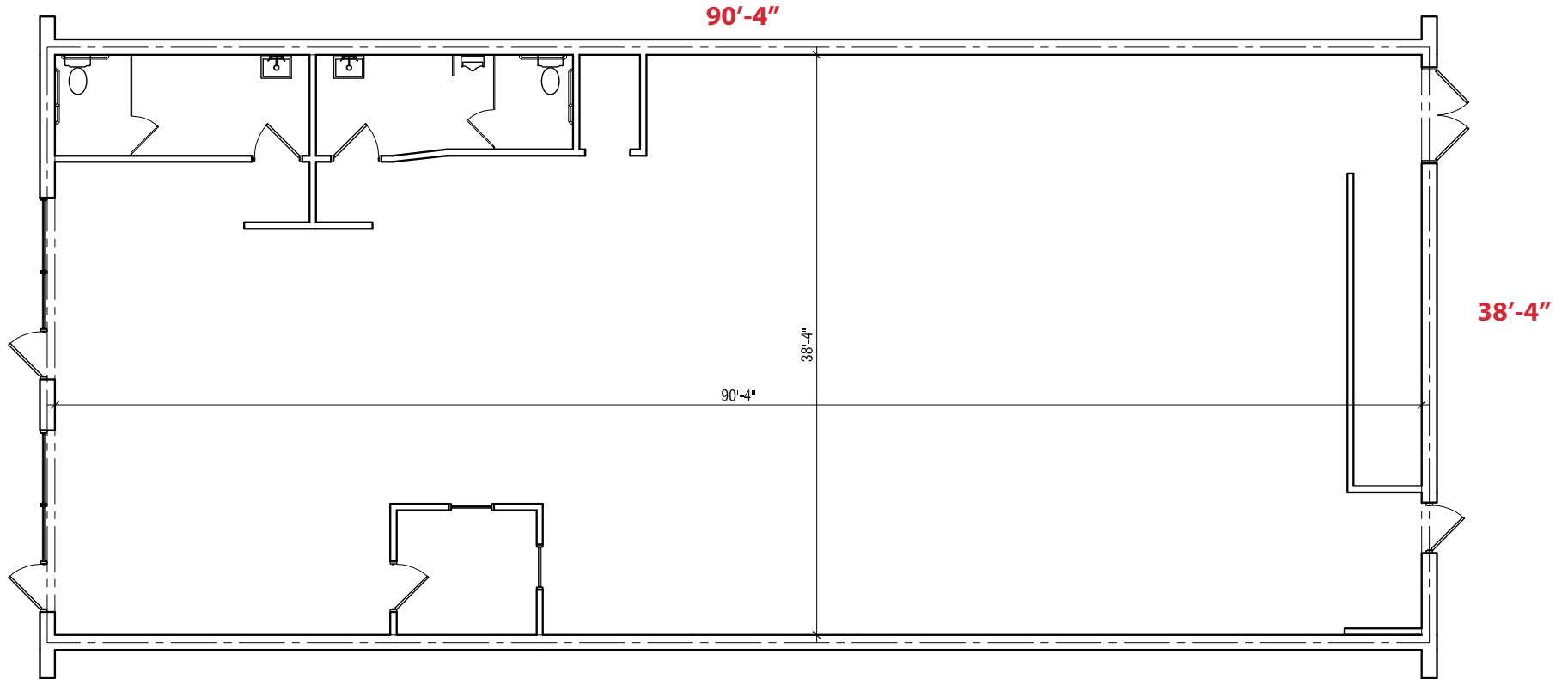

1 FLOOR PLAN - 771  
1/4" = 1'-0"

**AREA CALCULATIONS :**

SQ.FT.: 3,592.6

**FOR MORE  
INFORMATION**

**WILLIAM FARKAS** bf@catalystrenj.com C: 973.223.6600  
**MIKE TESTA** mt@catalystrenj.com C: 201.232.6086

All information is from sources deemed reliable and is submitted subject to errors, omissions, change of price, terms, prior sales and withdrawals.

[www.CATALYSTRENJ.com](http://www.CATALYSTRENJ.com)



**1,860 SF - 5,220 SF  
AVAILABLE**

755-797 HAMBURG TPKE.  
WAYNE, NJ

# RAMAPO PLAZA

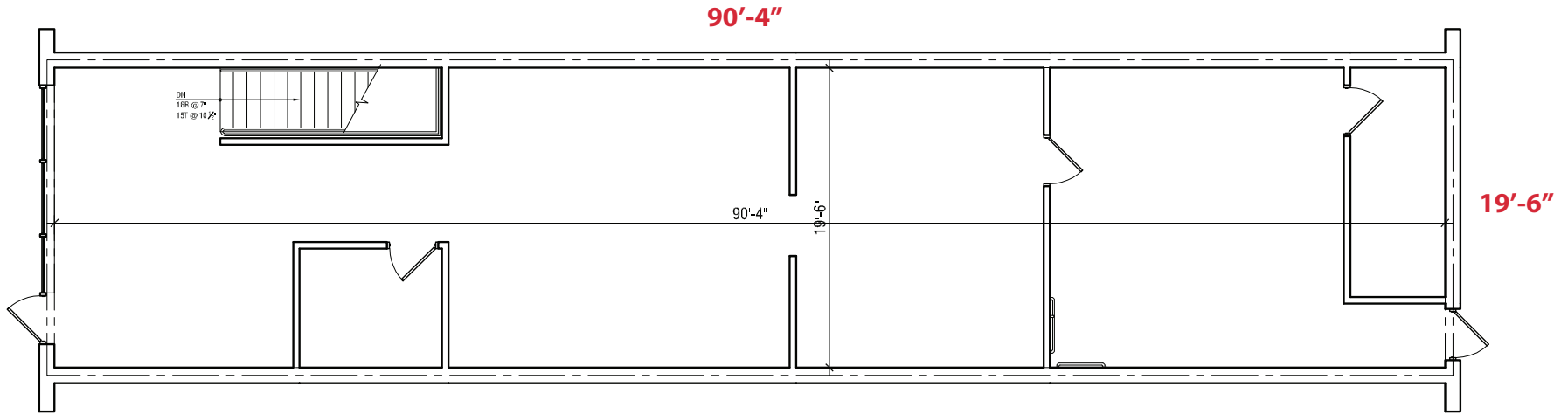

**1 FLOOR PLAN - 767** **AREA CALCULATIONS :**  
1/8" = 1'-0" .SQ.FT.: 1,872

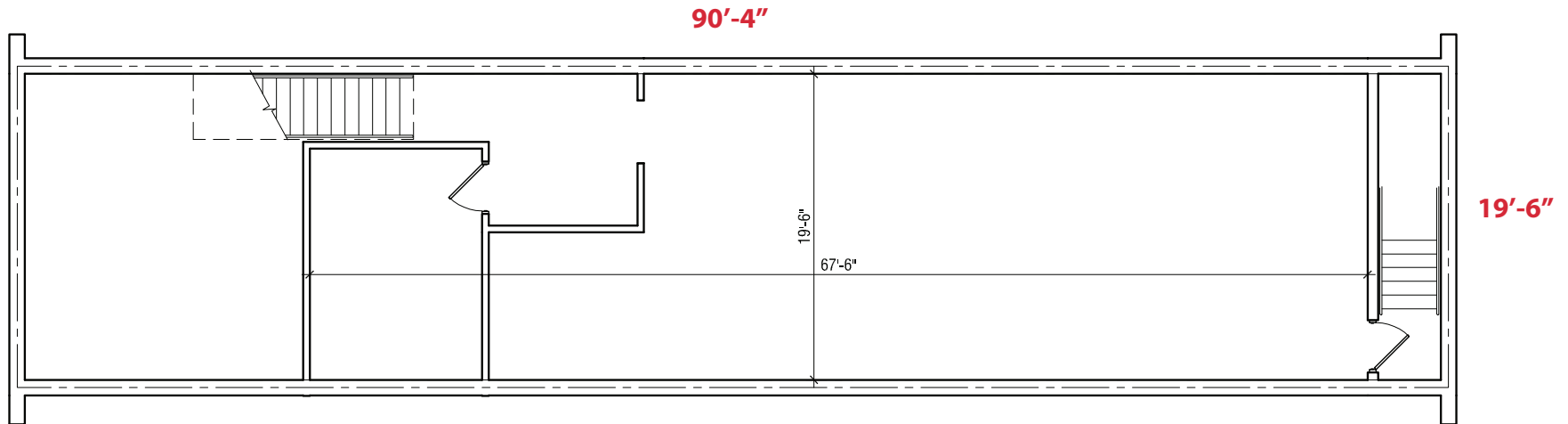

**2 BASEMENT PLAN - 767** **AREA CALCULATIONS :**  
1/8" = 1'-0" GROSS SQ.FT.: 1,872

**FOR MORE INFORMATION** | **WILLIAM FARKAS** bf@catalystrenj.com C: 973.223.6600  
**MIKE TESTA** mt@catalystrenj.com C: 201.232.6086

All information is from sources deemed reliable and is submitted subject to errors, omissions, change of price, terms, prior sales and withdrawals.

[www.CATALYSTRENJ.com](http://www.CATALYSTRENJ.com)



**1,860 SF - 5,220 SF  
AVAILABLE**

755-797 HAMBURG TPKE.  
WAYNE, NJ

# RAMAPO PLAZA

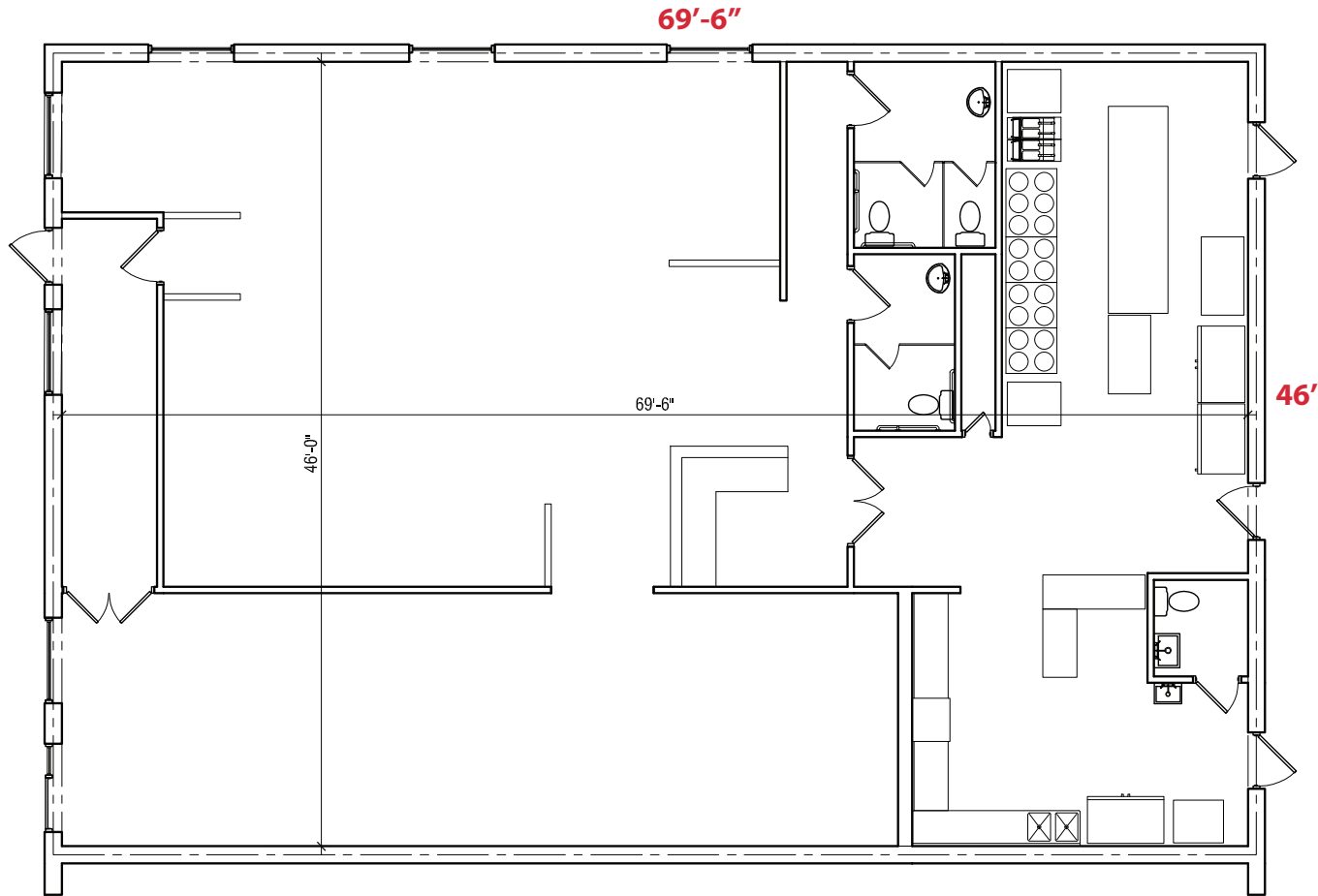

1 FLOOR PLAN - 771  
1/8" = 1'-0"

AREA CALCULATIONS :  
SQ.FT.: 3,313.5

**FOR MORE  
INFORMATION**

**WILLIAM FARKAS** bf@catalystrenj.com C: 973.223.6600  
**MIKE TESTA** mt@catalystrenj.com C: 201.232.6086

All information is from sources deemed reliable and is submitted subject to errors, omissions, change of price, terms, prior sales and withdrawals.

[www.CATALYSTRENJ.com](http://www.CATALYSTRENJ.com)



**1,860 SF - 5,220 SF  
AVAILABLE**

755-797 HAMBURG TPKE.  
WAYNE, NJ

# RAMAPO PLAZA

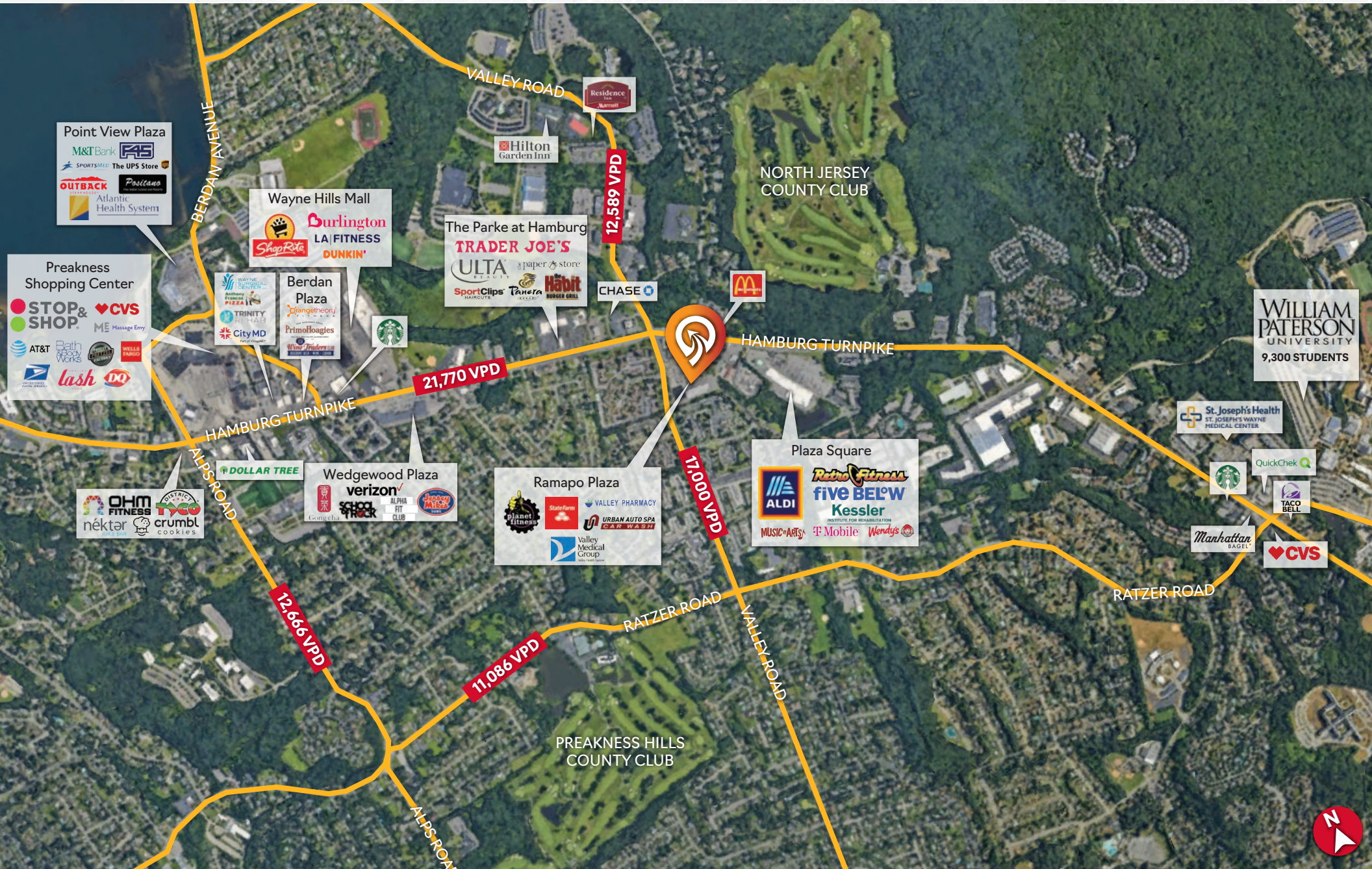

**FOR MORE  
INFORMATION**

**WILLIAM FARKAS** bf@catalystrenj.com C: 973.223.6600  
**MIKE TESTA** mt@catalystrenj.com C: 201.232.6086

All information is from sources deemed reliable and is submitted subject to errors, omissions, change of price, terms, prior sales and withdrawals.

[www.CATALYSTRENJ.com](http://www.CATALYSTRENJ.com)

