



INDUSTRIAL SPACE FOR LEASE

14910-14930 BOGLE DRIVE

CHANTILLY, VA 20151



SITE PLAN

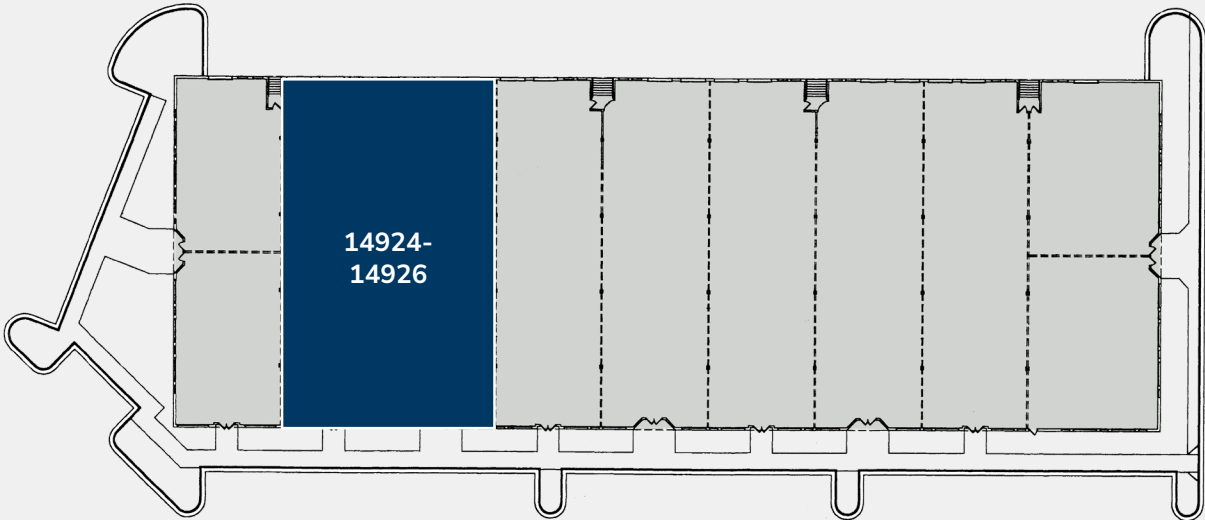

SPECS

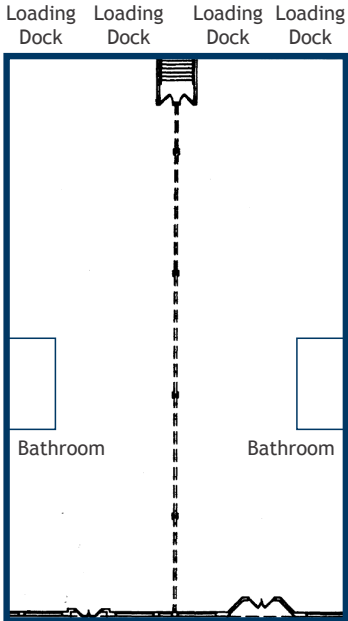

Suite	14924-14926
Available SF	5,200 - 10,400 SF
Clear Height	18'
Loading	Four Loading Docks

AMENITIES MAP



REGIONAL MAP



LOCATION & TRAVEL TIMES

RT. 50	3 MINUTES (0.9 MI)	D.C.	30 MINUTES (26.6 MI)
RT. 28	4 MINUTES (1.3 MI)	DCA	35 MINUTES (30.3 MI)
I-66	7 MINUTES (4.3 MI)	BALTIMORE	1 HOUR 7 MIN (65 MI)
IAD	11 MINUTES (7.4 MI)	RICHMOND	1 HOUR 53 MIN (107 MI)

14910-14912

BOGLE DRIVE

ANDREW HASSETT

703.705.2921

andrew.hassett@streamrealty.com

CAULLEY DERINGER

703.705.2907

caulley.deringer@streamrealty.com

STEVE CLOUD

703.705.2918

steve.cloud@streamrealty.com



7900 Tysons One Place
Suite 280
McLean, VA 22102

Copyright © 2024 Stream Realty Partners, All rights reserved.

The information contained herein was obtained from sources believed reliable; however, Stream Realty Partners, L.P. make no guarantees, warranties, or representations as to the completeness or accuracy thereof. The presentation of this property is submitted subject to errors, change of price, or conditions, prior sale or lease, or withdrawal without notice.