

GRAB+GO OPPORTUNITY AT GRAND CENTRAL TERMINAL ON VANDERBILT AVENUE

CBRE



GRAND
CENTRAL®

RFP ISSUANCE:	APRIL 20 TH , 2026
WALKTHROUGH:	APRIL 29 TH , 2026
RFP DUE DATE:	MAY 20 TH , 2026

- White boxed - Move-in ready
- Grab and go space at the entrance of Grand Central

FLOOR PLAN | PC-01 | 95 SF

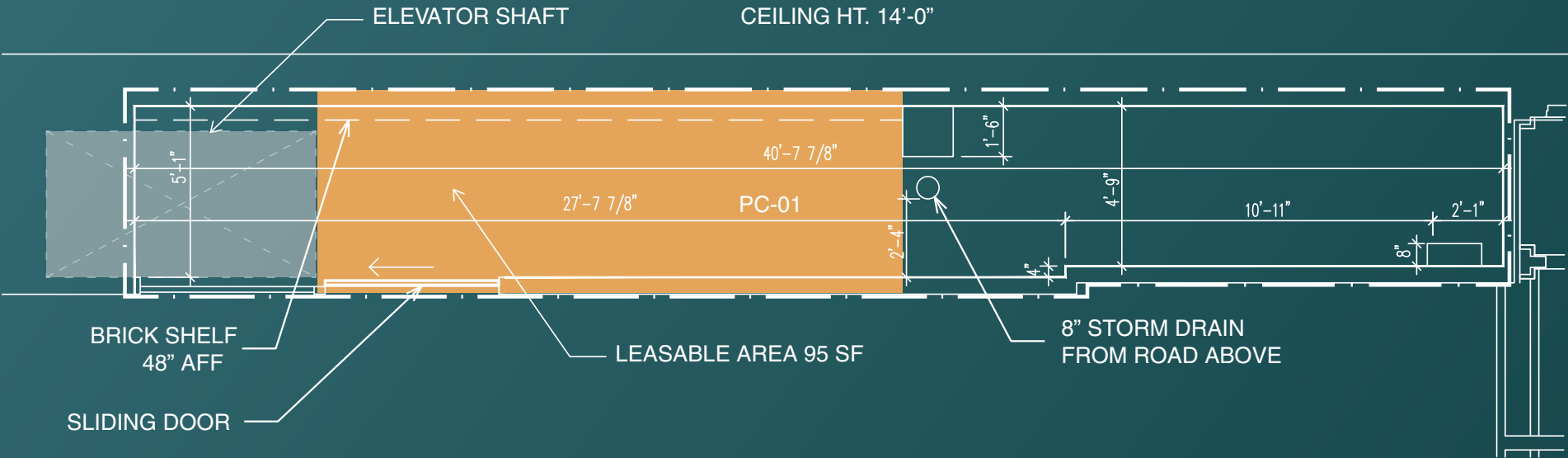

VANDERBILT

PROPOSED CONCEPT





GRAND CENTRAL®

RFP ISSUANCE: APRIL 20TH, 2026

WALKTHROUGH: APRIL 29TH, 2026

RFP DUE DATE: MAY 20TH, 2026

MATT CHMIELECKI

+1 212 984 6698

Matt.Chmielecki@cbre.com

PRESTON CANNON

+1 212 984 6544

Preston.Cannon@cbre.com

FRANCES ROYER

+1 212 895 0956

Frances.Royer@cbre.com

© 2026 CBRE, Inc. All rights reserved. This information has been obtained from sources believed reliable, but has not been verified for accuracy or completeness. You should conduct a careful, independent investigation of the property and verify all information. Any reliance on this information is solely at your own risk. CBRE and the CBRE logo are service marks of CBRE, Inc. All other marks displayed on this document are the property of their respective owners, and the use of such logos does not imply any affiliation with or endorsement of CBRE.

CBRE