



## **Modern Multi-Unit Two-Storey Commercial Space**

Ideal for office, showroom, studio, or live/work users

*Configurations from 1,448 SF to 8,992 SF*

### **Get more infomation**

**Jesse Fragale\***

Vice President, Leasing & Investment Sales  
+1 416 895 1422  
jesse.fragale@avisonyoung.com

**Jordan Morrison\***

Vice President  
+1 416 939 5593  
jordan.morrison@avisonyoung.com

**Sarah Ball\***

Associate  
+1 647 252 41563  
sarah.ball@avisonyoung.com

\*Sales Representative

### Opportunity

Brand-new two-storey unit offering a flexible layout ideal for office, showroom, or live/work use. The main floor features an open-concept design with polished concrete floors, a two-piece washroom, private outdoor space, and one on-site parking spot. A roughed-in kitchen allows for easy customization. The second level includes a three-piece bathroom and versatile space suitable for a bedroom, lounge, or additional workspace. Located in a transit-rich neighbourhood near subway lines, Bloor GO Station, and the UP Express, with cafes, green space, and amenities nearby. A modern, adaptable unit in a highly accessible location available for immediate occupancy.

### Property Details

**TOTAL AVAILABILITY**  
Up to 8,992 sf

**AVAILABLE**  
Immediate

**NET RENT**  
Contact listing agents

**ADDITIONAL RENT**  
\$11.45 psf

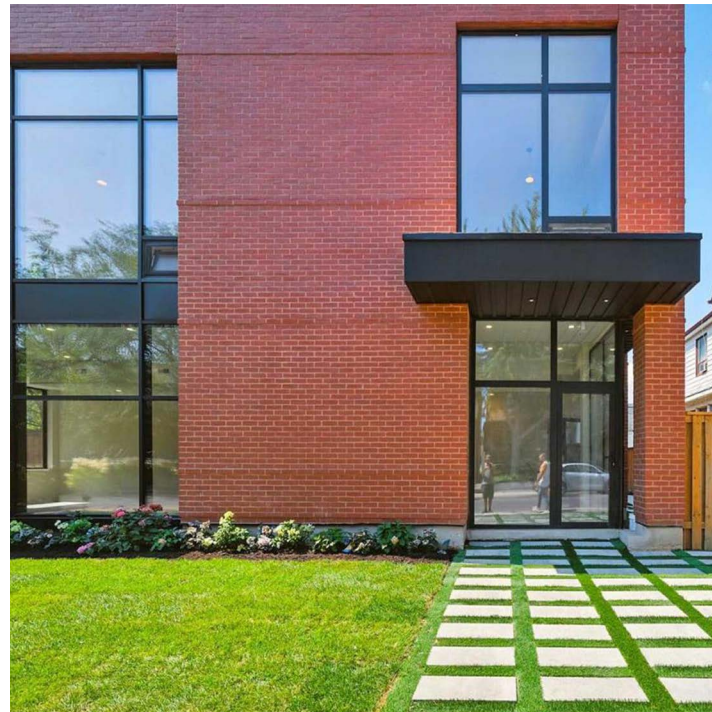

### Property Highlights



Parking spaces available



Abundance of natural light



Flexible floor plan



Transit-friendly location

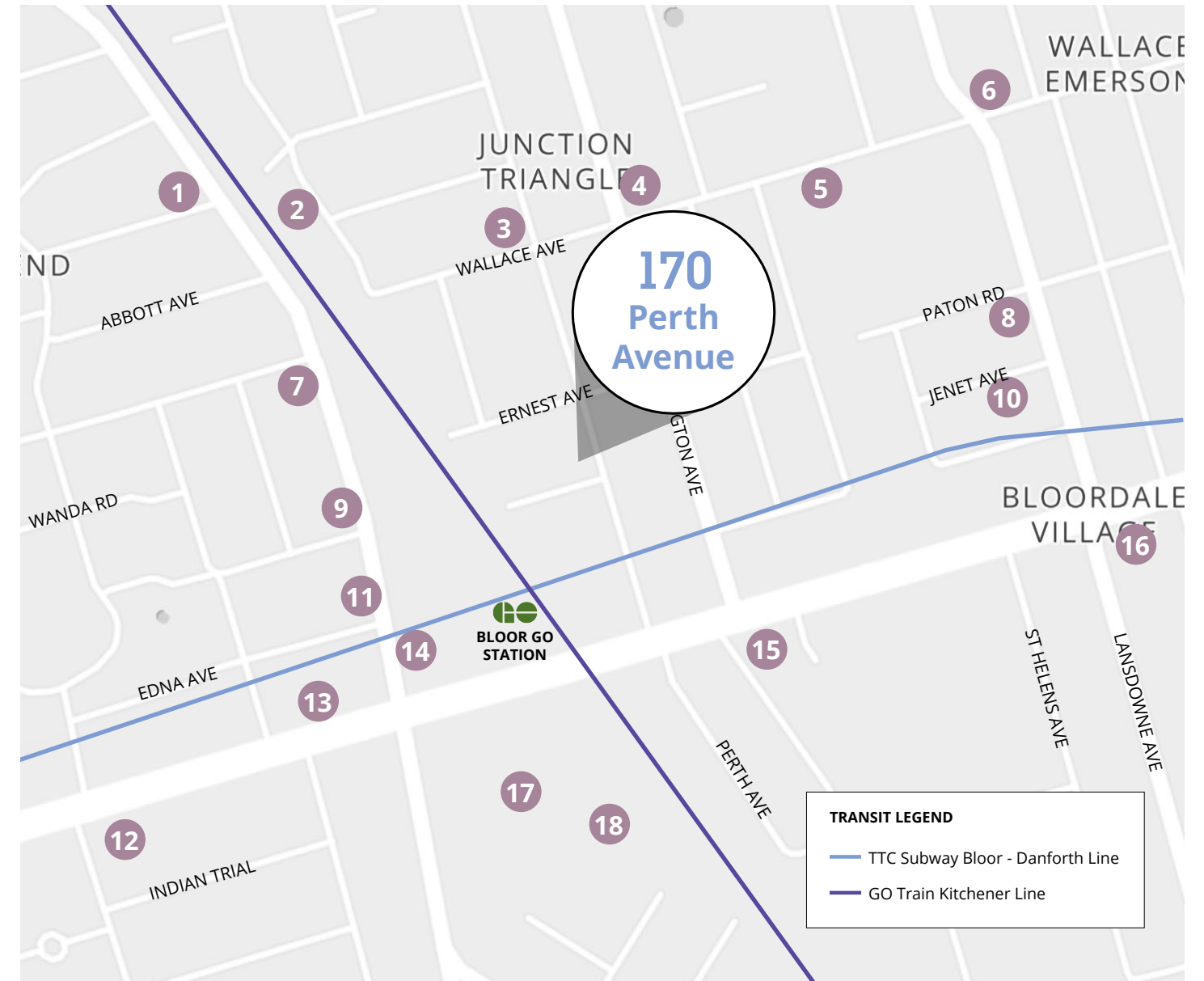

### Nearby amenities

- |                            |                    |                     |                |             |
|----------------------------|--------------------|---------------------|----------------|-------------|
| 1. Aisle 3                 | 4. Wallace Market  | 8. Balam Toronto    | 12. The Wicket | 16. Sugo    |
| 2. Okayok                  | 5. Halo Brewery    | 9. The Merseyside   | 13. Hoyra      | 17. LCBO    |
| 3. Lucky Convenience Store | 6. Hello Darling   | 10. Tavora Foods    | 14. Leni Poki  | 18. Loblaws |
|                            | 7. Phancy's Bodega | 11. Fantasy Kitchen | 15. Thai Nyyom |             |

### Drive times

**7 min**

Bloor GO Station

**23 min**

Union Station

**26 min**

UP Express and Pearson Airport

**28 min**

Eaton Centre

Floor Plans

1st floor

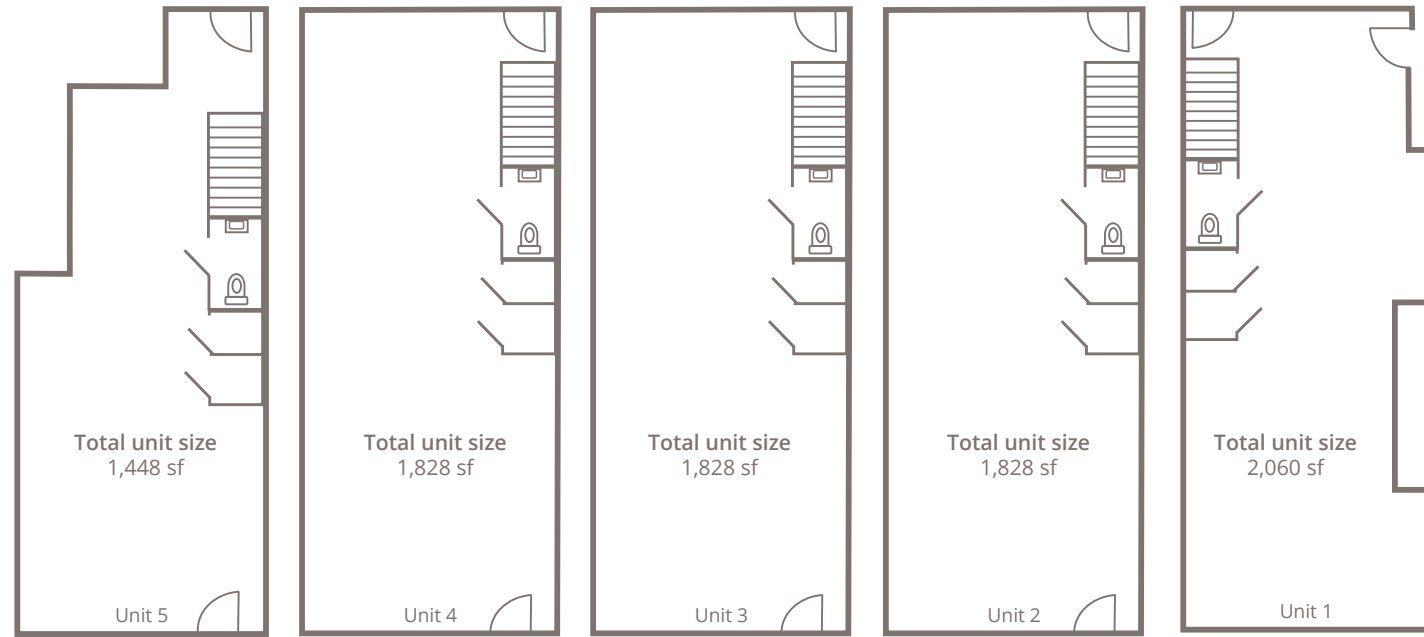

2nd floor

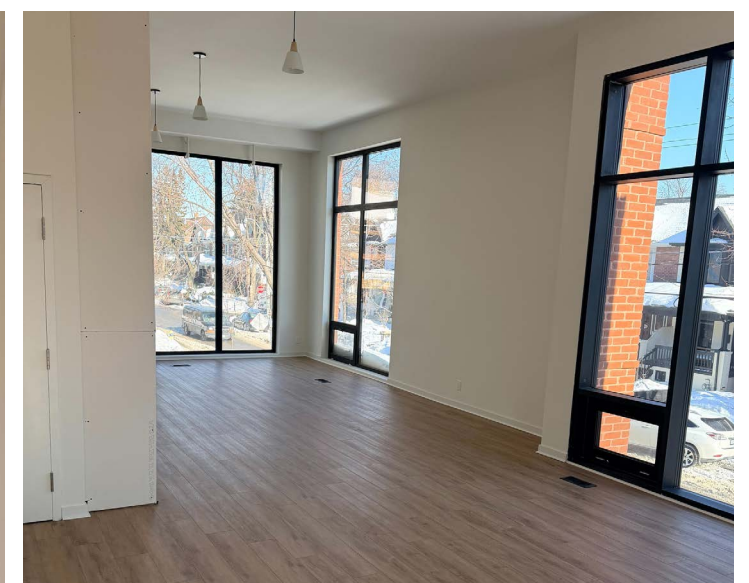
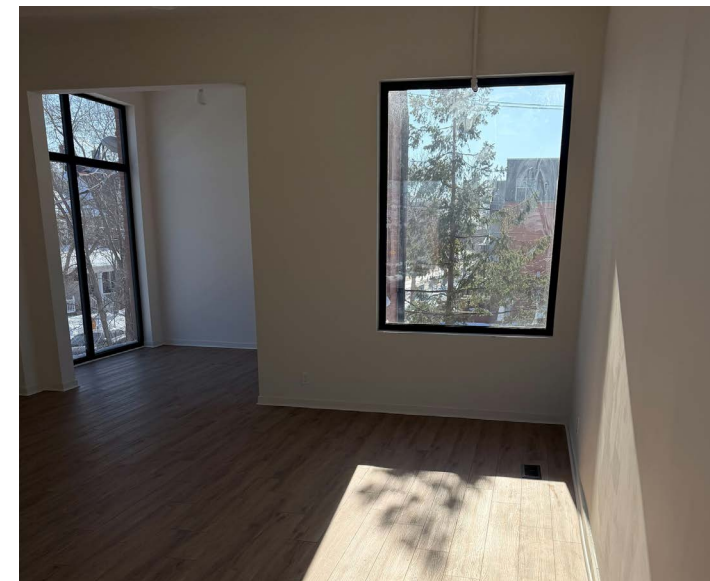
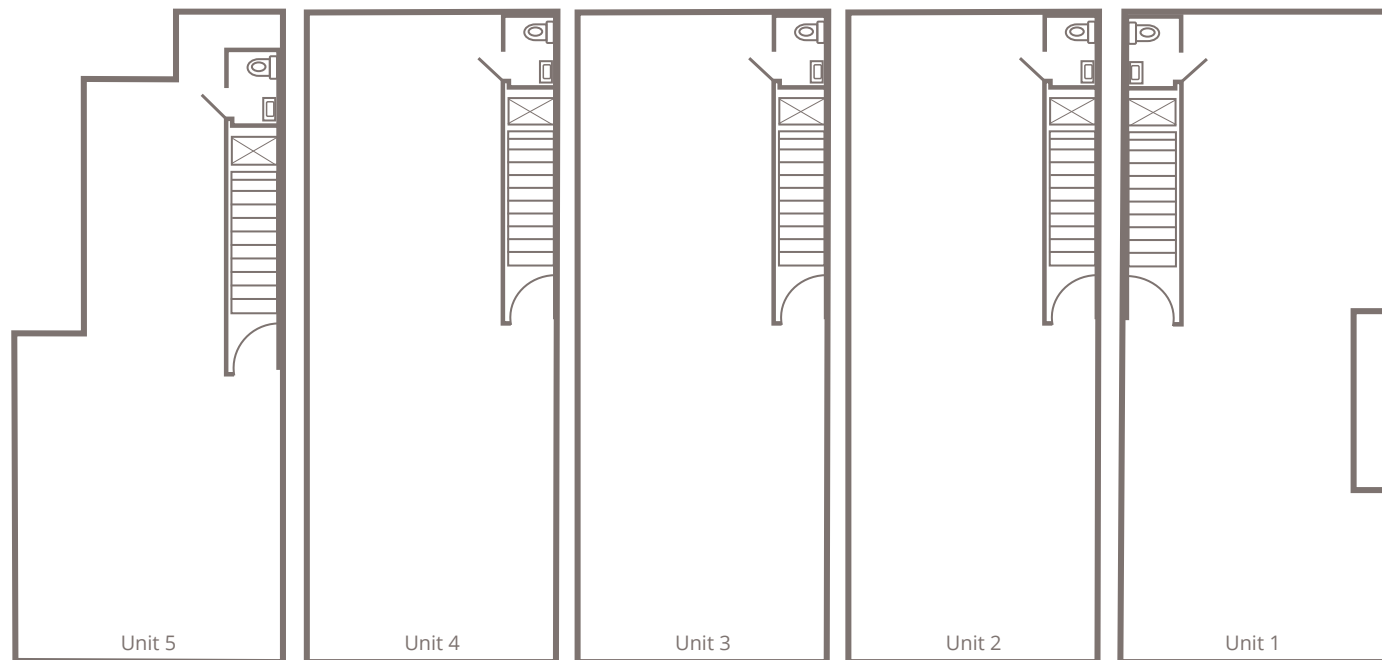

\*Images shown are of a selected unit and may not be representative of all units



## Contact for more information

**Jesse Fragale\***

Vice President, Leasing & Investment Sales  
+1 416 895 1422  
jesse.fragale@avisonyoung.com

**Sarah Ball\***

Associate  
+1 647 252 41563  
sarah.ball@avisonyoung.com

\*Sales Representative

**Jordan Morrison\***

Vice President  
+1 416 939 5593  
jordan.morrison@avisonyoung.com

2500-222 Bay Street  
Mailbox #245  
Toronto, ON M5K 1J5  
+1 416 955 0000

[avisonyoung.ca](http://avisonyoung.ca)

**AVISON  
YOUNG**



Platinum member