



FOR LEASE

Prime High-Visibility 2nd Generation Restaurant & Retail Opportunity

510 South Broadway
Los Angeles, CA 90013

Available Units

2

Floor

1st Floor

Available Units	Use	Rentable SF	Asking Rent
Unit 1	Restaurant	3,830 SF	\$5.00/SF/Mo. NNN
Unit 2	Retail	3,830 SF	\$3.00/SF/Mo. NNN

Property Type

Retail / Restaurant

Property Highlights

- Ground-floor space with excellent street frontage along South Broadway
- **Unit 1:** 2nd generation restaurant; former restaurant build-out that offers strong pedestrian exposure and branding visibility
- **Unit 2:** Current interiors delivered in a flexible shell condition
- Ideal for food & beverage operators seeking a faster path to market in the heart of Downtown Los Angeles

For information, please contact:

Brent Koo
Sr. Managing Director
t 213-503-0606
brent.koo@nmrk.com
CA RE Lic. #01915382

Lex Yoo
Sr. Managing Director
t 213-537-9691
lex.yoo@nmrk.com
CA RE Lic. #01879695

Nina Moon
Sr. Advisor
t 213-500-6462
ninamoon@gmail.com
CA RE Lic. #01815437

555 S. Flower St., Suite 3550
Los Angeles, CA 90071



nmrk.com

NEWMARK

EPIQUE
REALTY

Corporate License #01355491

The information contained herein has been obtained from sources deemed reliable but has not been verified and no guarantee, warranty or representation, either express or implied, is made with respect to such information. Terms of sale or lease and availability are subject to change or withdrawal without notice.

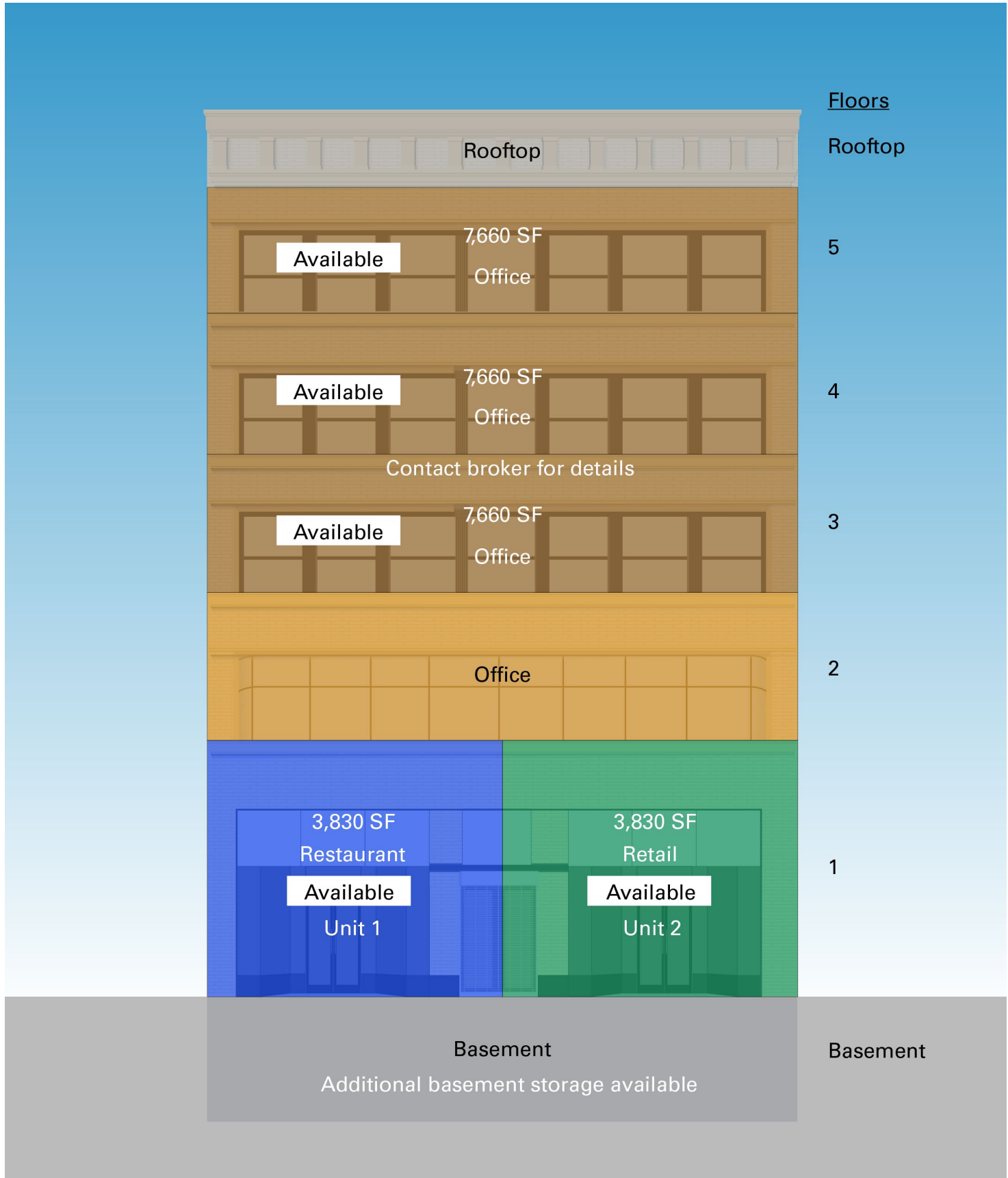

Unit 1 (Restaurant) Floor Plan & Photos

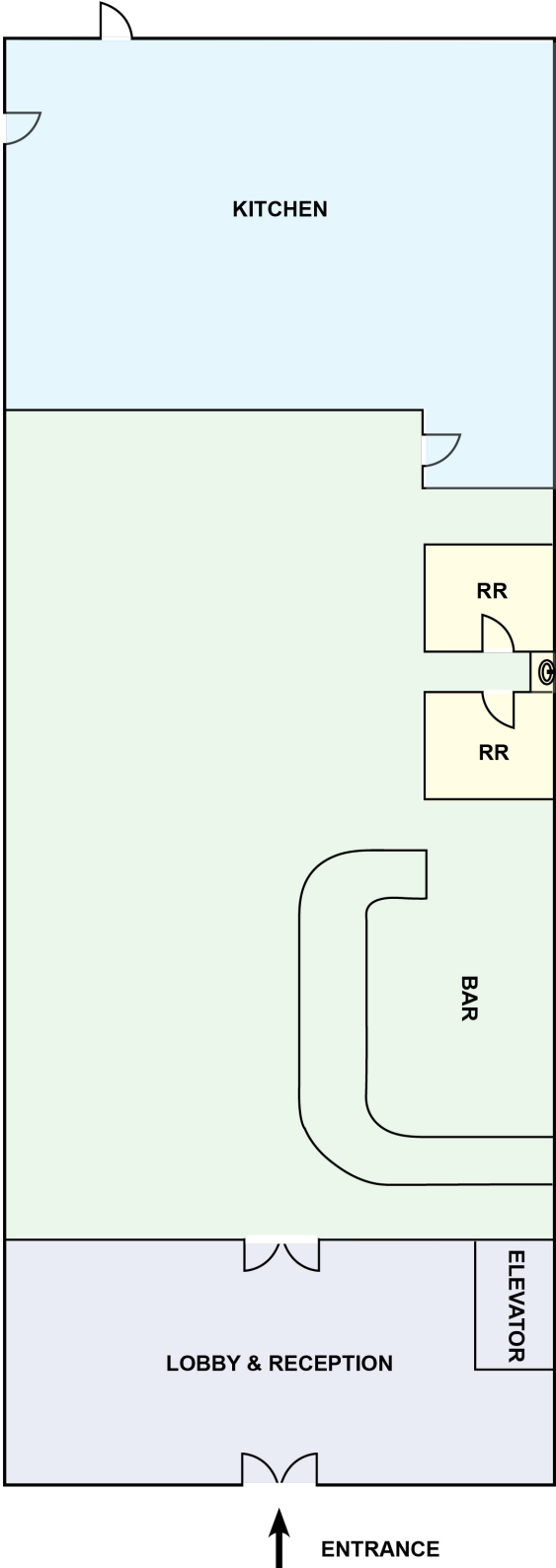

* Floor plan is for illustrative purposes only. All dimensions and layouts are approximate and subject to change.

Unit 2 (Retail) Floor Plan & Photos

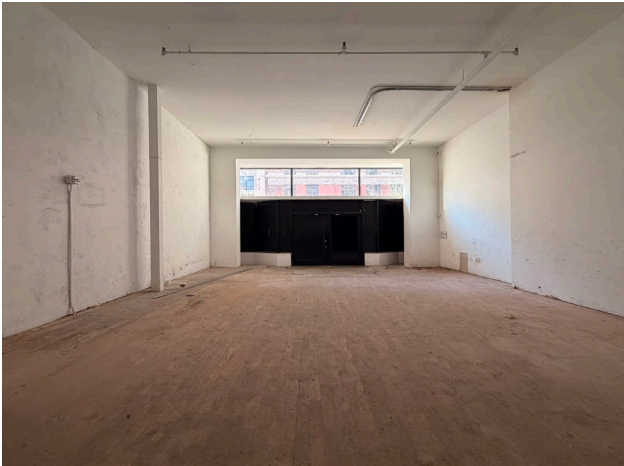
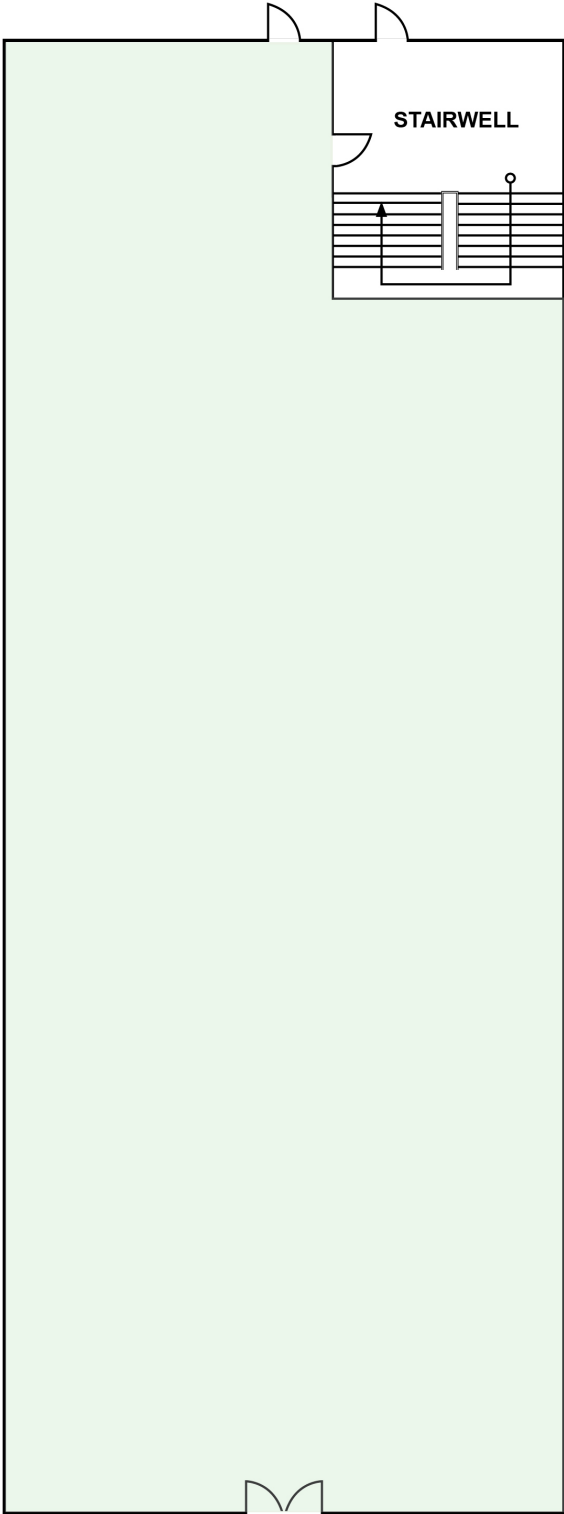

↑ ENTRANCE

** Floor plan is for illustrative purposes only. All dimensions and layouts are approximate and subject to change.*