

FOR LEASE

Move-In Ready Industrial Space

17003-17005 Evergreen Place | City of Industry, CA 91745



±9,000–18,000 SF Move-In Ready Industrial Spaces

17003-17005 Evergreen Place | City of Industry, CA



42,080 SF

Building Size

18,000 SF

Space Available

M

Zoning

Contact Broker

Pricing/Rate

PROPERTY HIGHLIGHTS

	17005B	17005C
Available SF	9,000	9,000
Office SF	1,800	TBD
Clear Height	24'	24'
Grade Level	1	1
Dock High	1	1
Yard	Secured/Fenced	Secured/Fenced
Availability	Vacant	Summer 2026

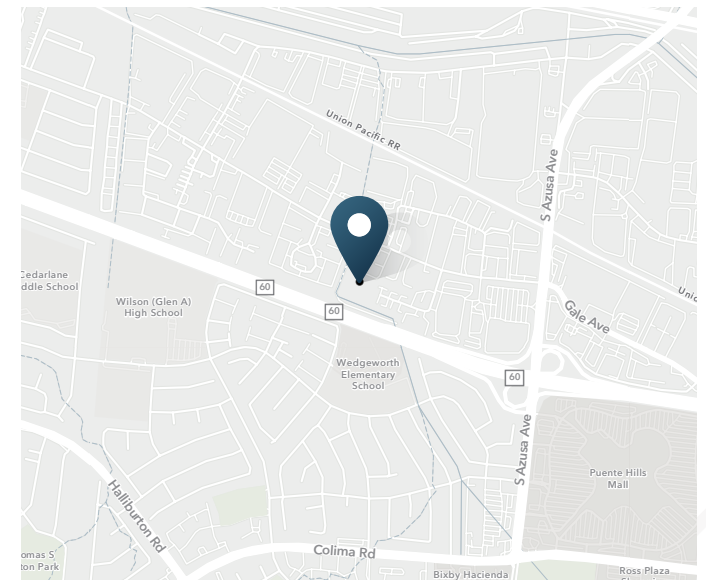

±9,000–18,000 SF Move-In Ready Industrial Spaces

17003-17005 Evergreen Place | City of Industry, CA



±9,000–18,000 SF Move-In Ready Industrial Spaces

17003-17005 Evergreen Place | City of Industry, CA

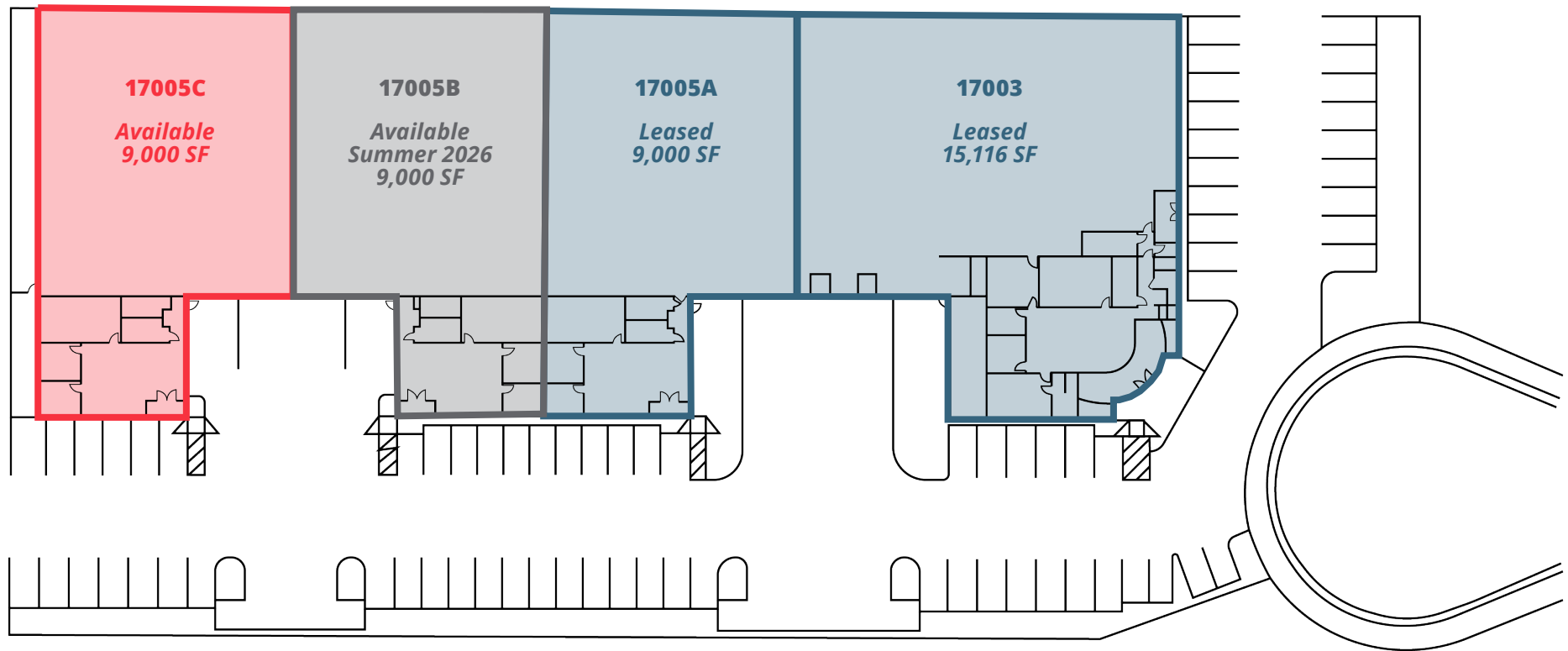

Suite: 17005B

17003-17005 Evergreen Place | City of Industry, CA



Suite: 17005C

17003-17005 Evergreen Place | City of Industry, CA



±9,000–18,000 SF Move-In Ready Industrial Spaces

17003-17005 Evergreen Place | City of Industry, CA

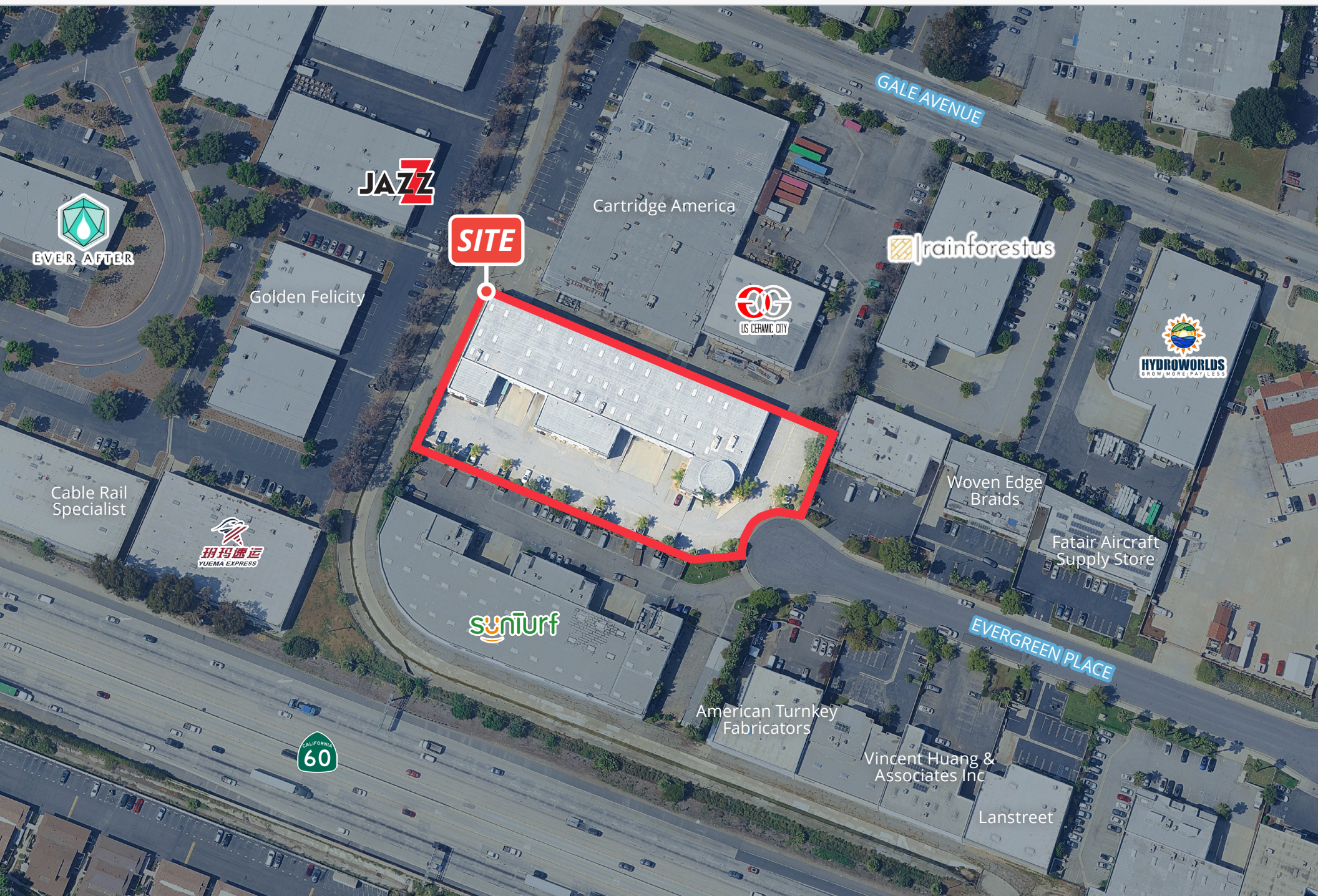

Golden Felicity



Cartridge America



Cable Rail Specialist



Woven Edge Braids

Fatair Aircraft Supply Store

American Turnkey Fabricators

Vincent Huang & Associates Inc

Lanstreet





SRS Real Estate Partners
680 Newport Center Dr., Suite 210
Newport Beach, CA 92660
949.698.1100

Richard Schwartz

EVP & Sr. Managing Principal
714.943.1609
richard.schwartz@srsre.com
CA License No. 01712680

Joey Reaume

EVP & Principal
626.825.2173
joey.reaume@srsre.com
CA License No. 01918579

Nick Moscicki

Vice President
818.606.1632
nick.moscicki@srsre.com
CA License No. 02078491

[SRSRE.COM/Industrial](https://www.srsre.com/Industrial)

© SRS Real Estate Partners

The information presented was obtained from sources deemed reliable;
however SRS Real Estate Partners does not guarantee its completeness or accuracy.