

FOR LEASE

16 & 38 ADRIAN CT

*Two R&D Space Available For
Lease in Burlingame*





With convenient access to public transportation at the Bart/Caltrain Multimodal Station, Adrian Ct is an ideal location for companies with employees commuting from San Francisco, San Jose & the East Bay.

16 Adrian Ct - ±1,606 SF & 38 Adrian Ct - ±1,714 SF

Double door access for shipping & receiving

2.9 miles to SFO

Walking distance to restaurants

US 101 frontage & visibility

\$2.50 NNN

ASKING RATE

\$0.57

OPEX (\$/SF)

HYPOTHETICAL R&D LAB CONVERSION

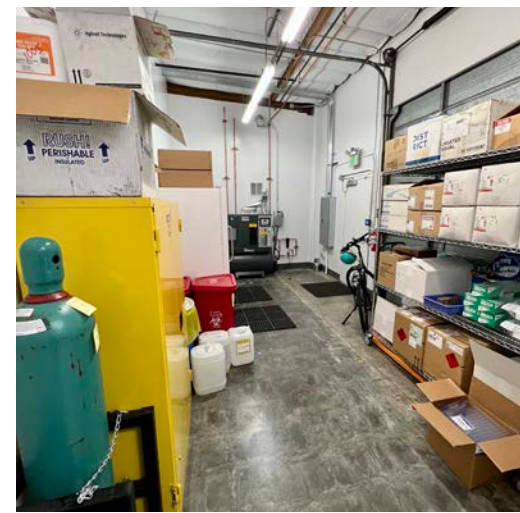
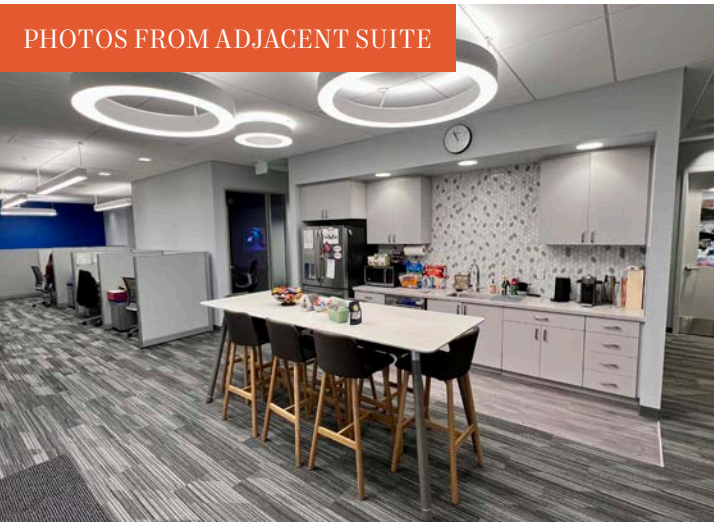

SITE PLAN

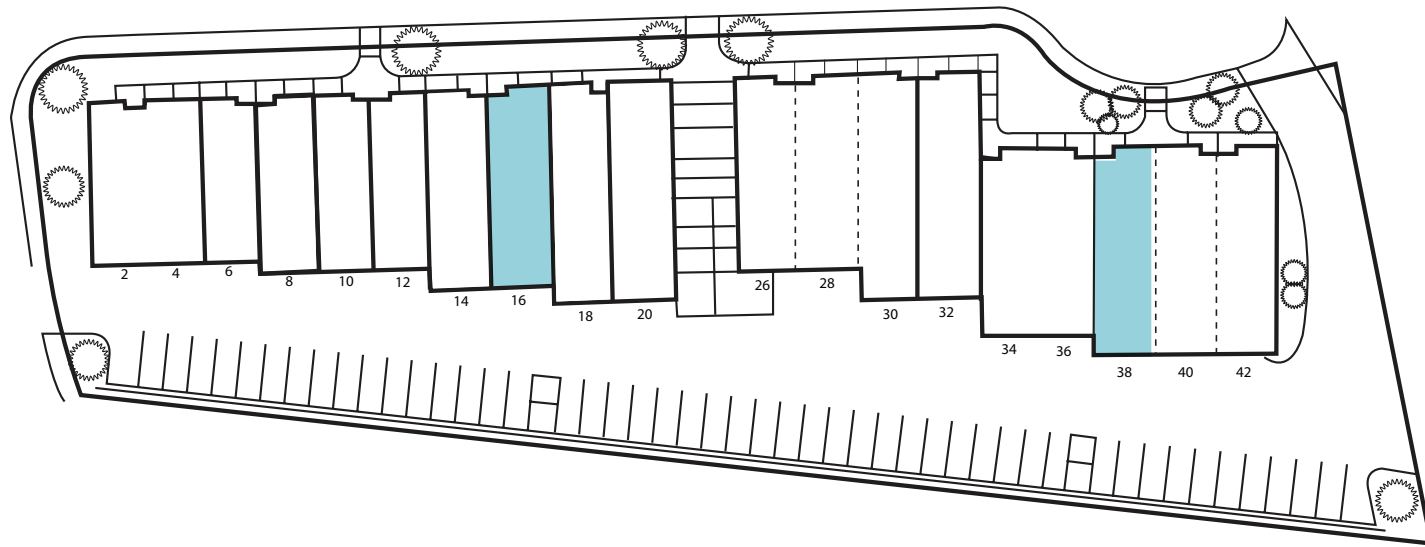

SUITE 16

1,606 SF
AVAILABLE

NOW
AVAILABLE

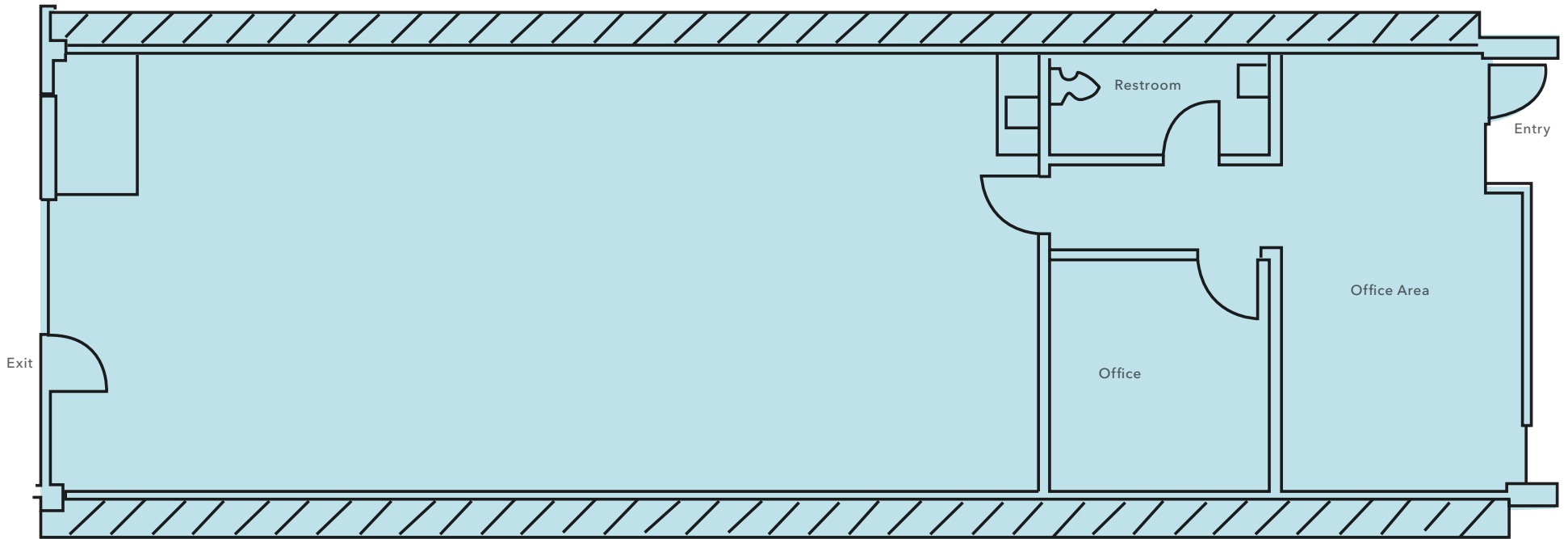

SUITE 38

1,714 SF
AVAILABLE

NOW
AVAILABLE

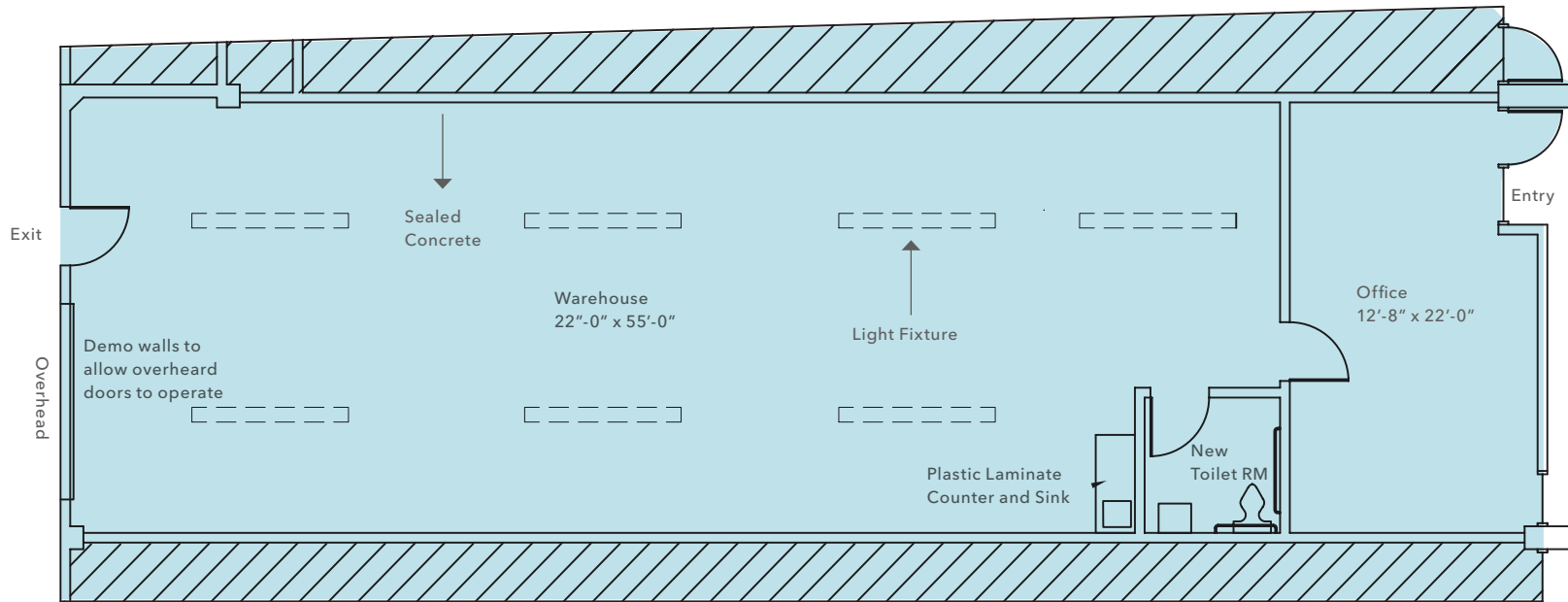

HIGHLY- ACCESSIBLE LOCATION

Easy access to Hwy 101

Walkable to Bart/Caltrain

Minutes to San Francisco Int'l Airport

US 101 frontage & visibility



16 & 42 ADRAIN CT

Exclusively leased by

BRETT WEBER
650.771.3000
brett.weber@kidder.com
LIC N° 01869489

STEVE DIVNEY
650.400.8065
steve.divney@kidder.com
LIC N° 01216239

JOHN MCLELLAN
415.418.9880
john.mclellan@kidder.com
LIC N° 01869489

DREW RAMIREZ
650.430.1433
drew.ramirez@kidder.com
LIC N° 02209477

KIDDER.COM

This information supplied herein is from sources we deem reliable. It is provided without any representation, warranty, or guarantee, expressed or implied as to its accuracy. Prospective Buyer or Tenant should conduct an independent investigation and verification of all matters deemed to be material, including, but not limited to, statements of income and expenses. Consult your attorney, accountant, or other professional advisor.

