

PROPOSED FLOOR PLAN

SCALE: 1/8" = 1'-0"

LEGEND:

- Existing Wall to Remain
- New Full-Height Partition
- New Partial-Height Partition

KEY NOTES:

- 1 Sliding Barn Doors, typ.:
Door - 10 (5 sets) @ 3'-0" x 7'-0" x 2" solid wood
Frame - gwb wrap
Hardware - Barn door track and rollers, satin chrome
- 2 Existing windows to remain throughout; paint. Replace with white blinds as required.
- 3 Existing column enclosed in gwb to remain. Repair enclosure from removal of interior partitions as required to create a smooth, complete enclosure; paint.
- 4 New kitchenette to comply with building standards.
- 5 New partial-height gwb wall with single-pane glass in painted wood frames above, typ. between work stations as indicated on plan (three (3) total); see enlarged elevation for additional info.
- 6 New closet with painted wood shelf, 12" deep with continuous ledger painted to match wall color; chrome rod (split for HCP accessibility), typ.
- 7 New 5/8" gwb on 2x4 metal studs with sound attenuation batt insulation, typ.
- 8 Suite Interior Door:
Door - 2 @ 3'-0" x 6'-8" x 1-3/4" solid core, painted
Frame - Painted wood frame and trim
Hardware - Commercial grade lever handle, satin chrome
- 9 Suite Entry Door:
** see enlarged door elevation **
- 10 Ceilings: Remove existing ACT and drop-in light fixtures. Remove loose plaster from existing beams. Provide new 5/8" gwb wrap tight along ceiling and around beams, typ. Sprinkler lines to remain exposed.
- 11 Lighting: Provide one (1) switch per room; no dimmers or occupancy sensors. 3-way switching provided where necessary. Emergency lighting and exit signs shall be provided according to code and in accordance with ADA Standard Guidelines throughout Tenant space.
General - New indirect suspended linear fluorescent fixture (nine (9) total).
Entry - New decorative pendant fixture (one (1)).
Call Room - New decorative pendant fixture (one (1) in each room).
- 12 Flooring: Remove carpet and carpet glue. Remove/ grind extraneous concrete at entry and patch areas of concrete as required to create a smooth "finished" floor. Apply a polyurethane finish over entire floor.
- 13 Wall Base: painted wood sanitary wall base
- 14 Entry hall signage provided by Landlord, includes business name and suite number; business name also included in directory in Main Lobby.

GENERAL NOTES:

- All items, such as desks, counters and shelving shown on plan shall be assumed to be furniture by the Tenant, unless otherwise specifically indicated on plan.
- Repair all existing walls and ceilings to remain, where damaged by demolition or other construction work, and prepare to receive specified finish.
- Close, fill, or stop all openings in floors, ceilings or other rated assemblies. Prepare retained units for reuse to restored/ refinished and operational condition and preserve during construction operations. Render retained devices operational and refit to match new devices operational and refit to match new devices. Close openings at abandoned devices and prepare smooth to receive new finish.
- Key all locks to building master key system and provide two (2) copies of all keys to Landlord. All openings and hardware shall comply with ADA Design Guidelines.
- Electrical: All devices shall be white with white plastic plates. Landlord to provide receptacles in quantity as indicated below:
At each Office 1x duplex at each work station
At each column n/a
At Conference Room 3x duplex
At Kitchenette Unit 1x microwave outlet, 1x refrigerator outlet
At IT/Server Location 1x Quad and 4x4 plywood panel for computer server
At Call Rooms 1x duplex in each room
Additional Outlets provide outlets throughout space per code
- Data and Communications: Cabling and Equipment shall be by the Tenant. Landlord to provide cable trays for proposed wiring; coordinate locations with Tenant.

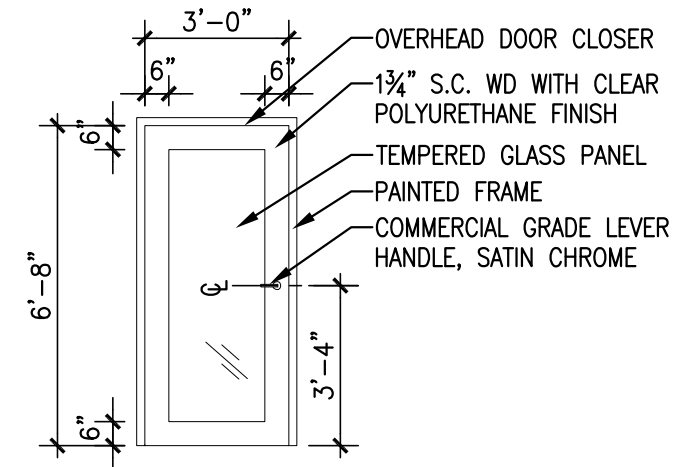

ENLARGED ENTRY DOOR ELEVATION

SCALE: 1/4" = 1'-0"

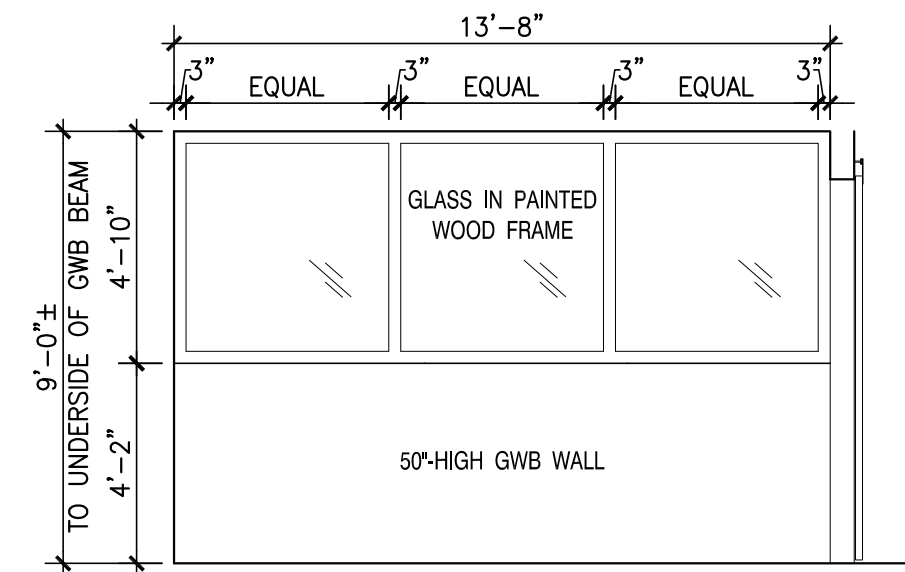

ENLARGED TYPICAL OFFICE WALL ELEVATION

SCALE: 1/4" = 1'-0"